

# M E T R U M

---

## TECHNICAL MANUAL

### RSS-48b

#### AUTOMATED TAPE LIBRARY

- Introduction
- Installation
- Operation
- Principles of Operation
- Service
- Illustrated Parts Breakdown
- Packaging
- Diagrams

#### NOTICE

This technical manual is prepared in accordance with standards of good commercial practice. It is not intended in whole or in part to satisfy specific requirements of military or government specifications. Preparation of contents to such specifications will be quoted on request.

---

METRUM, Inc.  
Peripheral Products  
P.O. Box 5227  
Denver, CO 80217-5227

16828600-001B  
August 1993  
Printed in U.S.A.



## **ESDS DEVICE HANDLING**

### **CAUTION**

This unit contains devices subject to damage from electrostatic discharge (ESD). Handle electrostatic discharge sensitive (ESDS) devices in accordance with the following precautions and instructions. Refer to DOD-HDBK-263 and DOD-STD-1686 for additional ESD information.

1. ESDS components and circuit cards are shipped in special static dissipative shipping containers. Ensure that all required precautions are taken before opening the containers. Retain the containers for use when shipping ESD components. All static dissipative containers are identified with a warning label alerting the handler that the contents are ESD sensitive.
2. Because most Metrum circuit cards contain ESDS components, all circuit cards should be treated as being ESD sensitive. Individual components are not generally identified as being ESDS, except in packaging.
3. ESDS components should only be handled under the following conditions:
  - a. **WHEN HANDLING ESDS ASSEMBLIES OR DEVICES, THE HANDLER MUST WEAR A STATIC CONTROL WRIST STRAP CONNECTED TO HIS OR HER SKIN.**

The wrist strap must then be connected, through a 1 megohm resistor, to a static dissipative table top or to the equipment chassis ground. (NOTE: Most wrist straps have the 1 megohm resistor built in.) The static dissipative table top must be connected to ground through a 1 megohm resistor.
  - b. Handle ESDS components by the case or body whenever possible, and minimize touching of the leads.
  - c. Avoid the use of air blasts or aerosol sprays on ESDS circuit cards or components.
  - d. Pack and unpack ESDS components and devices only in static-free environments on a static dissipative table top. The handler must wear a wrist strap during packing or unpacking.

- e. Keep all common plastics and clothing away from ESDS devices.
  - f. All soldering irons, test equipment, and equipment chassis must be grounded. Grounded power cords must be plugged in, even if the equipment is turned off.
  - g. Solder suckers must be of the antistatic type.
  - h. Brushes must be of natural bristle.
4. Ensure that all ESDS devices are properly packaged in static dissipative coverings when in storage or transit.

# **WARNINGS AND SAFETY**

---

## **FEDERAL COMMUNICATION COMMISSION (FCC)**

### **WARNING**

**This equipment generates, uses, and can radiate radio frequency energy and if not installed and used in accordance with the Instruction Manual, may cause interference to radio communications. It has been tested and found to comply with the limits for a class A computing device pursuant to Subpart J of Part 15 of FCC rules, which are designed to provide reasonable protection against such interference when operated in a commercial environment. Operation of this equipment is likely to cause interference in which case the user at his own expense will be required to take whatever measures may be required to correct the interference.**

## **DEPARTMENT OF COMMUNICATIONS (DOC)**

### **WARNING**

**This digital apparatus does not exceed the Class A limits for radio noise emissions from digital apparatus as set out in the interference-causing equipment standard entitled "Digital Apparatus", ICES-003 of the Canadian Department of Communications.**

### **AVERTISSEMENT**

**Cet appareil numérique respecte les limites de bruits radioélectriques applicables aux appareils numériques de Classe A prescrites dans la norme sur le matériel brouilleur: "Appareils Numériques", NMB-003 éditée par le ministre des Communications de Canada.**

### **CAUTION**

**Failure to comply with the installation instructions found in paragraph 2.7.4.2 will void emission compliance.**

# VERBAND DEUTSCHER ELEKROTECHNIKER (VDE)

Anhang zur Anlango 1 zur AmtabIVtg 243/1991

Bescheinigung des  
Herstellers/Importeurs

Hiermit wird bescheinigt, daß die

SYSTEM, ROBOTIC INFORMATION STORAGE RSS-48b

(Gerät, Typ, Bezeichnung)

DIN-VDE-Norm bzw, EN-Norm Bzw, BMPT-AmtabIVtg 243/1991 funk-entstört ist.  
Dem Bundesamt für Zulassungen in der Telekommunikation wurde das Inverkehrbringen  
dieses Gerätes angezeigt und die Berechtigung zur Überprüfung der Serie auf die  
Einhaltung der Bestimmungen eingeräumt.

METRUM, Inc.  
4800 EAST DRY CREEK ROAD  
LITTLETON, COLORADO 80122  
USA

ASACA CORPORATION  
3-4-28 ASAHIGAOKA  
HINO CITY, TOKYO 191  
JAPAN

# SAFETY SYMBOLS

---

The following international marking symbols are used in the RSS-48b Rotary Storage System. Their meanings are as follows:



DANGEROUS VOLTAGE



PROTECTIVE EARTH (GROUND) CONDUCTOR TERMINAL. FOR PROTECTION AGAINST ELECTRICAL SHOCK IN CASE OF A FAULT.



ATTENTION: OPERATOR MUST REFER TO FURTHER EXPLANATIONS IN THE OPERATING INSTRUCTIONS.



ALTERNATING CURRENT (POWER LINE)



OFF (POWER: DISCONNECTED TO THE MAINS)



ON (POWER: CONNECTION TO THE MAINS)



STANDBY (PARTIAL DISCONNECTION FROM POWER MAINS. MAINS ARE CONNECTED TO PRIMARY CIRCUITS ONLY)



# TABLE OF CONTENTS

Page

## SECTION 1-INTRODUCTION

1.1	GENERAL .....	1-1
1.2	SPECIFICATIONS .....	1-2
1.3	DESCRIPTION .....	1-2
1.3.1.	FUNCTIONAL DESCRIPTION .....	1-2
1.3.2.	TAPE DRIVES .....	1-2
1.4.	ACCESSORIES SUPPLIED .....	1-3
1.5.	ACCESSORIES AVAILABLE .....	1-4
1.6.	OPTIONS .....	1-4
1.7.	IDENTIFICATION .....	1-4
1.8.	CONFIGURATION .....	1-5
1.9.	WARRANTY .....	1-5

## SECTION 2-INSTALLATION

2.1.	GENERAL .....	2-1
2.2.	SAFETY PRECAUTIONS .....	2-2
2.2.1.	ELECTRICAL SAFETY .....	2-2
2.2.2.	MECHANICAL SAFETY .....	2-3
2.3.	EQUIPMENT REQUIRED .....	2-4
2.4.	SITE REQUIREMENTS .....	2-4
2.4.1.	PHYSICAL REQUIREMENTS .....	2-4
2.4.2.	POWER REQUIREMENTS .....	2-6
2.4.3.	ENVIRONMENTAL REQUIREMENTS .....	2-6
2.4.4.	SAFETY REQUIREMENTS .....	2-7
2.5.	UNPACKING .....	2-8
2.6.	PLACING/LEVELING .....	2-11
2.7.	INSTALLATION .....	2-12
2.7.1.	SHIPPING BRACKETS .....	2-13
2.7.2.	POWER CONNECTION .....	2-17
2.7.2.1.	Facility Power .....	2-17
2.7.2.2.	Line Voltage Setting .....	2-17
2.7.2.3.	Power Cable .....	2-19
2.7.2.	STROMANSCHLUSS .....	2-17
2.7.2.1.	Anlagenspannung .....	2-17
2.7.2.2.	Netzspannungseinstellung .....	2-17
2.7.2.3.	Netzkabel .....	2-19
2.7.2.	ALIMENTATION DU RSS-48B .....	2-17
2.7.2.1.	Réseau d'alimentation .....	2-17
2.7.2.2.	Réglage de la tension de ligne .....	2-17
2.7.2.3.	Câble d'alimentation .....	2-19
2.7.3.	DRIVE INSTALLATION .....	2-21
2.7.3.1.	RSP-2150 AND VLDS .....	2-21
2.7.4.	COMMUNICATION .....	2-25
2.7.4.1.	Interconnect Cable .....	2-25
2.7.4.2.	RS-232C Cable Connection .....	2-26
2.7.4.3.	Communication Parameters .....	2-26
2.7.4.4.	Serial Interface Signals .....	2-28
2.7.5.	ALARMS .....	2-28

## TABLE OF CONTENTS (Cont.)

Page

### SECTION 2-INSTALLATION - Continued

2.8.	INITIAL TURN-ON .....	2-29
2.8.1.	INITIAL POWER-UP .....	2-29
2.8.2.	OPERATIONAL CHECK AND ADJUSTMENT .....	2-31
2.9.	INSTALLATION TROUBLESHOOTING .....	2-35

### SECTION 3-OPERATION

3.1.	GENERAL .....	3-1
3.2.	RSS-48b FRONT AND REAR PANEL FEATURES .....	3-1
3.2.1.	OPERATIONAL PANEL .....	3-5
3.3.	TAPE DRIVE FEATURES .....	3-6
3.4.	DATA CARTRIDGES .....	3-6
3.4.1.	BAR CODE LABEL .....	3-6
3.4.2.	LOADING DATA CARTRIDGES .....	3-8
3.4.3.	UNLOADING DATA CARTRIDGES .....	3-9
3.4.4.	DATA CARTRIDGES HANDLING .....	3-10
3.5.	LOCAL OPERATING PROCEDURES .....	3-12
3.5.1.	POWER-UP .....	3-12
3.5.2.	OPERATION .....	3-12
3.5.3.	POWER DOWN .....	3-12
3.6.	REMOTE OPERATION PROCEDURES .....	3-14
3.6.1.	POWER-UP .....	3-14
3.6.2.	OPERATION .....	3-14
3.6.3.	POWER DOWN .....	3-14
3.7.	COMMANDS .....	3-15
3.7.1.	ALARM CLEAR COMMAND .....	3-16
3.7.2.	ALARM ON COMMAND .....	3-17
3.7.3.	BAR CODE READ COMMAND 1 .....	3-18
3.7.4.	BAR CODE READ COMMAND 2 .....	3-19
3.7.5.	CARTRIDGE CARRYING COMMAND 1 .....	3-20
3.7.6.	CARTRIDGE CARRYING COMMAND 2 .....	3-21
3.7.7.	CARTRIDGE HANDLER MOVE COMMAND .....	3-22
3.7.8.	CARTRIDGE LOAD COMMAND 1 .....	3-23
3.7.9.	CARTRIDGE LOAD COMMAND 2 .....	3-24
3.7.10.	CARTRIDGE STORE COMMAND 1 .....	3-25
3.7.11.	CARTRIDGE STORE COM MAND 2 .....	3-26
3.7.12.	DISPLAY COMMAND .....	3-27
3.7.13.	DOOR SENSOR/CARRIER CARTRIDGE SENSE COMMAND .....	3-28
3.7.14.	DRUM SET COMMAND .....	3-29
3.7.15.	EJECT COMMAND .....	3-30
3.7.16.	INJECT COMMAND .....	3-31
3.7.17.	MANUAL OPERATION ENABLE COMMAND .....	3-32
3.7.18.	RESET COMMAND .....	3-33
3.7.19.	COMMAND SUMMARY .....	3-34
3.7.20.	RESPONSE SUMMARY .....	3-35
3.7.21.	FRONT DOOR INTERRUPT .....	3-36
3.7.22.	ERROR CODES .....	3-37

## TABLE OF CONTENTS (Cont.)

Page

### SECTION 3-OPERATION – Continued

3.8.	MAINTENANCE .....	3-38
3.8.1.	OPERATOR'S PREVENTIVE MAINTENANCE .....	3-38
3.8.1.1.	Materials Required .....	3-38

### SECTION 4-PRINCIPLES OF OPERATION

4.1.	GENERAL .....	4-1
4.2.	FUNCTIONAL DESCRIPTION .....	4-1
4.3.	CIRCUIT DESCRIPTION .....	4-3
4.3.1.	CONTROL BLOCK .....	4-3
4.3.1.1.	CPU CCA (Slot #1) .....	4-3
4.3.1.2.	Sensor 1 CCA (Slot #2) .....	4-4
4.3.1.3.	Sensor 2 CCA (Slot #3) .....	4-5
4.3.1.4.	Drive and I/O CCA (Slot #4) .....	4-6
4.3.1.5.	FIP (Fluorescent Indicator Panel) I/O CCA (Slot #7) .....	4-6
4.3.1.6.	Pulse Motor Controller CCA (Slots #8 and #9) .....	4-7
4.3.1.7.	Motherboard CCA .....	4-7
4.3.2.	LOCAL CONTROL BLOCK .....	4-8
4.3.2.1.	Display CCA .....	4-8
4.3.2.2.	Operation Panel Switch CCA .....	4-8
4.3.3.	DRUM BLOCK .....	4-9
4.3.3.1.	Pulse Motor Driver #1 Module .....	4-10
4.3.3.2.	Drum Pulse Motor .....	4-10
4.3.3.3.	Drum Sensors .....	4-11
4.3.4.	ELEVATOR BLOCK .....	4-12
4.3.4.1.	Pulse Motor Driver #2 Module .....	4-13
4.3.4.2.	Elevator Pulse Motor .....	4-13
4.3.4.3.	Elevator Sensor CCA .....	4-13
4.3.5.	HANDLER BLOCK .....	4-14
4.3.5.1.	Z-Motor Circuitry .....	4-15
4.3.5.2.	Position/Detection Circuitry .....	4-15
4.3.5.3.	Bar Code Reader Circuitry .....	4-15
4.3.6.	POWER SUPPLY BLOCK .....	4-16
4.3.6.1.	Power Transformer .....	4-16
4.3.6.2.	Power Supply #1 Module .....	4-16
4.3.6.3.	Power Supply #2 Module .....	4-16
4.3.6.4.	Power Supply #3 Module .....	4-16

### SECTION 5-SERVICE

5.1.	GENERAL .....	5-1
5.2.	SAFETY PRECAUTIONS .....	5-2
5.2.1.	ELECTRICAL SAFETY .....	5-2
5.3.	TOOLS AND TEST EQUIPMENT .....	5-3
5.3.1.	TEST EQUIPMENT .....	5-3
5.3.2.	SPECIAL TOOLS .....	5-3
5.3.3.	COMMON TOOLS .....	5-3
5.4.	PREVENTIVE MAINTENANCE .....	5-3
5.4.1.	SCHEDULED PROCEDURES .....	5-3

## TABLE OF CONTENTS (Cont.)

Page

### SECTION 5-SERVICE – Continued

5.5.	TROUBLESHOOTING .....	5-6
5.5.1.	TROUBLESHOOTING HINTS .....	5-7
5.5.1.1.	CCA LED's .....	5-7
5.5.1.1.1.	CPU CCA (Slot #1) .....	5-7
5.5.1.1.2.	Sensor 1 CCA (Slot #2) .....	5-7
5.5.1.1.3.	Sensor 2 CCA (Slot #3) .....	5-9
5.5.1.1.4.	Drive and I/O CCA (Slot #4) .....	5-9
5.5.1.1.5.	FIP I/O CCA (Slot #7) .....	5-10
5.5.1.1.6.	Pulse Motor Controller CCA (Slots #8 and #9) .....	5-10
5.5.1.1.7.	Drum Gray Code Sensor CCA .....	5-10
5.5.1.1.8.	Bar Code Reader Circuitry .....	5-10
5.5.1.2.	CCA Switches .....	5-10
5.5.1.3.	CCA Jumpers .....	5-11
5.6.	REPAIR AND REPLACEMENT PROCEDURES .....	5-12
5.6.1.	DISASSEMBLY AND ASSEMBLY INSTRUCTIONS .....	5-12
5.6.1.1.	Maintenance Access .....	5-13
5.6.1.2.	Fan .....	5-15
5.6.1.3.	Display Assembly .....	5-15
5.6.1.4.	Operational Panel Assembly .....	5-17
5.6.1.5.	Interlock Switch .....	5-17
5.6.1.6.	Control Cage CCA'S .....	5-18
5.6.1.7.	Power Switches (Circuit Breaker) .....	5-18
5.6.1.8.	Line Filters .....	5-20
5.6.1.9.	Pulse Motor Driver .....	5-21
5.6.1.10.	Power Transformer .....	5-22
5.6.1.11.	Power Supply #1 .....	5-23
5.6.1.12.	Power Supply #2 .....	5-23
5.6.1.13.	Power Supply #3 .....	5-23
5.6.1.14.	Rotary Storage Drum .....	5-25
5.6.1.14.1.	Drum Pulse Motor/Drive Belts .....	5-27
5.6.1.14.2.	Drum Gray Code Sensor CCA .....	5-27
5.6.1.14.3.	Drum Slit Sensor CCA .....	5-29
5.6.1.14.4.	Drum Face Tab .....	5-29
5.6.1.15.	Handler Assembly .....	5-30
5.6.1.15.1.	Rubber Fingers .....	5-31
5.6.1.15.2.	Plate Springs .....	5-31
5.6.1.15.3.	Coil Springs .....	5-32
5.6.1.15.4.	Cartridge Sensor Switch .....	5-32
5.6.1.15.5.	Cartridge Sensor Switch Spring .....	5-32
5.6.1.15.6.	Z-Motor .....	5-33
5.6.1.15.7.	Handler Drive Belt .....	5-34
5.6.1.16.	Elevator Assembly .....	5-35
5.6.1.16.1.	Elevator Gray Code Sensor CCA .....	5-37
5.6.1.16.2.	50-Pin Cable Assembly .....	5-37
5.6.1.16.3.	Elevator Motor Assembly .....	5-39
5.6.1.16.4.	Inner Drive Belt .....	5-40
5.6.1.16.5.	Outer Drive Belt .....	5-42
5.6.1.16.6.	A and B Guide Rollers .....	5-44

## TABLE OF CONTENTS (Cont.)

Page

### SECTION 5-SERVICE – Continued

5.6.2.	REPAIR .....	5-46
5.6.2.1.	Limited Repair .....	5-46
5.6.2.2.	Repair Parts .....	5-46
5.6.2.3.	Repair/Exchange Program .....	5-46
5.6.2.4.	Post Repair Adjustments .....	5-46
5.7.	ADJUSTMENTS .....	5-47
5.7.1.	PULSE MOTOR .....	5-48
5.7.2.	Z-MOTOR .....	5-50
5.7.3.	BAR CODE .....	5-52
5.7.3.1.	CCD Camera Lens .....	5-53
5.7.3.2.	Bar Code DC Level .....	5-54
5.7.3.3.	Bar Code Gain .....	5-54
5.7.3.4.	Slice Level .....	5-55
5.7.3.5.	Blanking Width .....	5-56
5.7.4.	DRUM ROTATION STOP .....	5-57
5.7.5.	ELEVATOR HORIZONTAL AND HEIGHT .....	5-57
5.7.5.1.	Horizontal Position .....	5-57
5.7.5.2.	Height Position .....	5-58

### SECTION 6-ILLUSTRATED PARTS BREAKDOWN

6.1.	GENERAL .....	6-1
6.1.1.	FIGURE NUMBER .....	6-1
6.1.2.	INDEX NUMBER .....	6-1
6.1.3.	MANUFACTURER'S PART NUMBER .....	6-1
6.1.4.	DESCRIPTION .....	6-1
6.1.4.1.	Indenture .....	6-2
6.1.4.2.	Reference Designator .....	6-2
6.1.4.3.	CAGE Code .....	6-2
6.1.4.4.	Cross-Reference Notes .....	6-2
6.1.5.	QUANTITY PER ASSEMBLY .....	6-3
6.1.6.	NOTES .....	6-3
6.2.	RECOMMENDED SPARE PARTS LIST .....	6-3
6.3.	ORDERING INFORMATION .....	6-4
6.4.	PARTS LIST AND ILLUSTRATIONS .....	6-4
6.5.	MANUFACTURERS .....	6-4
6.6.	ASSEMBLY INTERCHANGEABILITY LIST .....	6-5
6.7.	RECOMMENDED LEVEL OF MAINTENANCE .....	6-6

## TABLE OF CONTENTS (Cont.)

Page

### SECTION 7-PACKAGING

7.1.	GENERAL .....	7-1
7.2.	SAFETY PRECAUTIONS .....	7-1
7.2.1.	ELECTRICAL SAFETY .....	7-1
7.2.2.	MECHANICAL SAFETY .....	7-2
7.3.	EQUIPMENT REQUIRED .....	7-3
7.4.	PACKAGING .....	7-3
7.4.1.	DISASSEMBLY .....	7-3
7.4.1.1.	Power Cable Removal .....	7-3
7.4.1.2.	RS-232C Cable Removal .....	7-3
7.4.1.3.	Alarm Cable Removal .....	7-4
7.4.1.4.	Drive Removal .....	7-4
7.4.1.5.	Preparation for Shipment .....	7-4
7.4.2.	PACKING .....	7-7

## LIST OF ILLUSTRATIONS

		Page
Figure 1-1	RSS-48b Functional Diagram .....	1-3
Figure 2-1	RSS-48b Outline Dimensions .....	2-5
Figure 2-2	RSS-48b Unpacking .....	2-9
Figure 2-3	RSS-48b Placing and Leveling .....	2-12
Figure 2-4	RSS-48b Shipping Brackets .....	2-14
Figure 2-5	RSS-48b Voltage Selection and Power Connection .....	2-18
Abbildung 2-5	RSS-48b Spannungswahl und Stromanschluss .....	2-18
Figure 2-5	Sélection de la tension et alimentation du RSS-48b .....	2-18
Figure 2-6	RSS-48b Power Input Block (TB1) .....	2-19
Abbildung 2-6	RSS-48b Stromeingang .....	2-19
Figure 2-6	Arrivée de courant du RSS-48b .....	2-19
Figure 2-7	Power Cable Wall Plug Standards .....	2-20
Abbildung 2-7	Netzkabelstecker-Normen .....	2-20
Figure 2-7	Types de fiches de câbles d'alimentation .....	2-20
Figure 2-8	Tape Drive Installation .....	2-23
Figure 2-9	RSS-48b Communication Parameters .....	2-24
Figure 2-10	Interconnect Cable .....	2-25
Figure 2-11	Serial Data Format .....	2-26
Figure 2-12	RSS-48b Initial Turn-on .....	2-30
Figure 2-13	RSS-48b Initial Check and Adjustments .....	2-32
Figure 3-1	RSS-48b Front and Rear Panel Features .....	3-2
Figure 3-2	RSS-48b Operational Panel Features .....	3-5
Figure 3-3	Bar Code Label and Data Cartridge Loading .....	3-7
Figure 3-4	RSS-48b Data Cartridge .....	3-11
Figure 3-5	Local Operation .....	3-13
Figure 3-6	RSS-48b Operator's Preventive Maintenance .....	3-40
Figure 4-1	RSS-48b Simplified Functional Diagram .....	4-2
Figure 4-2	Drum Motor .....	4-9
Figure 4-3	Pulse Motor Operation .....	4-10
Figure 4-4	Drum Sensors Operation .....	4-11
Figure 4-5	Elevator Operation .....	4-12
Figure 4-6	Elevator Sensor Operation .....	4-13
Figure 4-7	Handler Components .....	4-14
Figure 4-8	Bar Code Read Operation .....	4-15
Figure 5-1	Preventive Maintenance .....	5-5
Figure 5-2	RSS-48b Assembly Locator Diagram .....	5-12
Figure 5-3	RSS-48b Maintenance Access .....	5-14
Figure 5-4	Fan, Display, Operational Panel, and Interlock Switch Replacement .....	5-16
Figure 5-5	Control Cage CCA, Circuit Breaker, and Power Connector Replacement .....	5-19
Figure 5-6	Line Filter Replacement .....	5-20
Figure 5-7	Pulse Motor Driver Replacement .....	5-21
Figure 5-8	Power Transformer Replacement .....	5-22
Figure 5-9	Power Supply Replacement .....	5-24
Figure 5-10	Rotary Storage Drum Assembly Replacement .....	5-26
Figure 5-11	Drum Motor, Drive Belt, Sensor CCA, and Tab Replacement .....	5-28
Figure 5-12	Handler Assembly Replacement .....	5-30
Figure 5-13	Handler Finger, Spring, and Switch Replacement .....	5-31
Figure 5-14	Handler Z-Motor and Drive Belt Replacement .....	5-33
Figure 5-15	Elevator (Cartridge Loader) Assembly Replacement .....	5-36

## LIST OF ILLUSTRATIONS – Continued

		Page
Figure 5-16	Elevator Sensor CCA and 50-Pin Cable Replacement .....	5-38
Figure 5-17	Elevator Motor Replacement .....	5-39
Figure 5-18	Inner Elevator Drive Belt Replacement .....	5-41
Figure 5-19	Outer Elevator Drive Belt Replacement .....	5-43
Figure 5-20	A and B Guide Roller Replacement .....	5-45
Figure 5-21	Handler Cover .....	5-50
Figure 5-22	Lens Focusing .....	5-53
Figure 5-23	DC Level .....	5-54
Figure 5-24	Gain .....	5-55
Figure 5-25	Slice Level .....	5-56
Figure 5-26	Blanking Width .....	5-56
Figure 5-27	Drum and Elevator Adjustments .....	5-59
Figure 6-1	Rotary Storage RSS-48b (Sheet 1 of 2) .....	6-8
Figure 6-1	Rotary Storage RSS-48b (Sheet 2 of 2) .....	6-9
Figure 6-2	Handler Assembly .....	6-10
Figure 6-3	Elevator Assembly .....	6-11
Figure 6-4	Front Door Assembly .....	6-12
Figure 6-5	Drum Assembly .....	6-13
Figure 7-1	Preparation for Shipment .....	7-5
Figure 7-2	Shipping Crate .....	7-8
Figure 7-3	Wrapping the RSS-48b .....	7-8
Figure 7-4	RSS-48b Packing .....	7-11
Figure 8-1	RSS-48b Functional Block Diagram .....	8-3
Figure 8-2	Power Interconnect Diagram (Sheet 1 of 2) .....	8-5
Figure 8-2	Power Interconnect Diagram (Sheet 2 of 2) .....	8-7
Figure 8-3	Interconnection Diagram (Sheet 1 of 4) .....	8-9
Figure 8-3	Interconnection Diagram (Sheet 2 of 4) .....	8-11
Figure 8-3	Interconnection Diagram (Sheet 3 of 4) .....	8-13
Figure 8-3	Interconnection Diagram (Sheet 4 of 4) .....	8-15
Figure 8-4	Motherboard CCA Interconnect Diagram (Sheet 1 of 2) .....	8-17
Figure 8-4	Motherboard CCA Interconnect Diagram (Sheet 2 of 2) .....	8-19
Figure 8-5	RSS-48b Led, Switch, and Jumpers Diagram (Sheet 1 of 2) .....	8-21
Figure 8-5	RSS-48b Led, Switch, and Jumpers Diagram (Sheet 2 of 2) .....	8-23
Figure 8-6	AC Power Problems and No Initialization Troubleshooting Tree .....	8-25
Figure 8-7	Display and Operational Panel Problems Troubleshooting Tree .....	8-27
Figure 8-8	Communication Problems Troubleshooting Tree .....	8-29
Figure 8-9	Error OG2> Troubleshooting Tree (Sheet 1 of 2) .....	8-31
Figure 8-9	Error OG2> Troubleshooting Tree (Sheet 2 of 2) .....	8-33
Figure 8-10	Error OG3> Troubleshooting Tree (Sheet 1 of 3) .....	8-35
Figure 8-10	Error OG3> Troubleshooting Tree (Sheet 2 of 3) .....	8-37
Figure 8-10	Error OG3> Troubleshooting Tree (Sheet 3 of 3) .....	8-39
Figure 8-11	Error OG5> Troubleshooting Tree .....	8-41
Figure 8-12	Error ON1> and ON2> Troubleshooting Tree .....	8-43

## LIST OF TABLES

	Page
Table 1-1	Reference Designators ..... 1-3
Table 2-1	Required Equipment ..... 2-4
Table 3-1	Command Summary ..... 3-34
Table 3-2	Response Summary ..... 3-35
Table 3-3	Error Codes..... 3-37
Table 3-4	Preventive Maintenance Procedures..... 3-39
Table 5-1	Required Equipment ..... 5-3
Table 5-2	Preventive Maintenance Procedures ..... 5-4
Table 5-3	RSS-48b Troubleshooting ..... 5-8
Table 5-4	Error Message Troubleshooting ..... 5-8
Table 5-5	Post-Repair Adjustments ..... 5-47
Table 6-1	Operator's Level Recommended Spare Parts List ..... 6-3
Table 6-2	Bench Level Recommended Spare Parts List (1 of 2) ..... 6-3
Table 6-3	RSS-48b Rotary Storage Subsystem ..... 6-14
Table 7-1	Required Equipment ..... 7-3



# 1. INTRODUCTION

---

## 1.1. GENERAL

This technical manual provides operating and maintenance instructions for the RSS-48b Automatic Tape Library. Throughout this manual, the RSS-48b Automatic Tape Library will be referred to as the RSS-48b.

This manual is arranged into eight sections as follows:

**NOTE** This manual contains the information required to repair the RSS-48b only to the lowest field replaceable unit, as determined by the manufacturer. This repair philosophy is basically a module exchange, with some individual high-wear parts included.

- **Section 1 — Introduction:** Provides an overview of this manual and contains RSS-48b specifications.
- **Section 2 — Installation:** Describes how to unpack and prepare the RSS-48b for use (both local and remote operation).
- **Section 3 — Operation:** Describes the front and rear panel features, and operator's level maintenance instructions. Also provided is detailed information on all the commands used during remote operation of the RSS-48b over the RS-232C serial interface.
- **Section 4 — Principles of Operation:** Describes how the RSS-48b's internal modules, assemblies and subassemblies operate.
- **Section 5 — Service:** Provides the information required to perform preventive maintenance, fault isolate to the defective field replaceable part, remove and replace defective parts, and perform any post repair adjustments.

### CAUTION

This equipment contains ESDS devices. Proper ESDS device handling procedures must be followed. Refer to the ESDS DEVICE HANDLING information at front of this manual.

**NOTE** A RSS-48b service training program is available upon request. This course is strongly recommended prior to servicing the RSS-48b, as maintaining enforcement of the product warranty requires that all maintenance and service procedures be performed by trained service personnel. Contact your Distributor for more information.

- **Section 6 — Parts List:** Lists and illustrates all field replaceable parts.
- **Section 7 — Packaging:** Describes how to repackage the RSS-48b for storage or shipment.
- **Section 8 — Diagrams:** Contains the fold-out diagrams required to maintain the RSS-48b.

## 1.2. SPECIFICATIONS

Specifications for the RSS-48b are provided in the Product Information Sheet, which is included in the back of this section. These specifications are the performance standards to which the RSS-48b is expected to perform.

## 1.3. DESCRIPTION

The RSS-48b is an automatic, random access, tape library system that is specifically designed to accommodate Metrum Tape Drives (supplied separately). The combination of the RSS-48b's high performance robotics, and Metrum's helical-scan technology tape drives, provides a tape library system capable of storing over 500 gigabytes (0.5 terabytes) of data. Actual storage capacity is dependent on the tape drive(s) model installed and the type of data cartridge used.

Data is stored on up to 48 one-half inch data cartridges, each uniquely identified using a bar code. Using Y/Z robotics and a rotating storage drum, the RSS-48b is capable of retrieving a specific data cartridge in less than 8 seconds. Once retrieved, the data cartridge can be moved to a specified tape drive, or loaded into a different bin in the storage drum.

The RSS-48b can be operated locally using the front panel, or remotely with an internal or external host computer (not supplied) via the RS-232C serial interface using commands.

### 1.3.1. FUNCTIONAL DESCRIPTION

Basically, the RSS-48b is comprised of four functional blocks (refer to Figure 1-1).

- Rotary Storage Drum – stores up to 48 data cartridges. The rotating drum has four faces (A-D) and each face has 12 bins.
- Handler – grabs, holds, and provides the Z-axis movement (in/out) of data cartridges to/from the rotary storage drum bins or installed tape drive(s).
- Elevator – provides the Y-axis movement (up/down) that moves the data cartridges between the rotary storage drum and installed tape drive(s).
- Control Circuitry – provides overall control of the rotary storage drum position, movement and positioning of the Elevator and Handler, and reading the bar code data. Both local operation and remote operation are available.

### 1.3.2. TAPE DRIVES

Currently, two types of tape drives can be installed in the RSS-48b; however all drives installed must be the same type. Each drive uses helical-scan techniques to store and retrieve digital data.

- RSP-2150 (Standard) – up to two drives can be installed. Each drive stores more than 14 gigabytes of digital data on a DDC-258 ST-120 data tape cartridge. For more information about the RSP-2150, refer to the RSP-2150 User's Guide.
- VLDS (Very Large Data Store) (Optional) – up to two drives can be installed. Each drive stores up to 10.4 gigabytes of digital data on a standard commercial ST-120 tape cartridge. For more information about the VLDS, refer to the VLDS and RAW VLDS technical manuals.

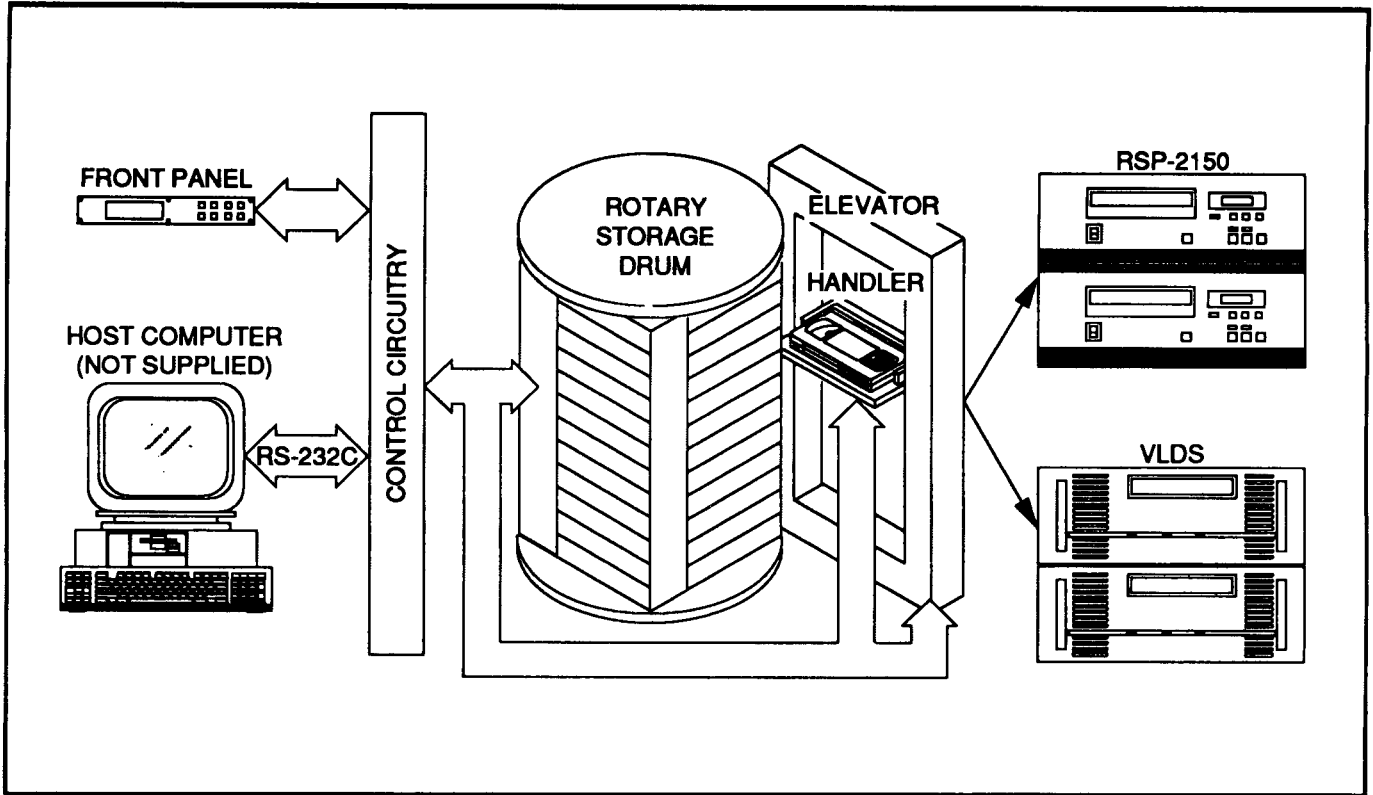

Figure 1-1 RSS-48b Functional Diagram

## 1.4. ACCESSORIES SUPPLIED

An accessory kit (packaged separately) is included with each RSS-48b, and contains the following items:

- **Power Cable (US and Canada):** Terminated with the standard 115V U.S. grounded wall plug, for use in the United States and Canada. See Chapter 2 for more information.
- **Power Cable (Harmonized):** Not terminated with a wall plug, for use outside the US and Canada. See Chapter 2 for more information.
- **Strain Relief:** For use with the power cable. See Chapter 2 for more information.
- **Drive Mounting Brackets and Hardware:** Slide brackets and hardware required to mount brackets on two RSP-2150 and/or VLDS Tape Drives.
- **Keys:** Two ACE® type keys for the front door are provided.
- **Blank Drive Panels:** Two Blank Drive Panels installed on the Cartridge Loader.
- **Ferrite Core:** Two core halves used on the communication cable.

## 1.5. ACCESSORIES AVAILABLE

The following accessories are available for use with the RSS-48b. See Section 6 for information on ordering accessories.

- **Additional Keys:** Contact your Distributor for more information on spare keys.
- **Bar Code Labels:** For identifying data cartridges. Either standard labels (numbered 01-50), or special order customized labels are available. Contact your Distributor for more information on custom labels.
- **Data Cartridges:** Specification controlled DDC-258 data cartridges for use with all Metrum tape drives.
- **RS-232C Serial Interconnect Cable:** See Chapter 2 for more information.

**NOTE** For a list of Tape Drive accessories available (e.g., interface options, etc) see the Tape Drive manuals.

**NOTE** RSP-2150 and VLDS Tape Drives use the same mounting hardware in a different configuration. Instructions to change RSP-2150/VLDS Tape Drives are available by contacting your Distributor.

- **CCA Extender Card:** 36-pin extender card used for troubleshooting.
- **VLDS Mounting Kit:** Brackets and slides for mounting VLDS Tape Drive(s).



## 1.6. OPTIONS

The standard RSS-48b is configured for two RSP-2150 Tape Drives, but can be optionally configured for two VLDS Tape Drives.

## 1.7. IDENTIFICATION

The model number is located on the rear panel of the RSS-48b.

The serial number located on the same plate is in the form 02 00170 B E93.

<b>M E T R U M , I n c .</b>	
<b>MODEL</b>	<b>RSS-48b</b>
<b>SER. NO.</b>	02 [REDACTED]
<b>S. O. NO.</b>	R00 [REDACTED]
<b>VOLTAGE</b>	<b>100 / 117 / 220 / 230 VAC</b>
<b>CURRENT</b>	<b>10 / 10 / 5 / 5 AMP</b>
<b>FREQ.</b>	<b>50 / 60 Hz</b>
	 LISTED 71G8
	EDP EQUIPMENT
	 MFG. 28009

Where;

02 is product series I.D. number.

00170 is the sequence number.

B is the model (matches the Model No. suffix).

E93 is the build date code (month/year).

A = January	G = July
B = February	H = August
C = March	J = September
D = April	K = October
E = May	L = November
F = June	M = December

The sales number located on the same plate is unique for each sales agreement.

## 1.8. CONFIGURATION

The original manufacturers identification label is located on the rear panel and inside the front door (chassis floor) of the RSS-48b. This label contains the model number, operating voltage, current, and frequency requirements.

The certification area on an interior plate lists the regulatory agencies whose requirements the RSS-48b has been tested against.

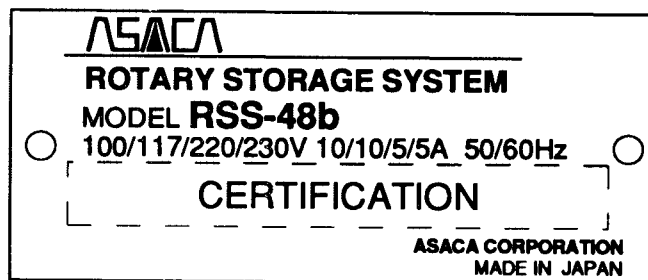

Where;



Underwriters Recognized.



Canadian Standards Association.



Verband Deutscher Elektrotechniker.



German Safety.

The serial number located on the same plate is in the form of a six digit sequential number is unique for each unit.

## 1.9. WARRANTY

Warranty terms and conditions vary dependent on the equipment configuration, manufacturer, distributor, and/or purchase agreement. For specific information on warranty terms and conditions, contact the Distributor.



## 2. INSTALLATION

---

### 2.1. GENERAL

This section provides unpacking, installation, initial turn-on, and operational check-out instructions for the RSS-48b.

#### WARNING

These installation instructions are for use by qualified personnel only. To avoid electric shock, do not remove covers or perform procedures unless you are qualified to do so.

#### WARNUNG

Diese Bedienungsanleitung ist ausschließlich für qualifiziertes Personal bestimmt. Um elektrische Schocks zu vermeiden, darf nur qualifiziertes Personal Abdeckungen entfernen oder Arbeiten durchführen.

#### AVERTISSEMENT

Ces instructions d'installation s'adressent à du personnel compétent seulement. Pour éviter tout choc électrique, ne retirez pas les garnitures et n'entreprenez aucune procédure à moins d'être qualifié pour le faire.

#### CAUTION

This equipment contains ESDS devices. Proper ESDS device handling procedures must be followed. Refer to the ESDS DEVICE HANDLING information at the front of this manual.

## 2.2. SAFETY PRECAUTIONS

### 2.2.1. ELECTRICAL SAFETY

**WARNING**

HIGH LEAKAGE CURRENT (>5 ma). Earth connection essential before connecting supply.

**WARNUNG**

Kriechstrom von mehr als 5 mA kann vorhanden sein.

**AVERTISSEMENT**

Un courant d'excitation de plus de 5 mA peut exister.

**WARNING**

The RSS-48b contains dangerous high voltages. CARELESS OR IMPROPER HANDLING CAN RESULT IN SERIOUS ELECTRIC SHOCK. NEVER perform installation of power cables or selection of input voltage with power applied.

**WARNUNG**

Die RSS-48b enthält gefährliche Hochspannungen. UNACHTSAME ODER UNSACHGEMÄSSE HANDHABUNG KANN ZU ERNSTHAFTEM ELEKTRISCHEM SCHOCK FÜHREN. Niemals Installation von Netzkabeln oder Auswahl der Eingangsspannung bei vorhandener Stromzufuhr durchführen.

**AVERTISSEMENT**

Le RSS-48b contient des composants sous haute tension dangereux. UNE MANIPULATION INADÉQUATE OU NE RESPECTANT PAS LES PRÉCAUTIONS VOULUES PRÉSENTE DE GRAVES RISQUES D'ÉLECTROCUTION. Ne jamais effectuer l'installation des câbles électriques ou la sélection de la tension d'entrée quand l'unité est sous tension.

## 2.2.2. MECHANICAL SAFETY

### WARNING

A minimum of 2 persons are required when unpacking or moving the RSS-48b. The RSS-48b weighs ~ 800 lbs (360 kg) and, when the leveling pads are retracted, will roll freely on its built in rollers. USE EXTREME CAUTION when rolling the RSS-48b. If the RSS-48b is allowed to roll uncontrolled, serious bodily injury and/or equipment damage may result.

### WARNUNG

Mindestens 2 Personen sind zum Transportieren der RSS-48b erforderlich. Die Einheit wiegt ca. 360 kg (800 Pfund) und läuft frei auf den eingebauten Rollen, wenn die Ausrichtungskonsolen eingezogen sind. **ÄUSSERSTE VORSICHT WALTEN LASSEN**, wenn die RSS-48b die Rampe hinuntergerollt wird. Wenn die RSS-48b unkontrolliert die Rampe hinunterrollt, kann das zu ernsthafter Körperverletzung bzw. Geräteschaden führen.

### AVERTISSEMENT

Il faut au minimum 2 personnes pour déplacer le RSS-48b. L'unité pèse environ 360 kg (800 lbs) et, quand le dispositif de mise à niveau est rétracté, roule librement sur ses roulettes incorporées. **EXERCER UNE EXTRÊME PRUDENCE** lorsque l'on déplace le RSS-48b. Si on laisse rouler le RSS-48b sans le contrôler, on s'expose à des blessures et/ou à des dégâts matériels graves.

## 2.3. EQUIPMENT REQUIRED

Table 2-1 provides a list of recommended tools and test equipment required for use when unpacking and installing the RSS-48b.

Table 2-1. Required Equipment

DESCRIPTION	MODEL	USE*
Digital Multimeter	Fluke 77	I
Flat Bladed Screwdriver	N/A	I/U
Hex-drive set (2.5 mm to 4 mm)	N/A	I/U
Open end wrench set (3/8 to 5/8)	N/A	I/U
Open end wrench set (4 mm to 11 mm, 32mm)	N/A	I/U
Phillips Screwdriver	N/A	I/U
Bubble Level	N/A	I

\* P=Packing, U=Unpacking, I=Installation

## 2.4. SITE REQUIREMENTS

The following environmental, electrical, physical, and safety requirements must be adhered to when choosing a location for installing and operating the RSS-48b. Failure to meet these requirements may degrade RSS-48b performance.

**NOTE** Both initial installation and any planned future expansion must be considered when choosing a location.

### 2.4.1. PHYSICAL REQUIREMENTS

The location chosen for RSS-48b operation must meet or exceed the following requirements:

- **Room** – must be large enough to provide space for storage, operation, and maintenance access (see Figure 2-1).
- **Passageways and Doorways** – from the receiving area to the installation location must be large enough for the RSS-48b to pass through (see Figure 2-1).
- **Floor** – must be able to support 800 pounds per square inch (psi) (56.36 kilograms per square centimeter). Raised floors are not required, however if used it must meet the following requirements:
  - must be able to support 800 psi.
  - sub-floor must be capable of supporting the raised floor and RSS-48b.
  - must have a hard surface.
  - must be flat (where RSS-48b is located) to within 1/16-inch per foot (0.52 cm per meter).
  - must have an access ramp that is one foot in length for every inch of raised floor height (e.g. 12 foot access ramp required for a raised floor 12 inches high).

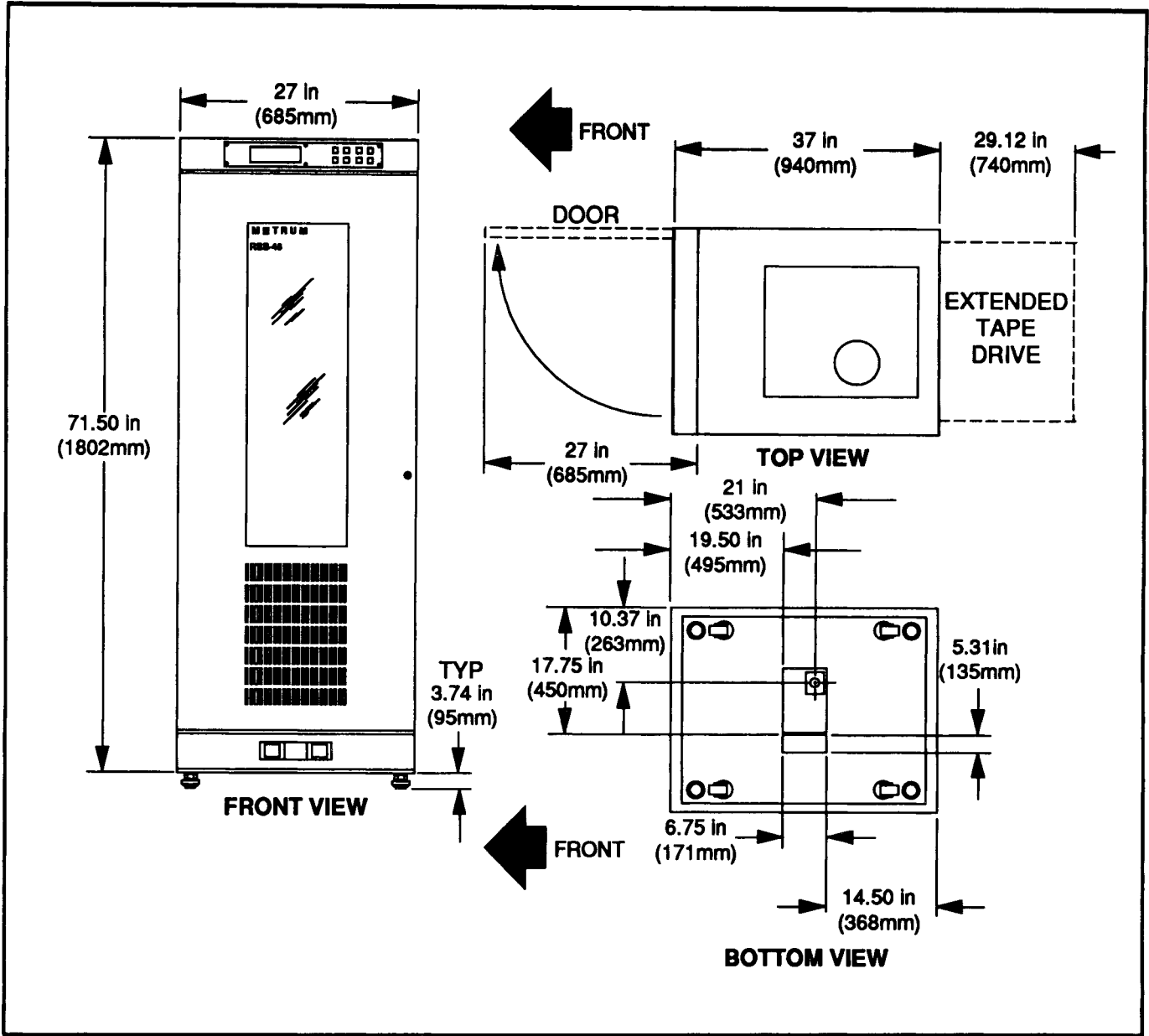

Figure 2-1. RSS-48b Outline Dimensions

- **Ceiling** – a minimum of 8-foot vertical clearance from floor to ceiling (recessed lighting and air-duct), or floor to fixture (hanging lighting or air-duct) is required. Ceiling tile used must be a non-shedding type that conforms to the class 10,000 clean-room environmental standards.
- **Lighting** – avoid using high intensity lighting where front panel display is used.

## 2.4.2. POWER REQUIREMENTS

The location chosen for RSS-48b operation must meet or exceed the following requirements:

- **Power** – 100/117/220/230 Vac  $\pm 10\%$ , 1,000 VA, 50/60 Hz, single phase power.
- **Outlet** – must be within 10 feet of the RSS-48b.
- **Nominal Service Capacity** – must be 10A (@100/117 Vac) or 5A (@220/230 Vac).
- **Wiring** – observe all electrical-wiring code requirements. In addition, a shunt trip for emergency power off at each exit should be provided. Also, clearly mark any electrical hazards associated with RSS-48b operation.
  - An insulated grounding conductor that is identical in size, insulation material, and thickness to the grounded and ungrounded branch-circuit supply conductors except that it is green with or without one or more yellow stripes is to be installed as part of the branch circuit that supplies the unit or system.
  - The grounding conductor mentioned above is to be grounded to earth at the service equipment or other acceptable building earth ground such as the building frame in the case of a high-rise steel-frame structure.

## 2.4.3. ENVIRONMENTAL REQUIREMENTS

The location chosen for RSS-48b operation must meet the following requirements:

- **Temperature** – from +41°F to +90°F (+5°C to +35°C). Non-operating temperature range is from -23°F to +140°F (-5°C to +40°C).
- **Temperature Change** – room temperature must not fluctuate more than 18°F (10°C) per hour. Non-operating temperature fluctuation must not exceed 36°F (20°C) per hour.
- **Humidity** – recommended humidity range is from 40% to 60% non-condensing to minimize static electricity problems. Maximum operating humidity range is from 20% to 80% non-condensing. Maximum non-operating humidity is 90% non-condensing.
- **Humidity Change** – humidity must not fluctuate more than 10% per hour.
- **Altitude** – maximum altitude is 10,500 feet (2,000 meters).
- **Radio Frequency Interference (RFI)** – do not install RSS-48b next to equipment that generates RFI, excessive electrical noise, or transients.

**WARNING**

The RSS-48b generates, uses, and can radiate radio frequency energy. Refer to the **WARNINGS** and **SAFETY** Information at the front of this manual for more information.

**WARNUNG**

Die RSS-48b erzeugt und verwendet Hochfrequenzenergie und strahlt sie u.U. auch aus. Auskünfte hierüber befinden sich in den **WARNUNGEN** und **SICHERHEITS**-Informationen am Anfang dieser Betriebsanleitung.

**AVERTISSEMENT**

Le RSS-48b produit, utilise et peut rayonner de l'énergie radioélectrique. Lisez les **AVERTISSEMENTS** et l'information sur la **SÉCURITÉ** au début du présent manuel pour obtenir plus de renseignements.

- **Air Conditioning** – the room must be able to dissipate 1,200 BTU's (150 Kcal).
- **Air Quality** – dust or airborne pollutants must not exceed 300,000 ppm (clean room specification).

#### 2.4.4. **SAFETY REQUIREMENTS**

The location chosen for RSS-48b operation must meet or exceed the following requirements:

- **Overall Safety** – all exits from the room should be clearly marked, and doors should open out from a recessed doorway. Cabinet access doors should not obstruct the flow of foot traffic when open. A clear exit path, free of physical obstructions should be maintained at all times.
- **Fire Safety** – facility must comply with local and national fire protection and safety codes. In addition, fire/smoke detectors should be configured to power down all electrical equipment when fire hazard is detected. Use CO<sub>2</sub> and Halon type extinguishers near the RSS-48b (do not use Soda-Acid or Dry Powder type extinguishers).

## 2.5. UNPACKING

The following instructions are provided to uncrate the RSS-48b.

### WARNING

A minimum of 2 persons are required to unpack the RSS-48b. The unit weighs approximately 800 lbs (360 kg) and, when the leveling pads are retracted, will roll freely on its built-in rollers. **USE EXTREME CAUTION** when rolling the RSS-48b down the ramp. If the RSS-48b is allowed to roll down the ramp uncontrolled, serious bodily injury and/or equipment damage may result. Read these instructions completely prior to unpacking the RSS-48b.

### WARNUNG

Mindestens 2 Personen sind zum Auspacken der RSS-48b erforderlich. Die Einheit wiegt ca. 360 kg (800 Pfund) und läuft frei auf den eingebauten Rollen, wenn die Ausrichtungskonsolen eingezogen sind. **ÄUSSERSTE VORSICHT WALTEN LASSEN**, wenn die RSS-48b die Rampe hinuntergerollt wird. Wenn die RSS-48b unkontrolliert die Rampe hinunterrollt, kann dies zu ernsthafter Körperverletzung bzw. Geräteschaden führen. Diese Anleitungen vor dem Auspacken der RSS-48b vollständig lesen.

### AVERTISSEMENT

Il faut au minimum 2 personnes pour déballer le RSS-48b. L'unité pèse environ 360 kg (800 lbs) et, quand le dispositif de mise à niveau est rétracté, roule librement sur ses roulettes incorporées. **EXERCER UNE PRUDENCE EXTRÊME** lorsque l'on fait rouler le RSS-48b en descendant la rampe de déchargement. Si on laisse le RSS-48b descendre la rampe sans le contrôler, on s'expose à des blessures et/ou à des dégâts matériels graves. Lire toutes les présentes instructions avant de déballer le RSS-48b.

Prior to unpacking the RSS-48b, inspect the shipping crate for indications of possible damage. Pay particular attention to the 50G/25G impact and vertical tip indicators. If there is an indication that the crate has been subject to high impact, tilted more than 30°, or sustained any other serious damage, immediately contact the carrier and your Distributor.

Unpackage the RSS-48b as follows (see Figure 2-2):

1. Remove twenty-four  $\frac{3}{8}$  x 6  $\frac{1}{4}$  bolts & washers retaining the **REAR** panel and the **FRONT** cover/ramp combination.
2. Remove two  $\frac{1}{4}$  x 2 screws and washers retaining the end cap to the front cover/ramp.

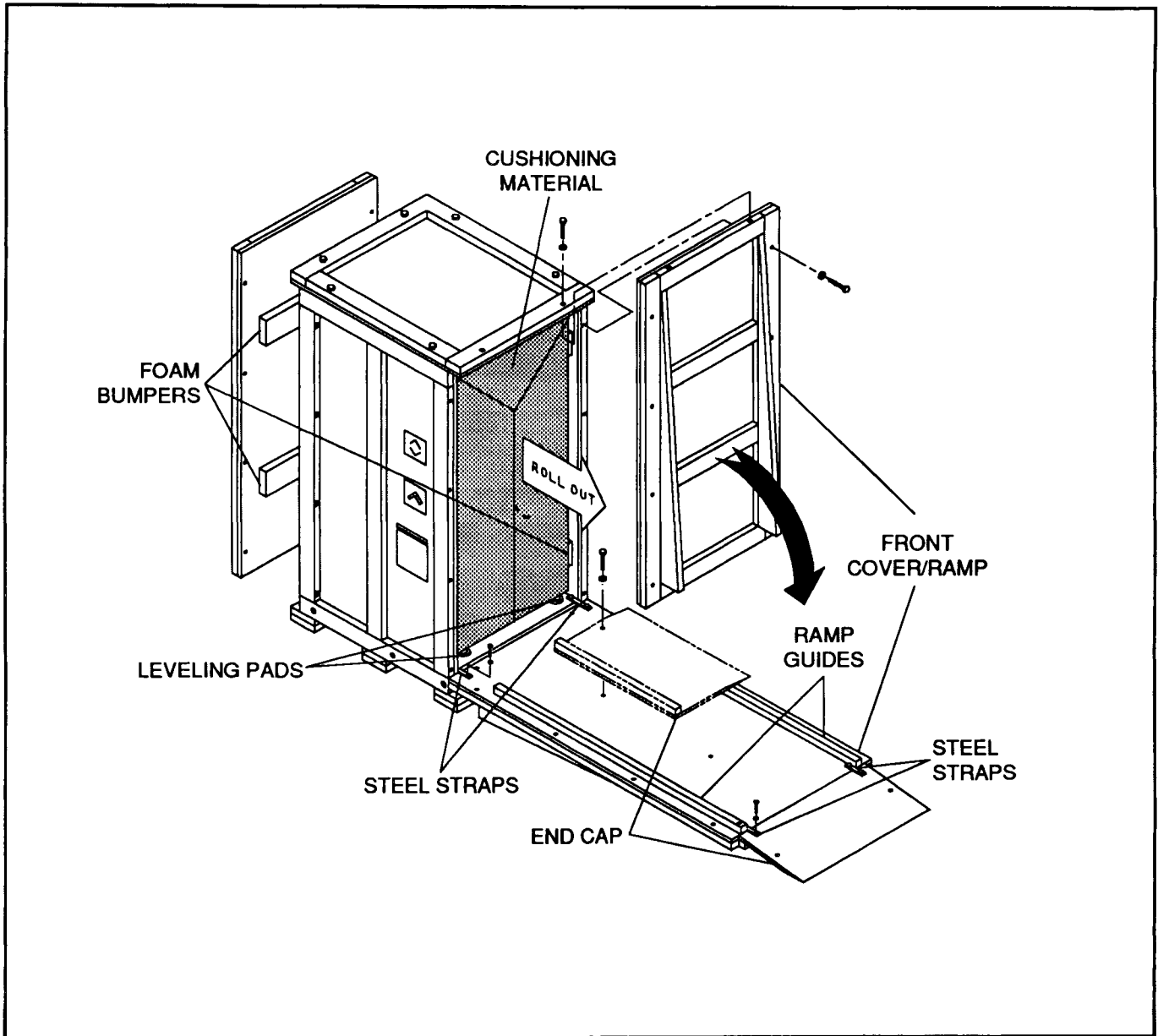

Figure 2-2. RSS-48b Unpacking

3. Position the cover/ramp combination and end cap in front of the crate as shown in Figure 2-2, and secure using eight  $\frac{1}{4}$  x 2 screws and four steel straps provided.
4. Rotate the four leveling pads (front and rear) until fully retracted (up position).

**WARNING**

A minimum of 2 persons are required to perform the next step. If the unit is allowed to roll down the ramp uncontrolled, serious bodily injury and/or equipment damage may result.

**WARNUNG**

Mindestens 2 Personen sind zur Ausführung des nächsten Schrittes erforderlich. Wenn das Gerät unkontrolliert die Rampe hinunterrollt, kann das zu ernsthafter Körperverletzung bzw. Geräteschaden führen.

**AVERTISSEMENT**

Il faut au minimum 2 personnes pour effectuer l'opération suivante. Si on laisse tomber l'ensemble de chargeur à cartouche, on s'expose à des blessures et/ou à des dégâts matériels graves.

**CAUTION**

Always push the RSS-48b using the lower corners of the cabinet. NEVER push on the center of any panel or permanent damage may result. Because the RSS-48b is top heavy, do not move by pushing on the upper portion of the unit.

5. Push the RSS-48b from the rear of the crate towards the ramp. While removing:
  - Push on the corners of the cabinet. Do not push on the center of any panel.
  - Keep front square with the crate opening so the sides of the RSS-48b do not bind with the foam bumpers inside of the crate.
  - Guide the RSS-48b so it rolls between both ramp guides.
  - Slowly roll the RSS-48b down the ramp always keeping it between both ramp guides.
6. Once the RSS-48b is off the ramp, roll to level area.
7. Remove cushioning material and inspect the RSS-48b for signs of shipping damage. Any damage should be immediately reported to the carrier and to your Distributor.
8. Disassemble and retain the shipping crate and packing materials for use when storing or reshipping the RSS-48b.

## 2.6. PLACING/LEVELING

The following instructions are provided to position and level the RSS-48b.

### WARNING

A minimum of 2 persons are required to move the RSS-48b. The RSS-48b weighs approximately 800 lbs (360 kg) and, when the leveling pads are retracted, will roll freely on its built-in rollers. **USE EXTREME CAUTION** when moving the RSS-48b. If the RSS-48b is allowed to roll uncontrolled, serious bodily injury and/or equipment damage may result.

### WARNUNG

Mindestens 2 Personen sind zum Transportieren der RSS-48b erforderlich. Die Einheit wiegt ca. 360 kg (800 Pfund) und läuft frei auf den eingebauten Rollen, wenn die Ausrichtungskonsolen eingezogen sind. **ÄUSSERSTE VORSICHT WALTEN LASSEN**, wenn die RSS-48b die Rampe hinuntergerollt wird. Wenn die RSS-48b unkontrolliert die Rampe hinunterrollt, kann das zu ernsthafter Körperverletzung bzw. Geräteschaden führen.

### AVERTISSEMENT

Il faut au minimum 2 personnes pour déplacer le RSS-48b. L'unité pèse environ 360 kg (800 lbs) et, quand le dispositif de mise à niveau est rétracté, roule librement sur ses roulettes incorporées. **EXERCER UNE PRUDENCE EXTRÊME** lorsque l'on déplace le RSS-48b. Si on laisse rouler le RSS-48b sans le contrôler, on s'expose à des blessures et/ou à des dégâts matériels graves.

### CAUTION

Always push the RSS-48b using the lower corners of the cabinet. **NEVER** push on the center of any panel or permanent damage may result. Because the RSS-48b is top heavy, do not move by pushing on the upper portion of the unit.

Prior to placing and leveling the RSS-48b:

- a proper site must be chosen using the guidelines described in paragraph 2-4.
- the RSS-48b must be uncrated using the instructions provided in paragraph 2-5.

Position and level the RSS-48b as follows (see Figure 2-3):

1. Move the RSS-48b to the desired location. Remember to push on the corners of the cabinet, not on the center of any panel.
2. Rotate the four leveling pads until each touches the floor. Using a 32 mm open ended wrench, continue turning each leveling pad one-full turn.
3. Determine the high corner using a bubble level. Place the bubble level as shown in Figure 2-3 and adjust the three remaining leveling pads until the RSS-48b is level.

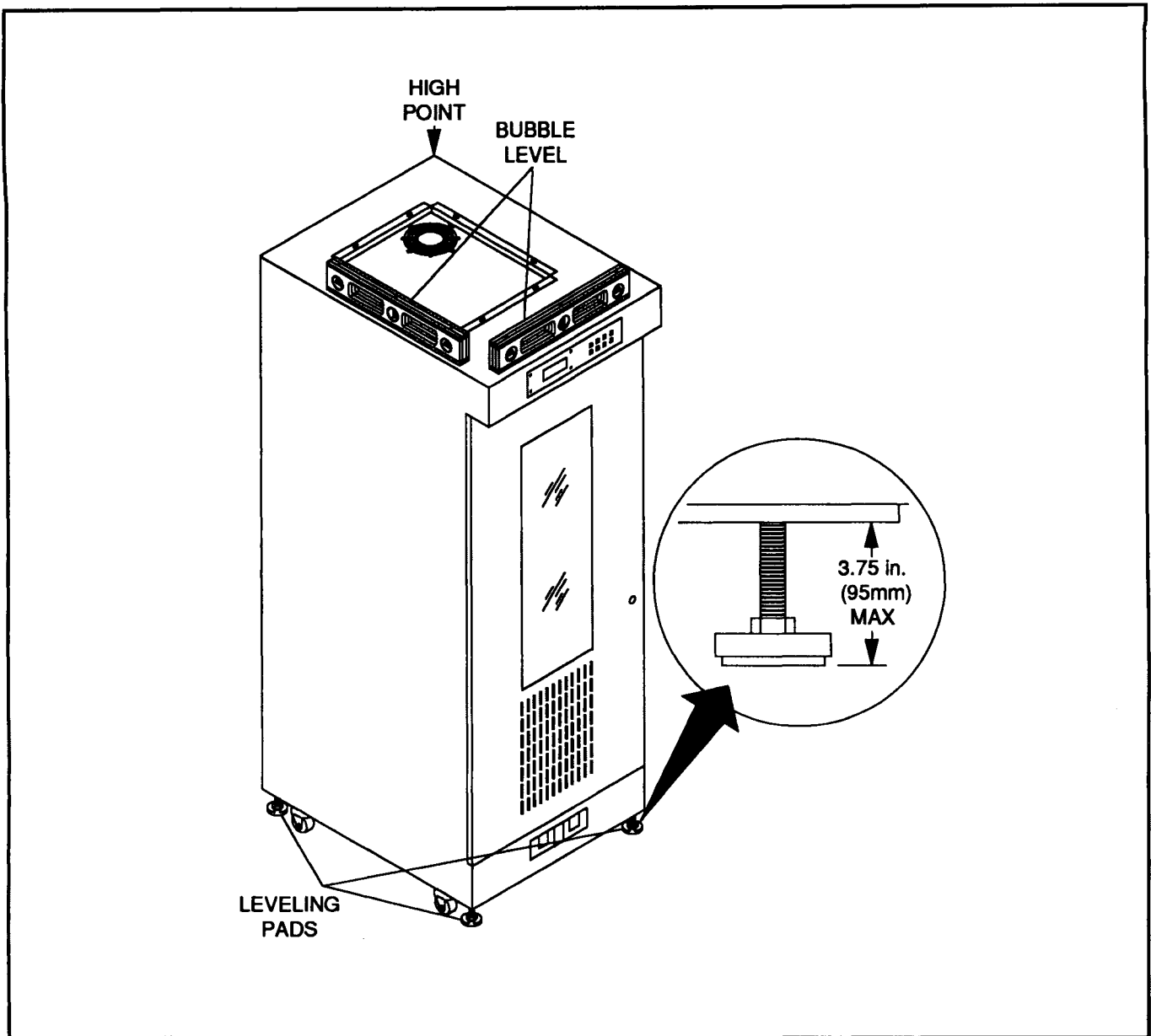

Figure 2-3. RSS-48b Placing and Leveling

## 2.7. INSTALLATION

The following instructions are provided to prepare the RSS-48b for operation. Instructions are provided to remove all internal packing material and shipping brackets, install the tape drives, and connect power and communication cables.

Prior to installing the RSS-48b:

- a proper site must be chosen using the guidelines described in paragraph 2-4.
- the RSS-48b must be uncrated using the instructions provided in paragraph 2-5.
- the RSS-48b must be placed and leveled using the instructions provided in paragraph 2-6.

## 2.7.1. SHIPPING BRACKETS

Remove packing material and shipping brackets inside of the RSS-48b as follows (see Figure 2-4):

1. Remove the cardboard covering the circuit breaker and control panel areas.
2. Open the front door (key is in the box with accessories).
3. Remove two M5 x 10 hex drive screws and washers on the top of the Cartridge Loader Assembly.

### WARNING

A minimum of 2 persons are required to perform the next step. If the Cartridge Loader Assembly is allowed to drop uncontrolled, serious bodily injury and/or equipment damage may result.

### WARNUNG

Mindestens 2 Personen sind zur Ausführung des nächsten Schrittes erforderlich. Wenn die Patronenladeeinheit unkontrolliert fallen gelassen wird, kann das zu ernsthafter Körperverletzung bzw. Geräteschaden führen.

### AVERTISSEMENT

Il faut au minimum 2 personnes pour effectuer l'opération suivante. Si on laisse tomber l'ensemble de chargeur à cartouche, on s'expose à des blessures et/ou à des dégâts matériels graves.

4. Loosen the two knurled fastening screws and lower the Cartridge Loader Assembly to the floor. While lowering the Cartridge Loader Assembly, make sure the cable harness on the lower left and right corners are free.
5. Remove the two foam wedges securing the rotary storage drum, and cushioning material around the Handler Assembly.
6. Remove two drive belt retainers, and both foam blocks above and below the Flat Ribbon Guide Roller.
7. Remove the upper and/or lower drive panel(s) depending on the number and location of drives being installed (four M4 x 10 hex drive screws each).
8. Remove the left front shipping bracket (four M4 x 10 and four M5 x 10 hex drive screws and washers).
9. Raise the Cartridge Loader Assembly and secure with knurled fastening screws and two M5 x 10 hex drive screws and washers. Close the front door.
10. Remove the top rear panel by rotating the fasteners until the slot is horizontal then lightly rap the upper corner with the palm of your hand.
11. Remove the right rear shipping bracket (four M4 x 10 and three M5 x 10 hex drive screws and washers).

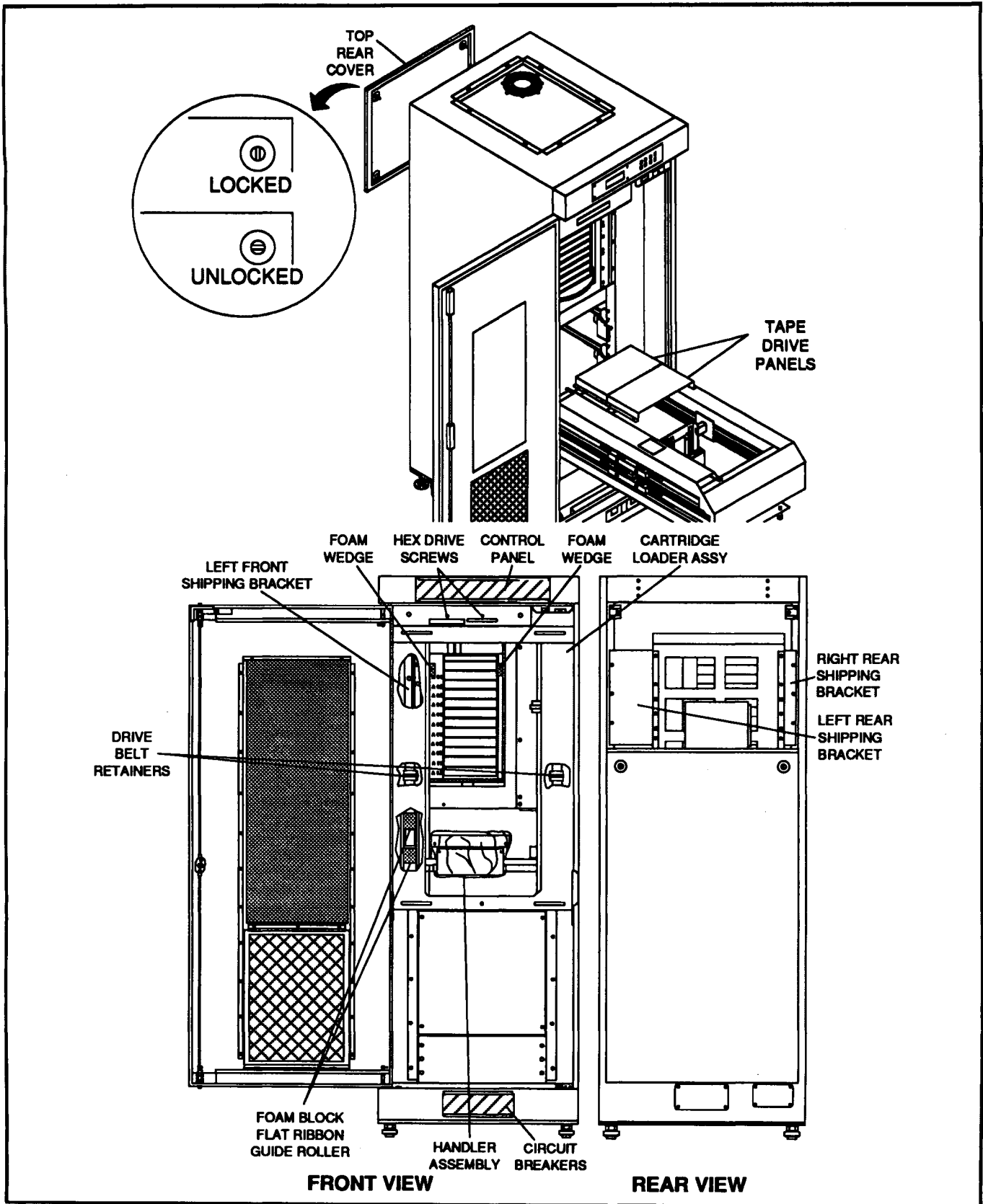

Figure 2-4. RSS-48b Shipping Brackets

12. Remove the left rear shipping bracket (four M4 x 10 and three M5 x 10 hex drive screws and washers). Replace the top rear panel.
13. Place shipping brackets, hardware, and packing material with disassembled shipping crate for use when storing or reshipping the RSS-48b.

**Power connection (paragraph 2.7.2) is provided in three languages (English, German, and French) for compliance of various US, Canadian, and European regulations. Page and paragraph numbers for each language are identical for reference purposes. If desired, the languages that are not used can be removed from the section and placed at the end of the manual.**

## 2.7.2. POWER CONNECTION

The RSS-48b is shipped from the factory ready to operate at 117 Vac (unless otherwise specified). All that is required for operation is connection of the supplied power cable using the instructions found in paragraph 2.7.2.3. The factory-set line voltage can be changed (if necessary) using the instructions found in paragraph 2.7.2.2.

### WARNING

The RSS-48b power cord contains a grounding conductor which connects the frame of the RSS-48b to earth ground when plugged into a properly-wired power receptacle. The power receptacle ground conductor must be connected to earth at the service equipment or other acceptable building earth ground. Do not attempt to operate this equipment without the earth ground connection.

### 2.7.2.1. Facility Power

Facility power for the RSS-48b must meet the following specifications:

- **Line Voltage:** 100, 117, 220, or 230 Vac,  $\pm 10\%$ .
- **Line Frequency:** 50 to 60 Hz.
- **Power Consumption:** 1,000 VA.

### 2.7.2.2. Line Voltage Setting

### WARNING

These procedures must be performed by Metrum-trained personnel familiar with local electrical codes and facility power wiring. Contact your distributor for assistance if necessary.

### CAUTION

When changing a 117 Vac RSS-48b to operate from 100, 220, or 230 Vac, it is necessary to change the power transformer jumper and power cable plug.

The voltage setting is indicated on the power transformer by the position of the wire jumper. The line voltage selected must match the facility power at the installation site, and can be changed as follows:

1. Set system and drive circuit breakers to off and unplug the power cable (if connected).
2. Remove the bottom rear panel by rotating the fasteners until the slot is horizontal then lightly rap the upper corner with the palm of your hand.
3. Change the wire jumper to the desired position (see Figure 2-5).

### CAUTION

The RSS-48b may be permanently damaged if power is applied with the wire jumper in the incorrect position.

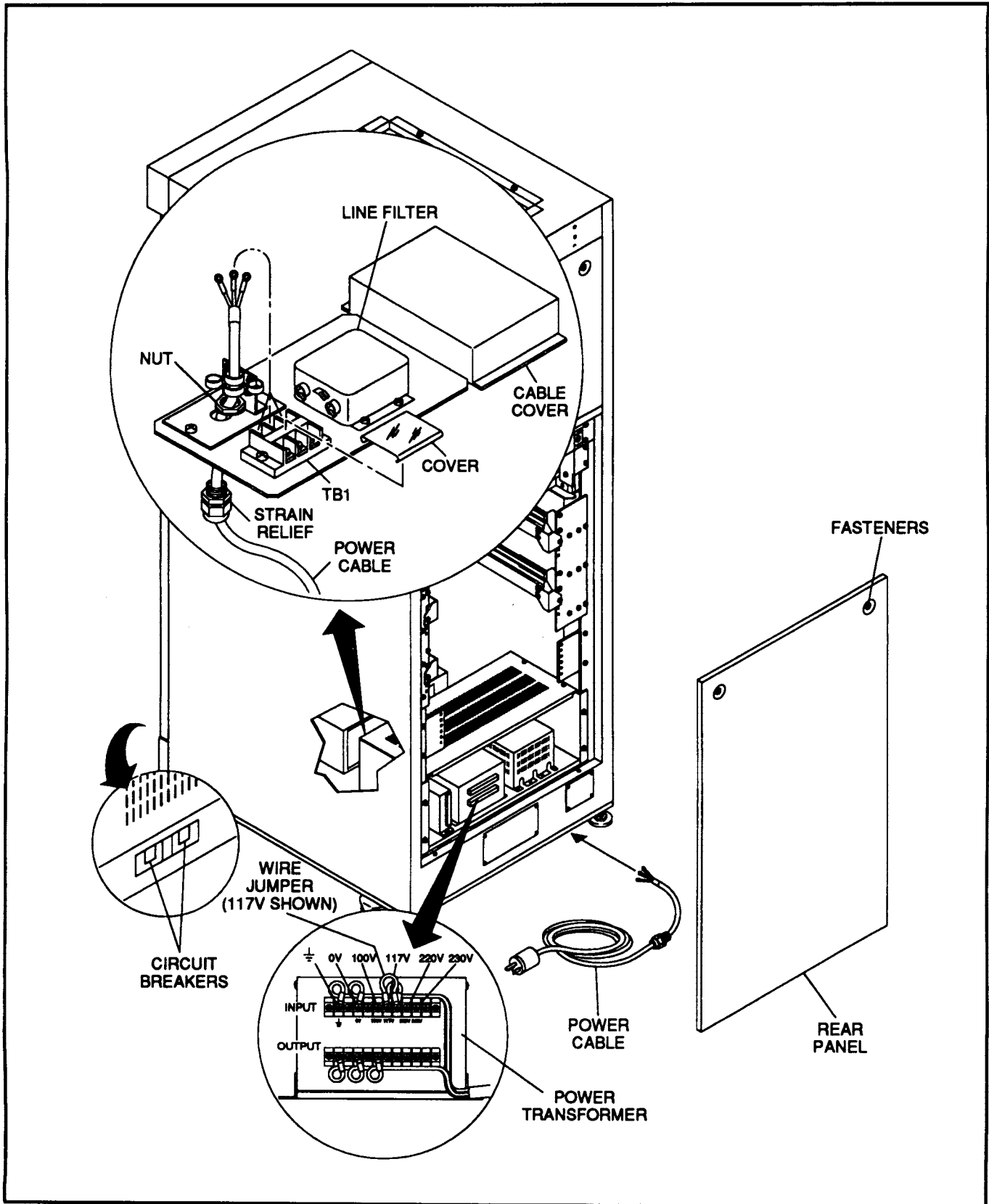

Figure 2-5. RSS-48b Voltage Selection and Power Connection

4. Configure each of the installed tape drive(s) to operate from the same power that the power transformer is set to operate at. Configuration instructions are provided in the User's Guide or Operator's Manual supplied with the tape drive.
5. Replace the rear panel.

### 2.7.2.3. Power Cable

**WARNING**

Do not use the supplied 117 Vac US/Canada wall plug to operate units from 100, 220, or 230 Vac, or outside the U.S. and Canada.

The supplied power cable is connected as follows:

1. Verify that both the front panel system and drive circuit breakers are set to OFF.
2. Prepare power cable as follows (see Section 6 for cable/wall plug part numbers):
  - For 117 Vac operation in the United States and Canada, use the wall plug already installed on the power cable. For 220/230Vac operation in the US, replace the 117Vac wall plug with an approved wall plug compliant with UL/CSA.
  - For operation in countries other than the United States and Canada, install an approved wall plug compliant with the country of installation onto the harmonized power cable. See Figure 2-6 for input terminal strip information, and Figure 2-7 for wall plug standards in various countries. Section 6 contains approved wall plug ordering information.
3. Remove the bottom rear panel by rotating the fasteners until the slot is horizontal then lightly rap the upper corner with the palm of your hand.
4. Feed the power cable with strain relief through the access hole in the bottom of the cabinet and cable loops as shown. Cable loops used are dependent on the outside diameter of the power cable (turn unused loops away from the cable).
5. Push strain relief through the bracket hole and secure using the nut. Tighten cable loop retaining screws.
6. Connect the power cable terminals to the power input terminal TB1 as shown (refer to Figure 2-6). Replace clear plastic covers.
7. Replace the rear panel.

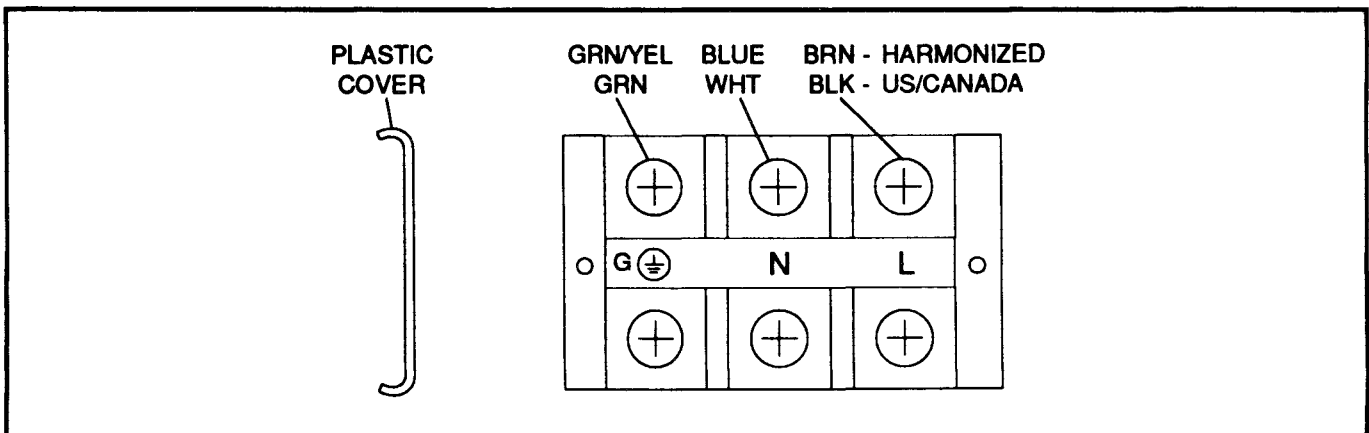

Figure 2-6. RSS-48b Power Input Block (TB1)

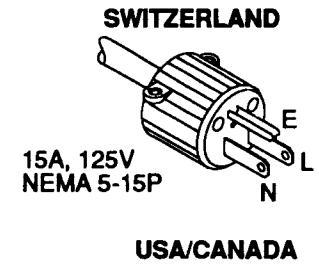
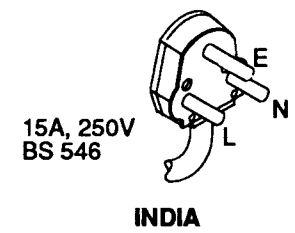
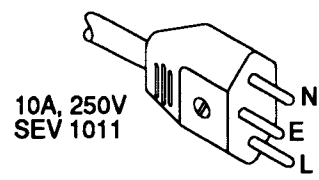
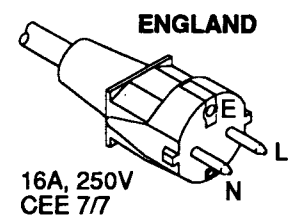
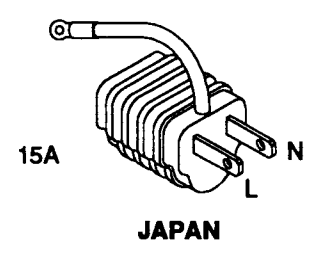
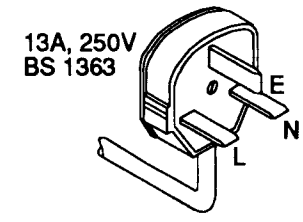
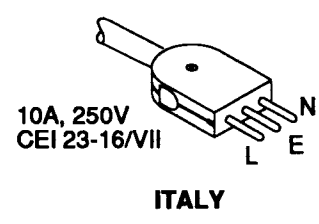
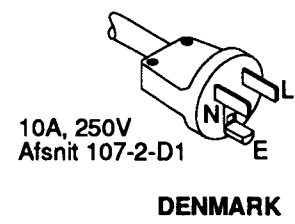
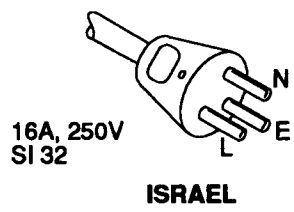
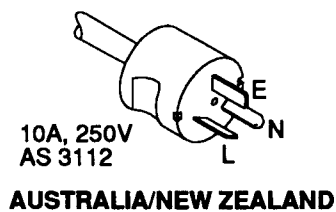

Figure 2-7. Power Cable Wall Plug Standards

4. Configure each of the installed tape drive(s) to operate from the same power that the power transformer is set to operate at. Configuration instructions are provided in the User's Guide or Operator's Manual supplied with the tape drive.
5. Replace the rear panel.

### 2.7.2.3. Power Cable

**WARNING**

Do not use the supplied 117 Vac US/Canada wall-plug to operate units from 100, 220, or 230 Vac, or outside the U.S. and Canada.

The supplied power cable is connected as follows:

1. Verify that both the front panel system and drive circuit breakers are set to OFF.
2. Prepare power cable as follows (see Section 6 for cable/wall plug part numbers):
  - For 117 Vac operation in the United States and Canada, use the wall-plug already installed on the power cable. For 220/230Vac operation in the US, replace the 117Vac wall plug with an approved wall-plug compliant with UL/CSA.
  - For operation in countries other than the United States and Canada, install an approved wall-plug compliant with the country of installation onto the harmonized power cable. See Figure 2-6 for input terminal strip information, and Figure 2-7 for wall plug standards in various countries. Section 6 contains approved wall plug ordering information.
3. Remove the bottom rear panel by rotating the fasteners until the slot is horizontal then lightly rap the upper corner with the palm of your hand.
4. Feed the power cable with strain relief through the access hole in the bottom of the cabinet and cable loops as shown. Cable loops used are dependent on the outside diameter of the power cable (turn unused loops away from the cable).
5. Push strain relief through the bracket hole and secure using the nut. Tighten cable loop retaining screws.
6. Connect the power cable terminals to the power input terminal TB1 as shown (refer to Figure 2-6). Replace clear plastic covers.
7. Replace the rear panel.

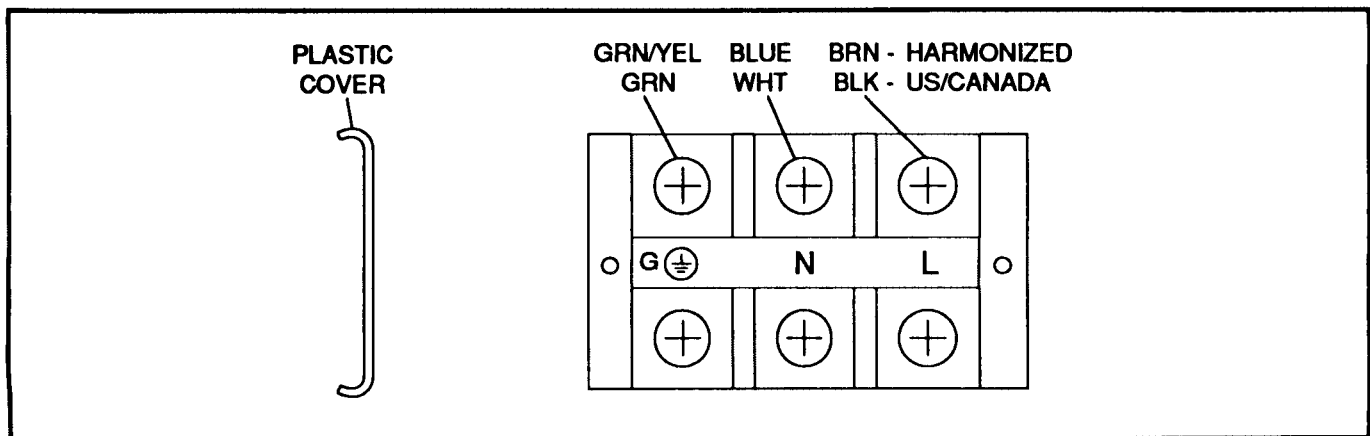

Figure 2-6. RSS-48b Power Input Block (TB1)

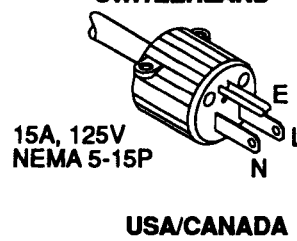
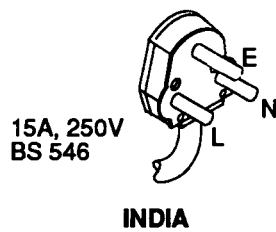
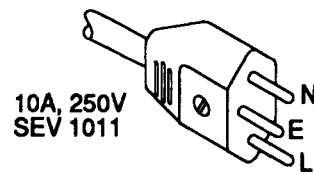
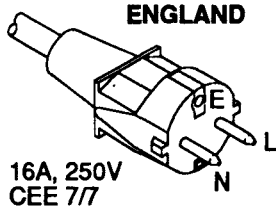
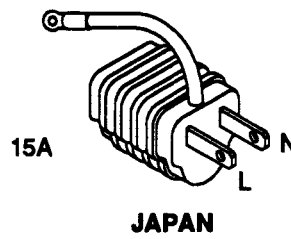
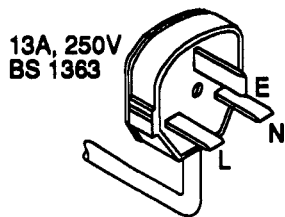
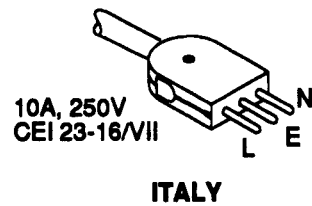
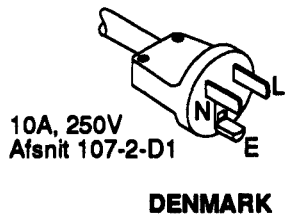
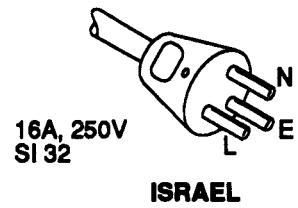
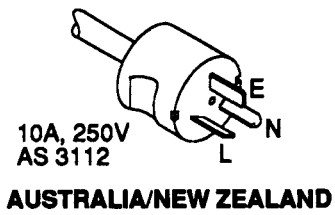

Figure 2-7. Power Cable Wall Plug Standards

## 2.7.2. STROMANSCHLUSS

Die RSS-48b wird vom Werk mit der Einstellung auf 117 Volt WS (außer wenn anders angegeben). Zum Betrieb ist lediglich der Anschluß des mitgelieferten Netzkabels entsprechend den Anleitungen in Abschnitt 2.7.2.3. erforderlich. Die vom Werk eingestellte Netzspannung kann (falls erforderlich) anhand der in Abschnitt 2.7.2.2. zu findenden Anleitungen geändert werden.

### WARNUNG

Das RSS-48b-Netzkabel enthält einen Schutzleiter, der den Rahmen der RSS-48b mit der Erde verbindet, wenn das Kabel in eine sachgemäß verdrahtete Steckdose gesteckt wird. Der Schutzkontakt der Steckdose muß an der Versorgungseinrichtung oder an einer anderen zugelassenen Gebäudeerdung mit der Erde verbunden sein. Versuchen Sie nicht, dieses Gerät ohne Erdung in Betrieb zu nehmen.

### 2.7.2.1. Anlagenspannung

Die Anlagenspannung für die RSS-48b muß den folgenden Spezifikationen entsprechen:

- **Netzspannung:** 100, 117, 220 oder 230 Volt WS  $\pm 10\%$ .
- **Netzfrequenz:** 50 bis 60 Hz.
- **Stromaufnahmen:** 1000 VA.

### 2.7.2.2. Netzspannungseinstellung

#### WARNUNG

Diese Verfahren dürfen nur von Personal durchgeführt werden, das sich mit den örtlichen Vorschriften und der Vernetzung auskennt. Setzen Sie sich sofern erforderlich mit Ihrem Vertriebl in Verbindung.

#### VORSICHT

Beim Ändern einer 117-Volt WS RSS-48b zum Betrieb mit 100, 220 oder 230 Volt WS müssen die Transformatorbrücke und der Stecker des Netzkabels geändert werden.

Die Spannungseinstellung ist am Transformator durch die Position der Kabelbrücke angezeigt. Die gewählte Netzspannung muß der Anlagenspannung am Installationsort entsprechen und kann wie folgt geändert werden:

1. Den Netzschalter auf AUS (OFF) schalten und das Netzkabel ausstecken (falls eingesteckt).
2. Die untere Rückwandplatte entfernen, in dem die Befestigungselemente gedreht werden, bis deren Schlitze horizontal liegen, und dann leicht mit der Faust gegen die obere Ecke klopfen.
3. Die Kabelbrücken in die gewünschte Stellung ändern. Siehe Abb. 2-5



Abbildung 2-5. RSS-48b Spannungswahl und Stromanschluß

**VORSICHT**

Die RSS-48b kann permanent beschädigt werden, wenn Strom bei falsch gesetzten Kabelbrücken eingeschaltet wird.

4. Jedes der installierten Bandlaufwerke so konfigurieren, daß sie von der gleichen Stromversorgung betrieben werden, auf die auch der Trafo eingestellt ist. Konfigurationsanleitungen sind im Benutzerleitfaden oder dem Bedienerhandbuch zu finden, die dem Bandlaufwerk beigelegt wurden.
5. Die Rückwandplatte wieder anbringen.

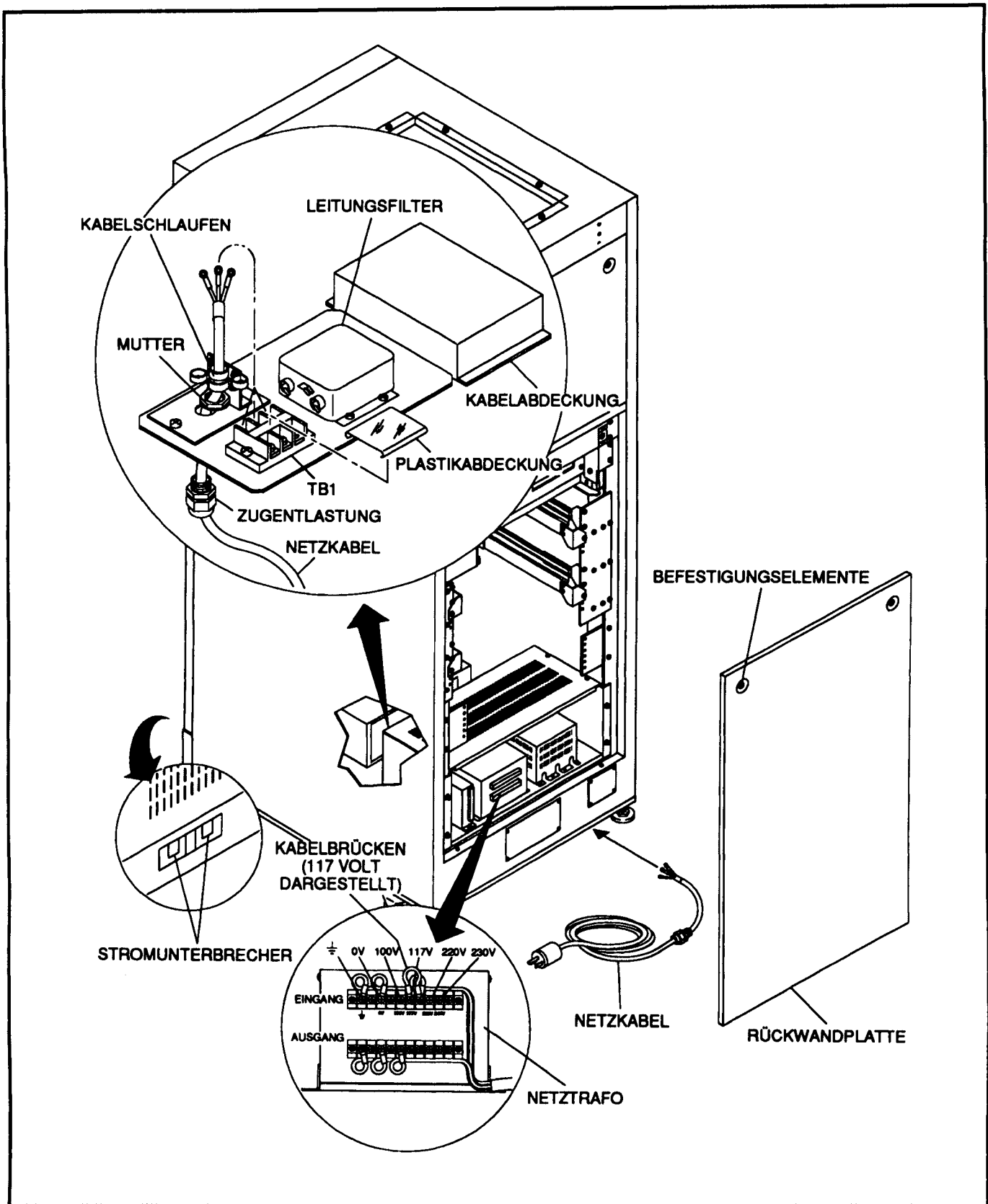
### 2.7.2.3. Netzkabel

**WARNUNG**

Den mitgelieferten 117 Volt WS Netzstecker nicht zum Betrieb des Gerätes mit 100, 220 oder 250 Volt WS oder außerhalb der U.S.A. oder Kanadas verwenden.

Das mitgelieferte Netzkabel wird wie folgt angeschlossen:

1. Sicherstellen, daß beide Netzschalter der Frontplatte auf AUS (OFF) stehen.
2. Das mitgelieferte Netzkabel wie folgt vorbereiten (see Section 6 for cable/wall plug part numbers):
  - Für 117-Volt WS Betrieb in den Vereinigten Staaten und Kanada den bereits am Netzkabel installierten Stecker verwenden. Bei 220 oder 230 Volt WS in den USA, den 117 Volt WS Netzstecker durch einen genehmigten Netzstecker ersetzen, der UL/CSA entspricht.
  - Beim Einsatz außerhalb der USA oder Kanadas, einen den Vorschriften des betreffenden Landes entsprechenden Netzstecker auf das passende Netzkabel setzen. Siehe Abb. 2-6 für Informationen über die Eingangsanschlußleiste und Abb. 2-7 für Informationen über Netzsteckernormen in den verschiedenen Ländern. Abschnitt 6 enthält Bestellinformationen für genehmigte Netzstecker.
3. Die untere Rückwandplatte entfernen, in dem die Befestigungselemente gedreht werden, bis deren Schlitz horizontal liegen, und dann leicht mit der Faust gegen die obere Ecke klopfen.



Abbildung 2-6. RSS-48b Stromeingang

4. Das Netzkabel mit Zugentlastung wie dargestellt durch die Öffnung auf der Unterseite des Schrankes und die Kabelschlaufen führen. Die zu verwendenden Kabelschlaufen richten sich nach dem Außendurchmesser des Netzkabels (nicht verwendete Schlaufen vom Netzkabel wegrehen).
5. Die Zugentlastung durch das Loch in der Konsole führen und mit der Mutter befestigen. Die Kabelschlaufen mit Befestigungsschrauben festziehen.
6. Die Netzkabelklemmen wie dargestellt an den Leistungsanschluß TB1 anschließen (siehe Abb. 2-6). Die Plastikabdeckungen wieder aufsetzen.
7. Die Rückwandplatte wieder anbringen.

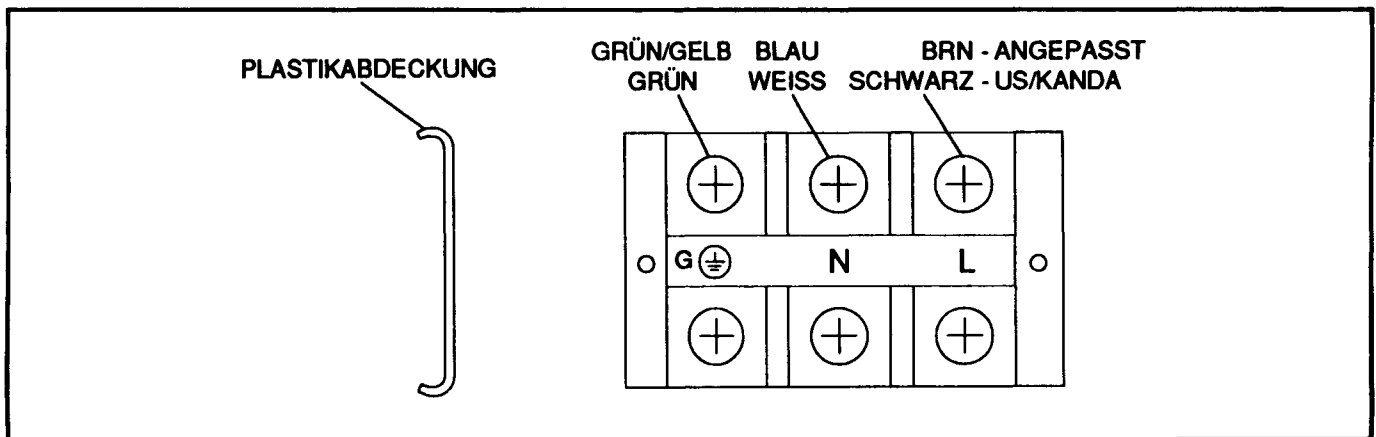

Abbildung 2-7. Netzkabelstecker-Normen

## 2.7.2. ALIMENTATION DU RSS-48b

Le RSS-48b est expédié de l'usine prêt à fonctionner sur courant à 117 VCA (à moins d'indication contraire). Il suffit tout simplement de brancher le câble d'alimentation fourni selon les instructions figurant au paragraphe 2.7.2.3. Le réglage de tension effectué en usine peut être modifié (si nécessaire) selon les instructions figurant au paragraphe 2.7.2.2.

### AVERTISSEMENT

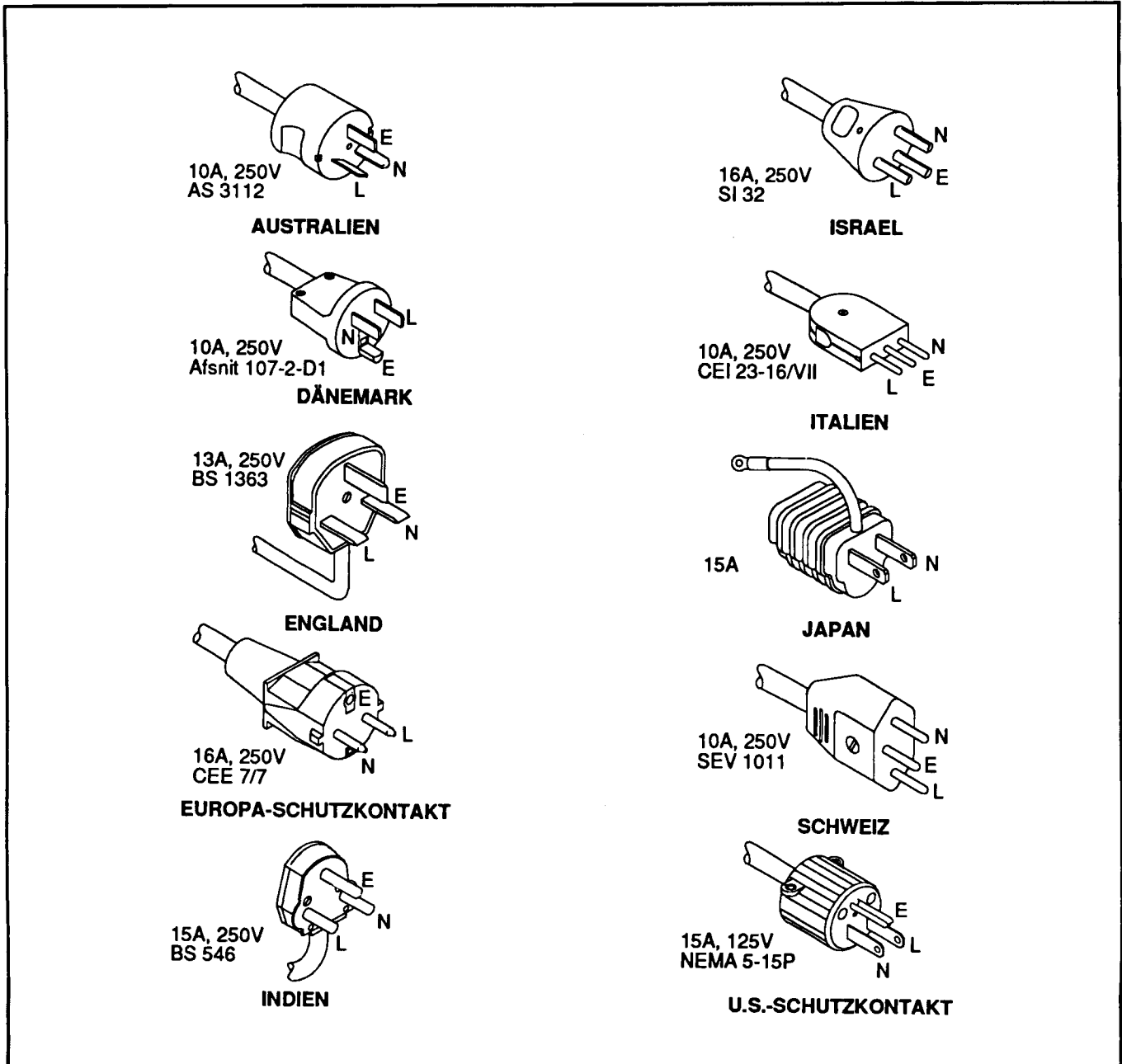
Le cordon d'alimentation du RSS-48b possède un fil de mise à la terre qui relie le châssis du RSS-48b à la terre lorsqu'il est enfiché dans une prise électrique adéquatement câblée. Le fil de terre de la prise électrique doit être relié à la terre au point de branchement ou à un autre point acceptable de mise à la terre de l'édifice. Ne pas essayer de faire fonctionner l'appareil sans qu'il soit raccordé à la terre.

### 2.7.2.1. Réseau d'alimentation

Le réseau d'alimentation auquel on raccorde le RSS-48b doit présenter les caractéristiques ci-bas :

- Tension de réseau: 100, 117, 220 ou 230 Vca,  $\pm 10\%$ .
- Fréquence: 50 à 60 Hz
- Consommation: 1000 VA

### 2.7.2.2. Réglage de la tension de ligne

#### AVERTISSEMENT

Ces procédures doivent être effectuées par du personnel formé, connaissant bien les codes d'électricité locaux ainsi que les installations électriques de l'endroit. Au besoin, communiquez avec votre distributeur pour toute assistance.

#### ATTENTION

Lorsque l'on règle un RSS-48b pré-réglé à 117 VCA pour l'utiliser sur courant à 100, 220 ou 230 VCA, il faut changer la position du cavalier du transformateur et la fiche du câble d'alimentation.

La valeur de la tension est indiquée sur le transformateur par la position du cavalier. La tension de ligne sélectionnée doit correspondre à la tension du réseau d'alimentation du site d'installation. Pour régler la tension de ligne, procéder comme suit :

1. Mettre le commutateur en position d'arrêt (OFF) et débrancher le câble d'alimentation de la prise murale.
2. Démontez le panneau arrière inférieur en faisant pivoter les attaches pour amener la rainure en position horizontale, puis en tapant légèrement sur le coin supérieur avec le poing.
3. Placer le cavalier à la position voulue. Voir la figure 2-5.

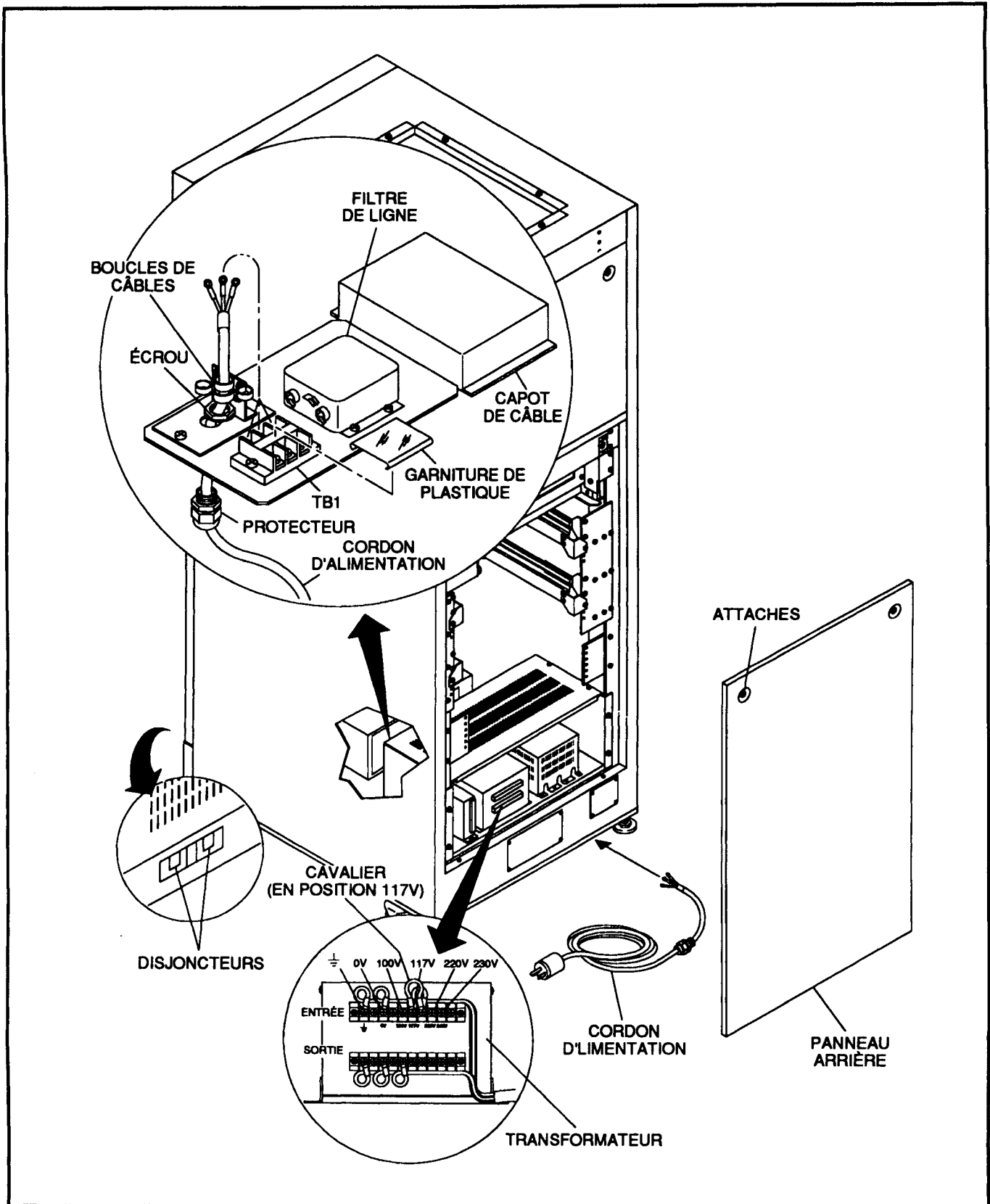

Figure 2-5. Sélection de la tension et alimentation du RSS-48b

**ATTENTION**

Le RSS-48b peut être endommagé de façon permanente s'il est mis sous tension avec le cavalier placé dans la mauvaise position.

4. Configurer chacune des unités de bande magnétique installées selon les mêmes caractéristiques de courant d'alimentation que celles du transformateur. Les instructions de configuration figurent dans la notice d'utilisation ou dans le manuel de l'opérateur fournis avec l'unité de bande magnétique.
5. Remonter le panneau arrière.

**2.7.2.3. Câble d'alimentation****AVERTISSEMENT**

Ne pas utiliser la fiche électrique à 117 VCA fournie pour faire fonctionner l'unité sur du courant à 100, 220 ou 230 VCA, ou hors des États-Unis ou du Canada.

Le câble d'alimentation fourni se branche comme indiqué ci-bas :

1. Vérifier que les deux interrupteurs du panneau avant sont en position hors tension (OFF).
2. Préparer le câble d'alimentation fourni comme suit (see Section 6 for cable/wall plug part numbers):
  - Pour utiliser le RSS-48b sur courant 117 VCA aux États-Unis et au Canada, se servir de la fiche déjà installée sur le câble d'alimentation. Pour une exploitation en 220 ou 230 V c.a. aux É.-U., remplacez la prise murale de 117 V c.a. par une prise murale approuvée, conforme aux normes UL/CSA.
  - Pour utilisation à l'extérieur du Canada et des États-Unis, installez une prise murale approuvée, conforme aux normes en vigueur dans le pays où le produit est installé, sur un câble harmonisé. Voir la figure 2-6 pour les renseignements de retrait des extrémités d'entrée et la figure 2-7 pour les normes relatives aux prises murales en vigueur dans divers pays. La section 6 contient des renseignements nécessaires pour commander des prises murales approuvées.
3. Démontez le panneau arrière inférieur en faisant pivoter les attaches pour amener la rainure en position horizontale, puis en tapant légèrement sur le coin supérieur avec le poing.

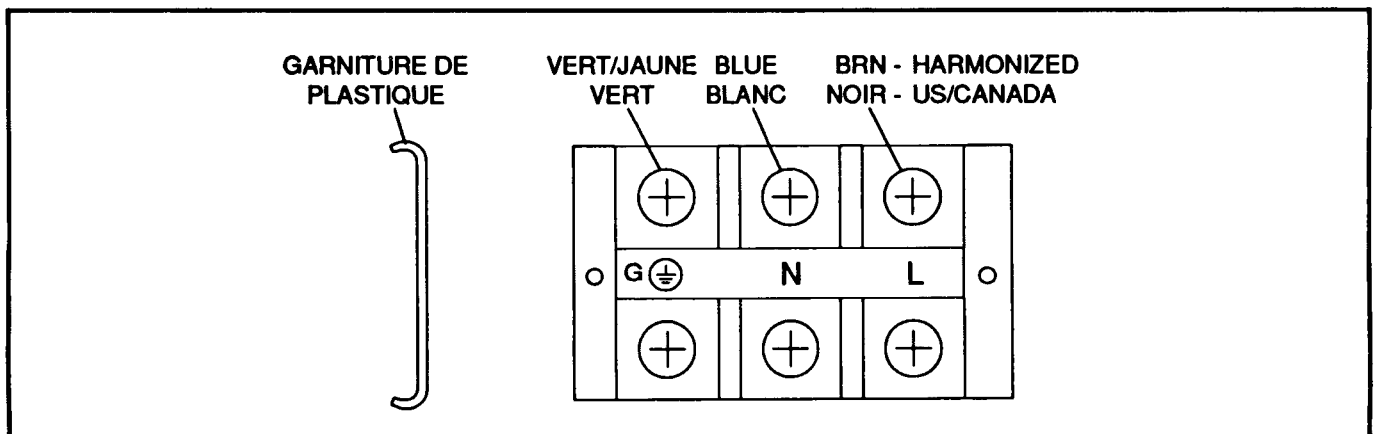

Figure 2-6. Arrivée de courant du RSS-48b

4. Insérez le cordon d'alimentation à l'aide d'un serre-câble dans l'ouverture d'accès se trouvant au bas de l'armoire et des boucles de câble, tel qu'indiqué. Les boucles de câble utilisées dépendent du diamètre extérieur du cordon d'alimentation (éloignez les boucles non utilisées du cordon).
5. Poussez le serre-câble à l'intérieur de l'ouverture du support et fixez solidement à l'aide d'un écrou. Resserrez les vis de maintien des boucles de câble.
6. Raccordez les extrémités du cordon d'alimentation à l'unité d'arrivée de l'alimentation TB1 tel qu'indiqué (voir figure 2-6). Remplacez les garnitures de plastique transparent.
7. Remonter le panneau arrière.

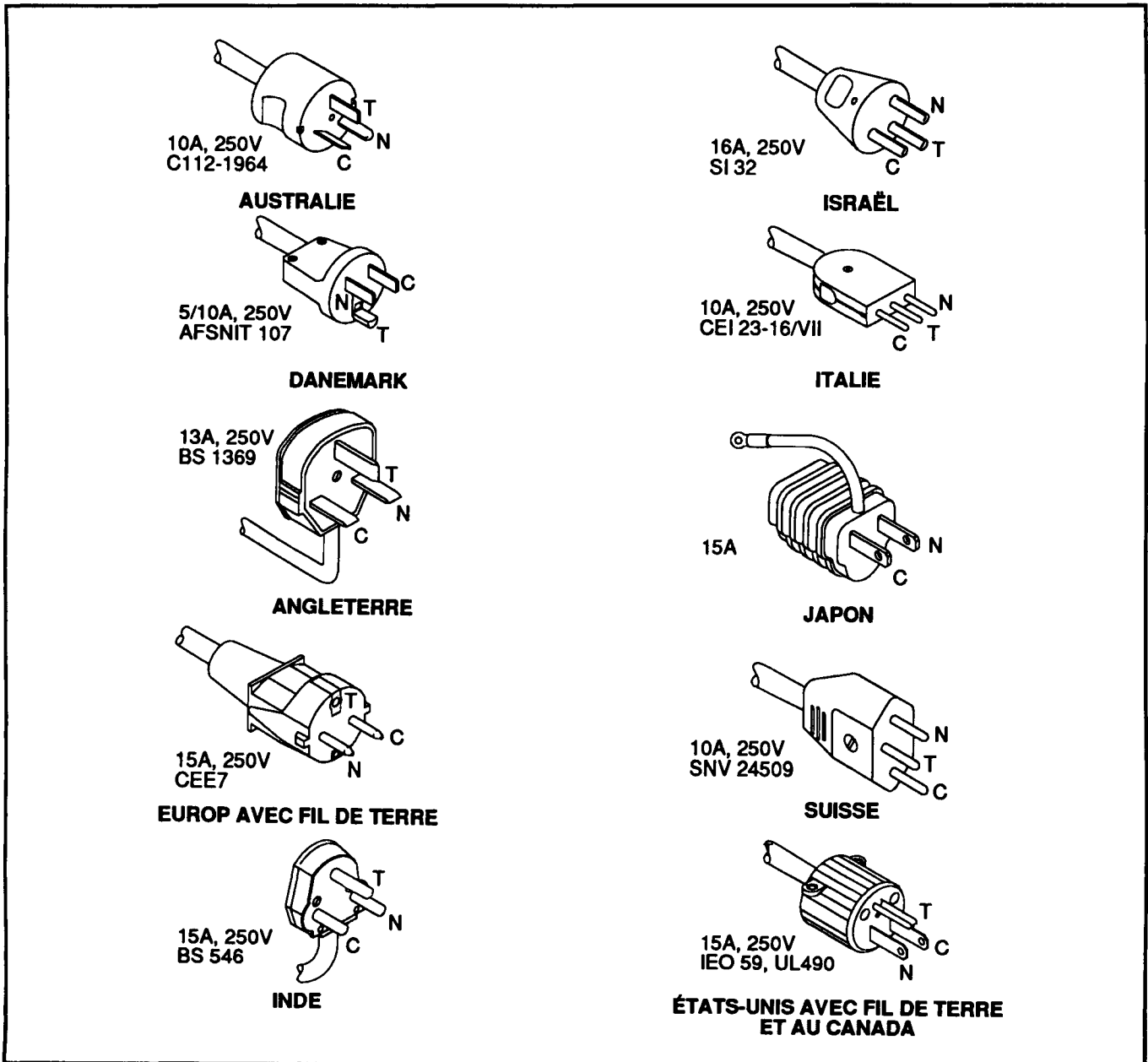

Figure 2-7. Types de fiches de câbles d'alimentation

## 2.7.3. DRIVE INSTALLATION

### WARNING

Verify that the power cable is unplugged prior to performing the drive installation procedure.

### WARNUNG

Vor der Installation des Laufwerks sicherstellen, daß das Netzkabel abgezogen ist.

### AVERTISSEMENT

Assurez-vous que le cordon d'alimentation est débranché avant de commencer à installer l'unité.

The RSS-48b is shipped from the factory with mounting brackets and slides specifically configured and adjusted for the RSP-2150 (2 max), or the VLDS (2 max) Tape Drive(s). RSS-48b configurations are as follows:

- Standard - configured for two RSP-2150 Tape Drives.
- Optional VLDS - configured for two VLDS Tape Drives.

### 2.7.3.1. RSP-2150 and VLDS

RSP-2150 and VLDS Tape Drive(s) are installed from the rear of the RSS-48b as follows (see Figure 2-8):

### WARNING

When less than two tape drives are installed, a blank drive panel must be installed in the unused drive location.

### WARNUNG

Wenn weniger als zwei Laufwerke installiert werden, muß im ungenutzten Laufwerkbereich eine Blindplatte installiert werden.

### AVERTISSEMENT

Lorsque vous installez moins de deux unités, vous devez aussi installer un panneau d'unité vierge dans le logement d'unité non utilisé..

**CAUTION**

All tape drives installed in the RSS-48b must comply with IEC 950 requirements.

**VORSICHT**

Alle in der RSS-48b installierten Bandgeräte müssen den IEC-950-Bedingungen entsprechen.

**ATTENTION**

Toutes les unités installées dans le RSS-48b doivent être en conformité avec les exigences IEC 950.

**NOTE**

If installing only one drive, always use the upper most location. The procedure that follows applies to both the upper and lower locations.

1. Remove the top and bottom rear panels by rotating the fasteners until the slot is horizontal then lightly rap the upper corner with the palm of your hand.
2. Remove the two M5 x 10 hex drive that secure the rail stops to the cabinet.
3. Remove the left side rail by pulling from the rear of the RSS-48b and pressing the rail catch. Attach the rail to the tape drive using eight 6-32 x  $\frac{3}{8}$  screws provided in the accessory kit. When attaching the rail to the side of the tape drive, the rail stop must be as shown in Figure 2-8.
4. Repeat step 3 for the right side rail.
5. Pull both slides from the rear of the RSS-48b until they lock (extended approximately 10 inches).

**WARNING**

A minimum of 2 persons are required to perform the next step.

**WARNUNG**

Mindestens 2 Personen sind zur Ausführung des nächsten Schrittes erforderlich.

**AVERTISSEMENT**

Il faut au minimum 2 personnes pour effectuer l'opération suivante.

6. Install the tape drive in the RSS-48b by matching the rail to the slides, then push the tape drive in the RSS-48b until the rail catch locks on the slide. Press in the rail catches on both sides and push the tape drive completely into the RSS-48b.
7. Install the two M5 x 10 hex drive screws that secure the rail stops to the cabinet.

**NOTE**

Because each RSS-48b is adjusted to match the model of the tape drive(s) installed before leaving the factory, mechanical adjustment is usually not necessary. If minor adjustments are necessary, they will be performed during the operational check later in this section.

8. The tape drive(s) are cabled as follows:
  - Attach the supplied power cable to the drive outlet.
  - Information about the interface cable(s) for the tape drive(s) are provided in the manual supplied with the tape drive. Cables are routed through the RSS-48b's floor access panel.
9. Replace the top and bottom rear panels.

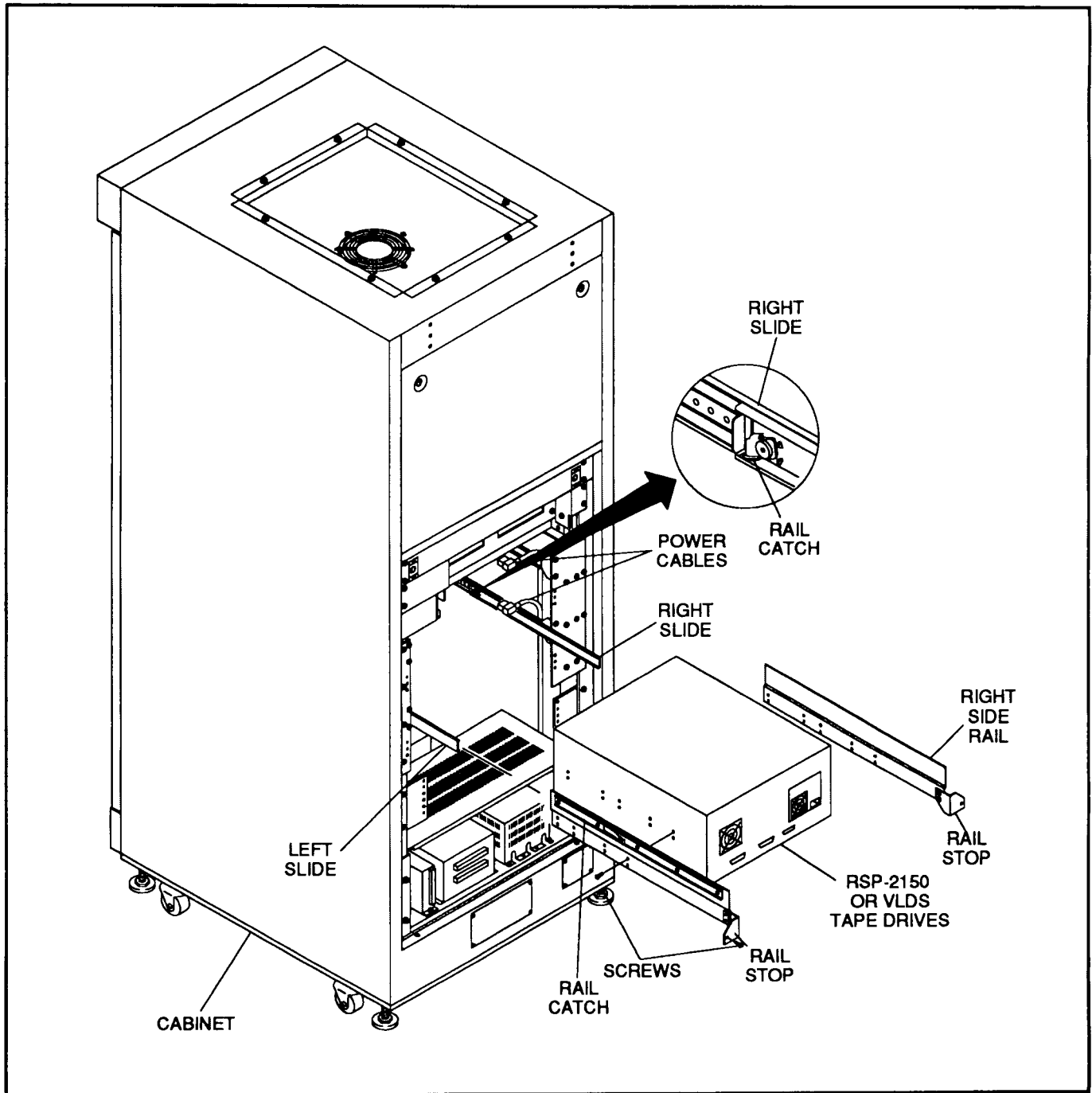

Figure 2-8. Tape Drive Installation

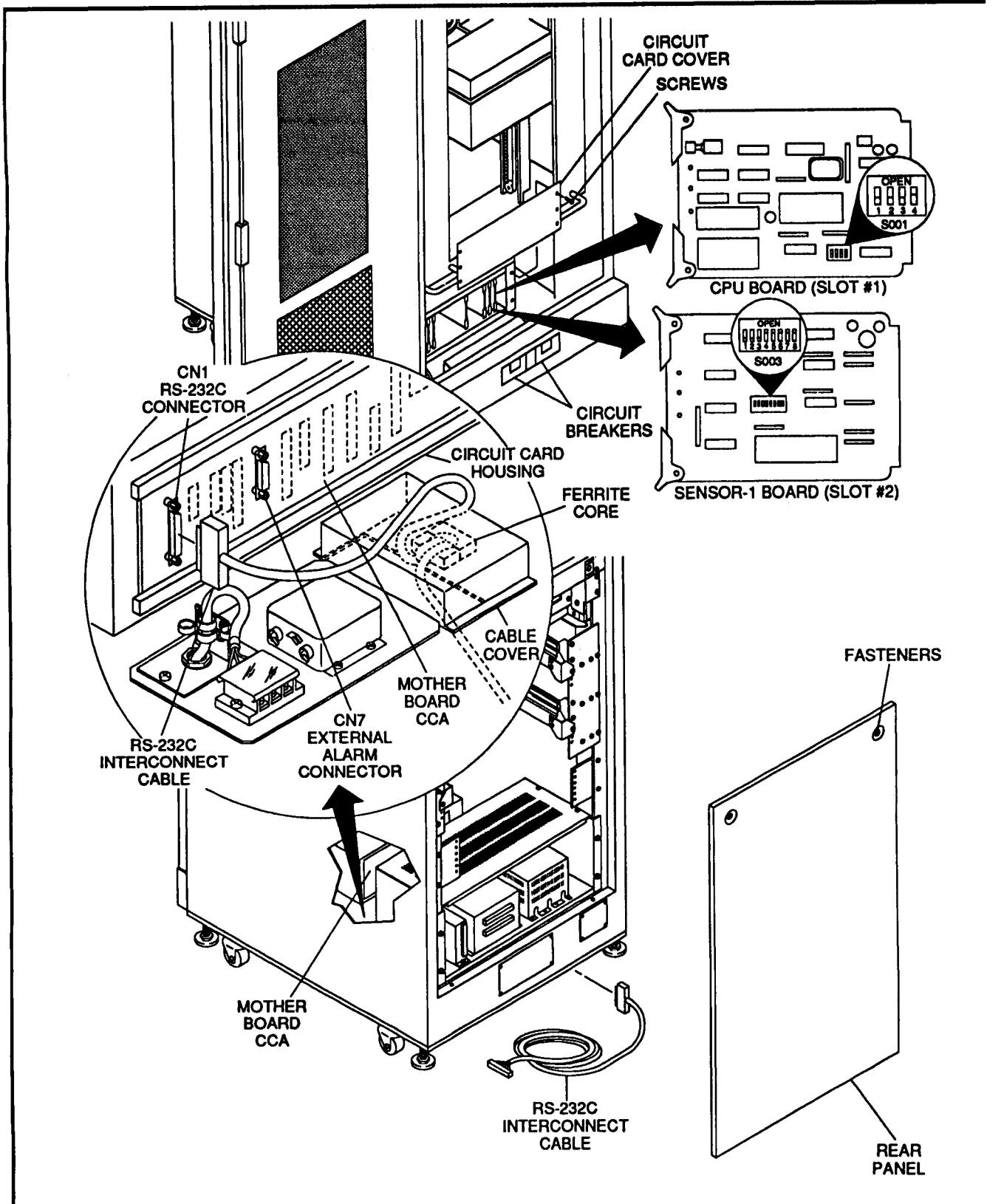

Figure 2-9. RSS-48b Communication Parameters

## 2.7.4. COMMUNICATION

**NOTE** The following description is adequate to connect to the RS-232C serial interface, and provides an understanding of the required interface signals. For more information on RS-232C, refer to EIA specification EIA-RS-232-C.

During remote operation, control and data signals from the controller are input and output from the RSS-48b via a full duplex asynchronous serial communication interface based on RS-232C (EIA-RS-232-C). The controller is connected to the RSS-48b using a standard "null modem" interconnect cable.

The interconnect cable assembly can be obtained from Metrum (see Section 6), or fabricated using the information found in paragraph 2.7.4.1.

Information required to connect the interconnect cable to the RSS-48b (paragraph 2.7.4.2) and set the RSS-48b's port parameters (paragraph 2.7.4.3) are also provided.

### 2.7.4.1 Interconnect Cable

The interconnect cable used to connect the controller to the RSS-48b is shown in Figure 2-10.

- The connector used to mate with the RSS-48b is a 25 pin male D-shell type connector.
- The connector used to mate with the controller serial port is typically either a 9 pin or 25 pin D-shell type connector.

**NOTE** If the controller serial port is not a 9-pin or 25-pin D-shell, use the information in the controller's User's Guide to determine where the signals in Figure 2-10 should be connected.

- Use 9-conductor, 100% double shield (foil-shield and braid) computer cable.
- Completed cable should not exceed 50 feet.

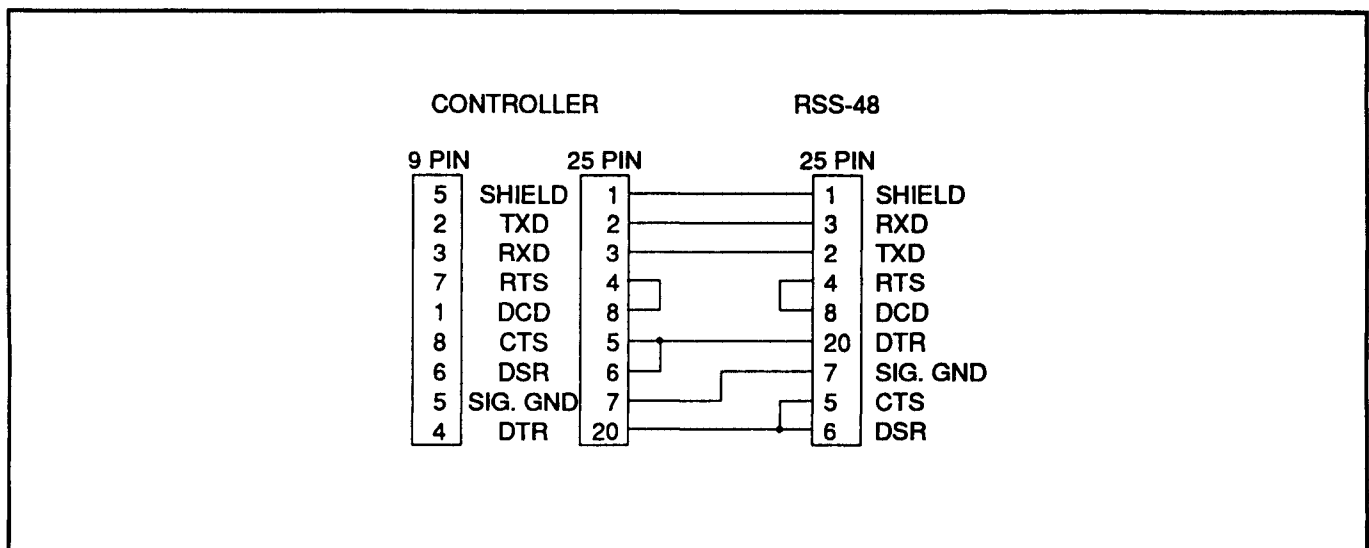

Figure 2-10. Interconnect Cable

## 2.7.4.2. RS-232C Cable Connection

The RS-232C interconnect cable is installed as follows:

1. Set the system and drive circuit breakers to off and unplug the power cable (if connected).
2. Remove the bottom rear panel by rotating the fasteners until the slot is horizontal then lightly rap the upper corner with the palm of your hand.
3. Feed the interconnect cable through the cable cover on the floor of the RSS-48b and connect to the RS-232C connector (CN001) on the motherboard (see Figure 2-9).
4. Wrap the interconnect cable two turns through a ferrite core halves as close to the cable cover opening as possible. Use supplied tape to secure core halves.
5. Connect the other end of the cable to the controller.
6. Replace the rear panel.

## 2.7.4.3. Communication Parameters

Prior to remote operation, parameters such as baud rate, parity, and start/stop bits must be set to match the communication program used by the controller. This configures how serial data is sent and received to/from the RSS-48b and the controller.

Serial data format consists of up to 11 bits. Frame construction is dependent on how the communication parameters are configured (refer to Section 2). Figure 2-11 shows the serial data format for the possible communication parameters.

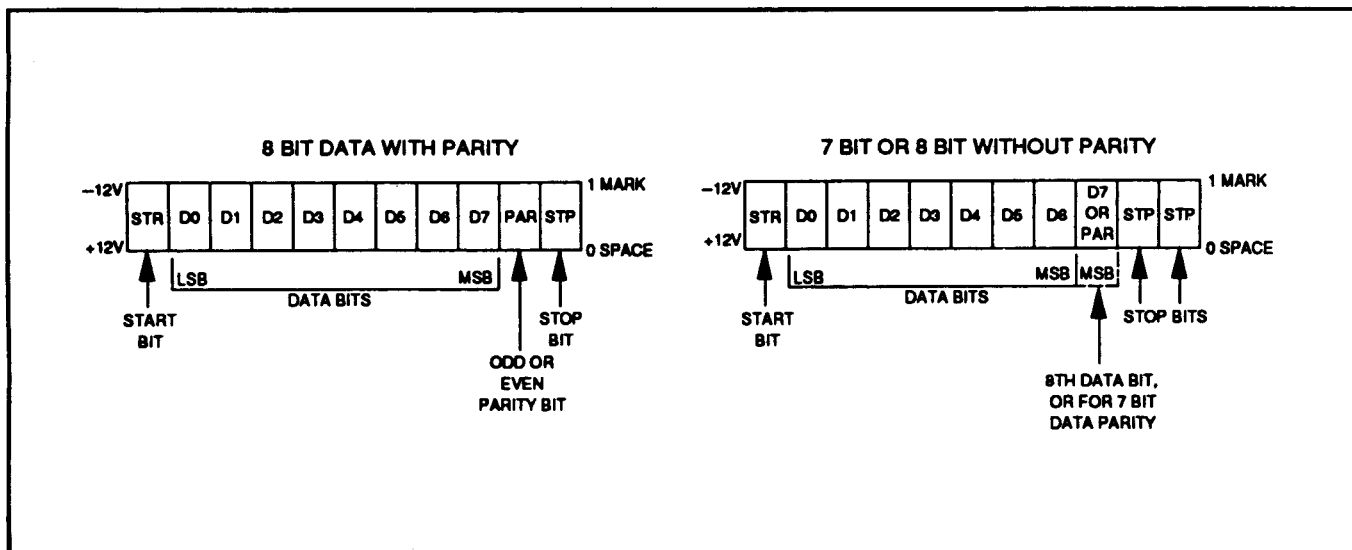

Figure 2-11. Serial Data Format

Communication parameters are selected in the RSS-48b using dip switch settings on the CPU Circuit Card Assembly (CCA) in slot#1 and the Sensor-1 CCA in slot#2.

1. Set the system and drive circuit breakers to off and unplug the power cable (if connected).
2. Open the front door, and locate the card cage.
3. Remove the circuit card cover (six screws).

**CAUTION**

The CCA's in the RSS-48b contain ESDS devices. Proper ESDS device handling procedures must be followed. Refer to the ESDS DEVICE HANDLING information at front of this manual.

- Remove the CPU CCA in slot#1 and lay component side up on an antistatic surface. Locate S001 (refer to Figure 2-9) and set positions 1-3 (baud rate) as follows.

Baud Rate	1	2	3	4
300	O	C	O	C
1200	C	O	O	C
2400	O	O	O	C
Where O=Open, C=Closed				

**NOTE** Position 4 (termination character for command strings) must be set closed (>).

- Replace the CPU CCA in slot#1.
- Remove the Sensor-1 CCA in slot#2 and lay component side up on an antistatic surface. Locate S003 (refer to Figure 2-9) and set positions 1-2 (parity) as follows.

**NOTE** S003 positions 4 through 8 are not used.

Parity	1	2	3	4	5	6	7	8
None	X	C	X	X	X	X	X	X
Odd	C	O	X	X	X	X	X	X
Even	O	O	X	X	X	X	X	X
Where O=Open, C=Closed, X=Don't Care								

- Set position 3 (data bit length) as follows.

Data Bit	1	2	3	4	5	6	7	8
7-bit	X	X	O	X	X	X	X	X
8-bit	X	X	C	X	X	X	X	X
Where O=Open, C=Closed, X=Don't Care								

**NOTE** Stop bit is dependent on the parity and data bit length as follows:

- When data bit length is set to 8 AND parity is odd or even, then stop bits=1.
- For all other settings, stop bits=2.

- Replace the Sensor-1 CCA in slot#2.
- Replace the circuit card cover (six screws).
- Close the front door.

#### 2.7.4.4. Serial Interface Signals

There are eight RS-232C signals used during remote operation. A description of each is provided below. Refer to EIA specification 232-D for further information.

**NOTE** Unless otherwise specified, positive logic is used on all signals.

- **TxD (Transmit Data):** Output serial data (status, etc) from the RSS-48b to the controller is negative logic except for the start bit.
- **RxD (Receive Data):** Input serial data (commands, etc) from the controller to the RSS-48b must be negative logic except for the start bit.
- **RTS (Request To Send):** Output goes to "1" (+12V) when the RSS-48b is ready to receive data, and "0" (-12V) when the RSS-48b is not ready to receive data.
- **CTS (Clear To Send):** The RSS-48b will start transmitting data when this pin is "1" (+12V). Once initiated, the transmission continues until the last character is sent. This is a required input.
- **DCD (Data Carrier Detect):** Not used.
- **DSR (Data Set Ready):** Not used.
- **DTR (Data Terminal Ready):** Output is always "1" (+12V).
- **SIG GND:** Signal Ground.
- **Shield:** Protective ground.

#### 2.7.5. ALARMS

The RSS-48b has a total of three alarm signals. Alarm number 1 is the system alarm. Alarms 2 and 3 are available for operator use. During operation, these are the alarms that are sounded to alert the operator of a problem or condition that requires operator intervention. Alarms 1 through 3 also provide individual output voltages at CN007 (15-pin connector) on the motherboard (refer to Figure 2-9 for location).

110 Vac at 0.5A or 24 Vdc at 1A is available for use by external devices during alarm conditions at the following pin numbers of CN007:

- Alarm 1 – pins 1 and 9.
- Alarm 2 – pins 2 and 10.
- Alarm 3 – pins 3 and 11.

**NOTE** Alarms can be reset (individually or all at once) using the front panel control or by sending a command over the RS-232C serial interface. See Sections 3 and 4 for more information.

## 2.8. INITIAL TURN-ON

The following instructions are provided to power-up and check the overall operation of the RSS-48b for the first time. Also, minor mechanical adjustments are also performed if necessary.

**NOTE** See Installation Troubleshooting (paragraph 2.9) if problems are encountered with the initial turn-on procedures.

### 2.8.1. INITIAL POWER-UP

Procedures to power-up the RSS-48b for the first time are as follows (see Figure 2-12):

1. Prior to plugging in the RSS-48b, verify that:
  - the site chosen meets or exceeds the requirements described in paragraph 2-4.
  - the RSS-48b has been placed and leveled, and that all internal and external packing material and restraining devices have been removed using the instructions provided in paragraphs 2.5 and 2.6.
  - the RSS-48b has been installed (w/tape drives), cabled and configured (both power and communication) using the instructions provided in paragraph 2.7.2.
2. Set both the front panel system and drive circuit breakers to OFF.
3. Open the front door, and perform a visual inspection of the inside of the RSS-48b to ensure that there are no foreign objects present. If data cartridges are installed in the rotary storage drum, verify that all are not protruding from the face of the drum.
4. Physically move the the Elevator Assembly (up/down) and the Handler Assembly (in/out) to verify a full range of free movement.
5. Plug the RSS-48b power cable into the proper power source.
6. Set the installed tape drive(s) power switches to the ON position. Power-up instructions are provided in the User's Guide or Operator's Manual supplied with the tape drive.

**NOTE** Tape drives will not power-up until the front panel drive circuit breaker is set to ON.

7. Set the front panel drive circuit breaker to ON. Verify each tape drive performs a successful power-up.
8. Close the front door.
9. Set the front panel system circuit breaker to ON. Verify that:
  - the rotary storage drum rotates CW to the next face position.
  - the Handler moves to the full out or middle position (whichever is closest).
  - the Elevator moves to the closest bin number or tape drive position.

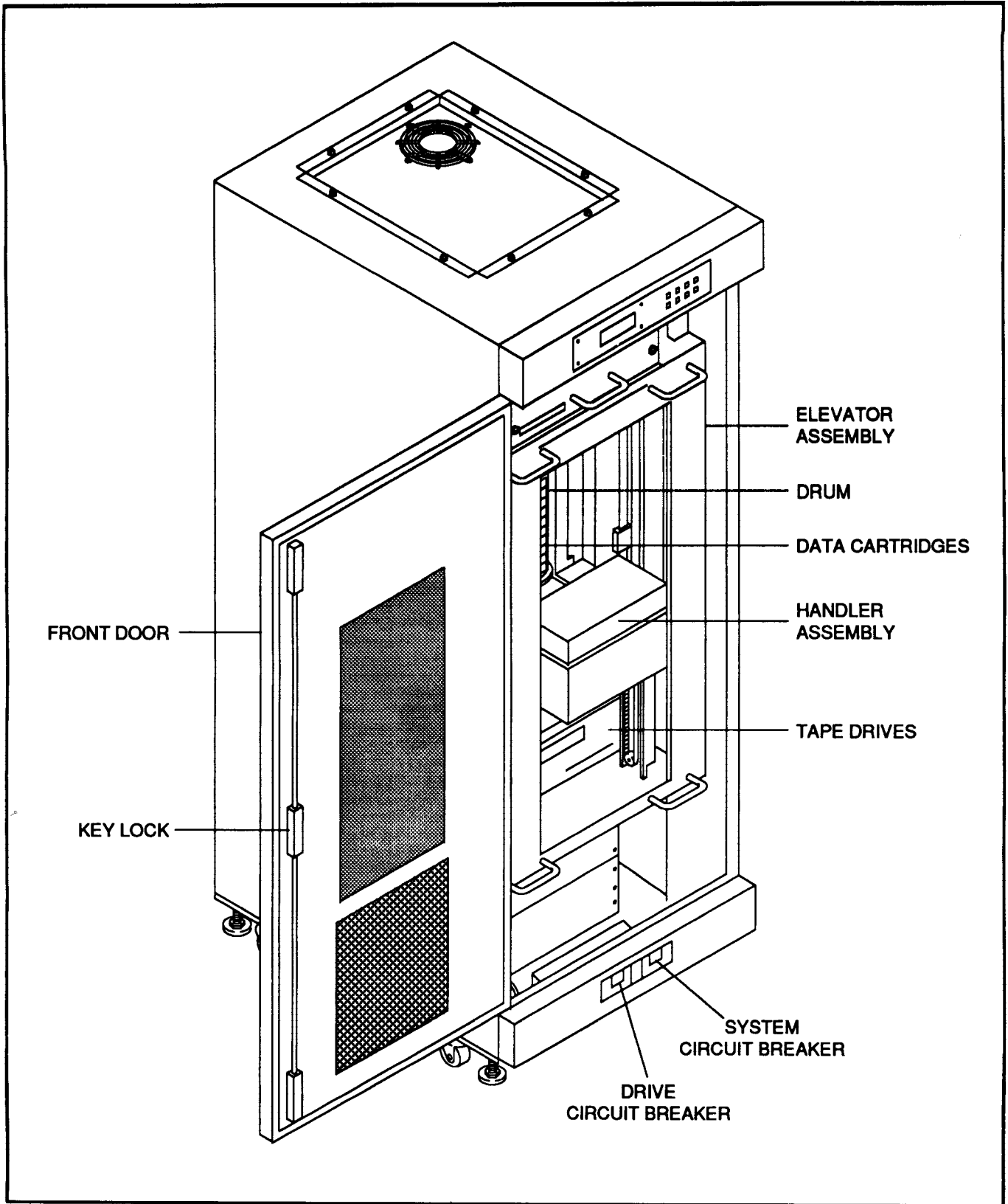

Figure 2-12. RSS-48b Initial Turn-on

## 2.8.2. OPERATIONAL CHECK AND ADJUSTMENT

Prior to operating the RSS-48b, adjust the installed tape drive(s) height and depth as follows:

1. Set the front panel drive circuit breaker to off.
2. Open the front door and insert a data cartridge into the tape drive being adjusted. Because the drive is off, the cartridge can only be inserted part way. Just insert the cartridge until flush against the internal stop.

### WARNING

The next steps must be completed by Metrum Trained personnel only, because they must be performed with power applied to the RSS-48b and the front door open. Both electrical shock hazard and mechanical hazard from moving parts exist when operating the RSS-48b with the door open. Take necessary precautions to protect yourself from both hazards during the remainder of this procedure.

### WARNUNG

Da die nächsten Schritte bei geöffneter Vordertür und eingeschalteter Stromzufuhr der RSS-48b erfolgen, dürfen sie nur von Personal durchgeführt werden, das von Metrum geschult wurde. Beim Betrieb der RSS-48b bei geöffneter Tür besteht das Risiko eines elektrischen Schlags und Verletzungsgefahr durch bewegliche mechanische Teile. Zum Schutz vor beiden Gefahren während dieses Verfahrens alle erforderlichen Vorsichtsmaßnahmen ergreifen.

### AVERTISSEMENT

Les étapes suivantes doivent être effectuées par du personnel formé par Metrum seulement, car elles doivent être effectuées pendant que le RSS-48b est sous tension et que la porte avant est ouverte. La manipulation de pièces pendant l'exploitation du RSS-48b avec la porte ouverte présente toujours un risque de choc électrique et un danger mécanique. Prenez les précautions nécessaires pour vous protéger contre ces deux dangers pendant le reste de la procédure.

3. Locate the interlock switch on the upper right side of the RSS-48b (see Figure 2-13), remove the access cover, and pull the plunger to the full out position (interlock defeated).
4. Use the DOWN button to position the handler at the data cartridge in the tape drive.
5. Press the EJECT button and verify that the handler grabs the data cartridge JUST as the leaf spring touches the back of the cartridge as shown in Figure 2-13.
  - If incorrect, drive depth is adjusted by removing the lower rear panel and SLIGHTLY adjusting the tape drive's rail stops (two M4 cap head screws on each stop) to position the tape drive more in or out. Repeat step until correct.

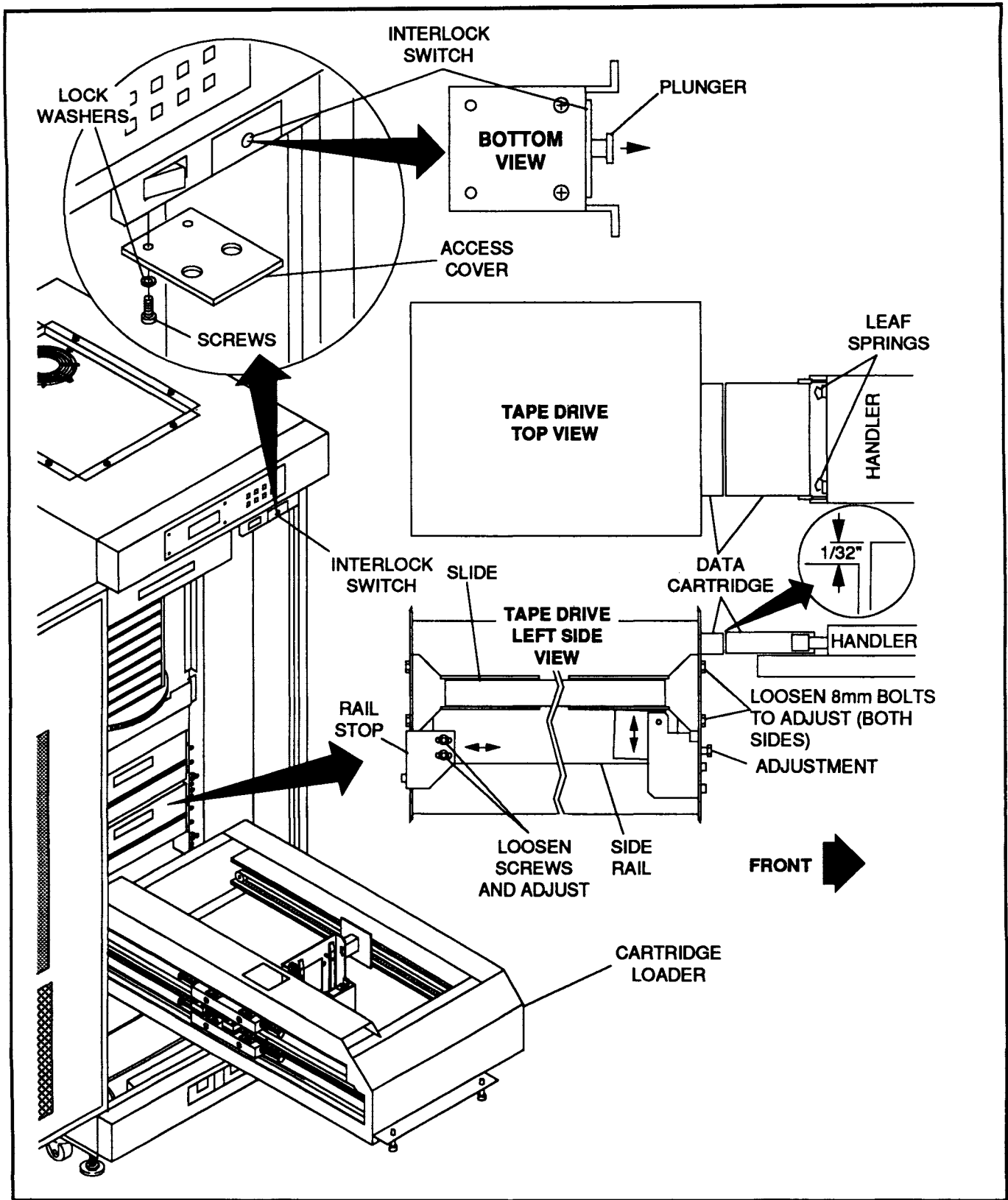

Figure 2-13. RSS-48b Initial Check and Adjustments

6. Leave the data cartridge installed in the tape drive as in step 2. Use the UP/DOWN/EJECT buttons to grasp the data cartridge installed in bin A 12.
7. Use the DOWN button to position the handler w/data cartridge until it is even with the data cartridge in the tape drive. Proper alignment is when the data cartridge in the handler is slightly higher (1/32 inch) than the data cartridge installed in the tape drive and when both sides are even (refer to Figure 2-13).
  - If incorrect, drive adjustment is required. Note direction and distance that drive needs to be adjusted.

**WARNING**

A minimum of 2 persons are required to perform the next step. If the Cartridge Loader Assembly is allowed to drop uncontrolled, serious bodily injury and/or equipment damage may result.

**WARNUNG**

Mindestens 2 Personen sind zur Ausführung des nächsten Schrittes erforderlich. Wenn die Patronenladeeinheit unkontrolliert fallen gelassen wird, kann das zu ernsthafter Körperverletzung bzw. Geräteschaden führen.

**AVERTISSEMENT**

Il faut au minimum 2 personnes pour effectuer l'opération suivante. Si on laisse tomber l'ensemble de chargeur à cartouche, on s'expose à des blessures et/ou à des dégâts matériels graves.

Loosen the two knurled fastening screws and lower the Cartridge Loader Assembly to the floor. While lowering the Cartridge Loader Assembly, make sure the cable harness on the lower left corner is free.

Loosen the four 8 mm bolts holding the drive's left and right rack slides.

Rotate both adjustment screws (CW raises drive, CCW lowers the drive) until the drive is at the correct height.

Raise the Cartridge Loader Assembly and tighten the two knurled fastening screws.

Verify alignment is correct. Repeat step until correct alignment is achieved.

**NOTE** The remaining procedures check basic functions to verify proper alignment.

8. Open the front door and insert a data cartridge (with bar code label) into bin A 01. Close the front door.
9. Power-up the RSS-48b using the instructions provided in paragraph 2-8.

10. Using the RSS-48b's front panel, perform the following actions:
  - [ ] press the LEFT button once and verify the rotary storage drum moves one face to the left.
  - [ ] press the RIGHT button once and verify the rotary storage drum moves back one face to the right.
  - [ ] press the UP button once and verify the handler assembly moves up one bin number (unless at 01 already) or tape drive position.
  - [ ] press the DOWN button once and verify the handler assembly moves down one bin number or tape drive position (unless at the bottom drive already).
  - [ ] use the UP/DOWN and RIGHT/LEFT buttons until the handler is positioned at the data cartridge in bin A 01.
  - [ ] press the BAR CODE READ button and verify the bar code is shown on the front panel display.
  - [ ] press the EJECT button and verify the handler grabs the data cartridge.
  - [ ] press the DOWN button until the handler is positioned at the installed tape drive.
  - [ ] press the INJECT button and verify the handler pushes the data cartridge into the tape drive, and that the tape drive loads the cartridge.
  - [ ] open the front door and manually eject the data cartridge from the tape drive. Close the front door.
  - [ ] with the handler positioned at the ejected data cartridge in the tape drive, press the EJECT button and verify the handler grabs the data cartridge.
  - [ ] press the UP button until the handler is positioned at bin A 12.
  - [ ] press the INJECT button and verify the handler pushes the data cartridge into the rotary storage drum bin.
11. Analyze the results of the operational check.
  - If the check performed without problem, the RSS-48b is ready for operation. See Section 3 for information.
  - Any problems indicate the RSS-48b requires service. See Section 5 for more information on locating the malfunction before proceeding with operation.
12. Replace switch cover.

## 2.9. INSTALLATION TROUBLESHOOTING

Use the following procedures to assist you in determining the location of problems encountered in getting the RSS-48b on line and performing basic functions.

1. Verify that the RSS-48b is properly connected to facility power.
2. Verify that front panel drive circuit breaker is set to ON.
3. Are the tape drives running?
  - If not, set the system and drive circuit breakers to OFF and check the ac facility power to ensure that the proper voltage is being applied to the RSS-48b. Also check that the installed tape drive(s) are switched to ON, are configured to operate on the ac facility power available, are connected to the power cables on the rear of the RSS-48b, and that the fuses installed are the correct size and not electrically open. Instructions are provided in the User's Guide or Operator's Manual supplied with the tape drive.
4. Verify that front panel system circuit breaker is set to ON.
5. Are the cooling fans running?
  - If not, set the system and drive circuit breakers to OFF and check: the ac facility power to ensure that the proper voltage is being applied to the RSS-48b, that the power transformer voltage selector jumper is set to the correct setting.
6. Does the RSS-48b complete the operational check?
  - If not, perform as instructed.
7. For all other failures, see the instructions provided in Section 5.



# 3. OPERATION

---

## 3.1. GENERAL

This section provides operating information for the RSS-48b. The RSS-48b requires very little direct physical operator contact during normal operation, as all functions are normally accessed using the controller. After installation (described in Section 2) and loading the RSS-48b with up to 48 data cartridges (described later), local operator functions primarily consist of turning power on or off, and performing operator's preventive maintenance.

Command syntax used during remote operation over the RS-232C serial interface is also provided later in this section.

## 3.2. RSS-48b FRONT AND REAR PANEL FEATURES

The paragraphs that follow explain the function of the RSS-48b front and rear panel connectors, controls, and indicators. Refer to Figure 3-1 for item locations.

**A Key Lock:** Ace® type lock used to open the front door.

### WARNING

Do not operate the RSS-48b with the front door open. Both electrical shock hazard and mechanical hazard from moving parts exist when operating the RSS-48b with the door open.

### WARNUNG

Die RSS-48b nicht bei geöffneter Fronttür betreiben. Sowohl die Gefahr eines elektrischen Schlags als auch die Gefahr durch sich bewegende Teile besteht, wenn die RSS-48b bei offener Tür betrieben wird.

### AVERTISSEMENT

Ne pas utiliser le RSS-48b quand le panneau avant est ouvert. Il existe des dangers d'électrocution et des risques de blessures provenant de pièces mécaniques en mouvement lorsqu'on utilise le RSS-48b avec le panneau avant ouvert.

- B Front Door:** Provides access to the assemblies and components housed inside the RSS-48b. Window allows viewing of internal workings. Also contains the air filter element. Door can only be opened using the ACE® key provided.
- C Cartridge Loader Retaining Screws:** Two knurled captive screws and two hex drive screws that lock the Cartridge Loader Assembly in the closed position.
- D Operational Panel:** Contains eight pushbuttons and a florescent display used during local operation. See Figure 3-2 for additional information.

**E Cooling Fan Exhaust Port:** Single fan pulls heated air out of the RSS-48b cabinet. This port must be kept clean and unobstructed during operation.

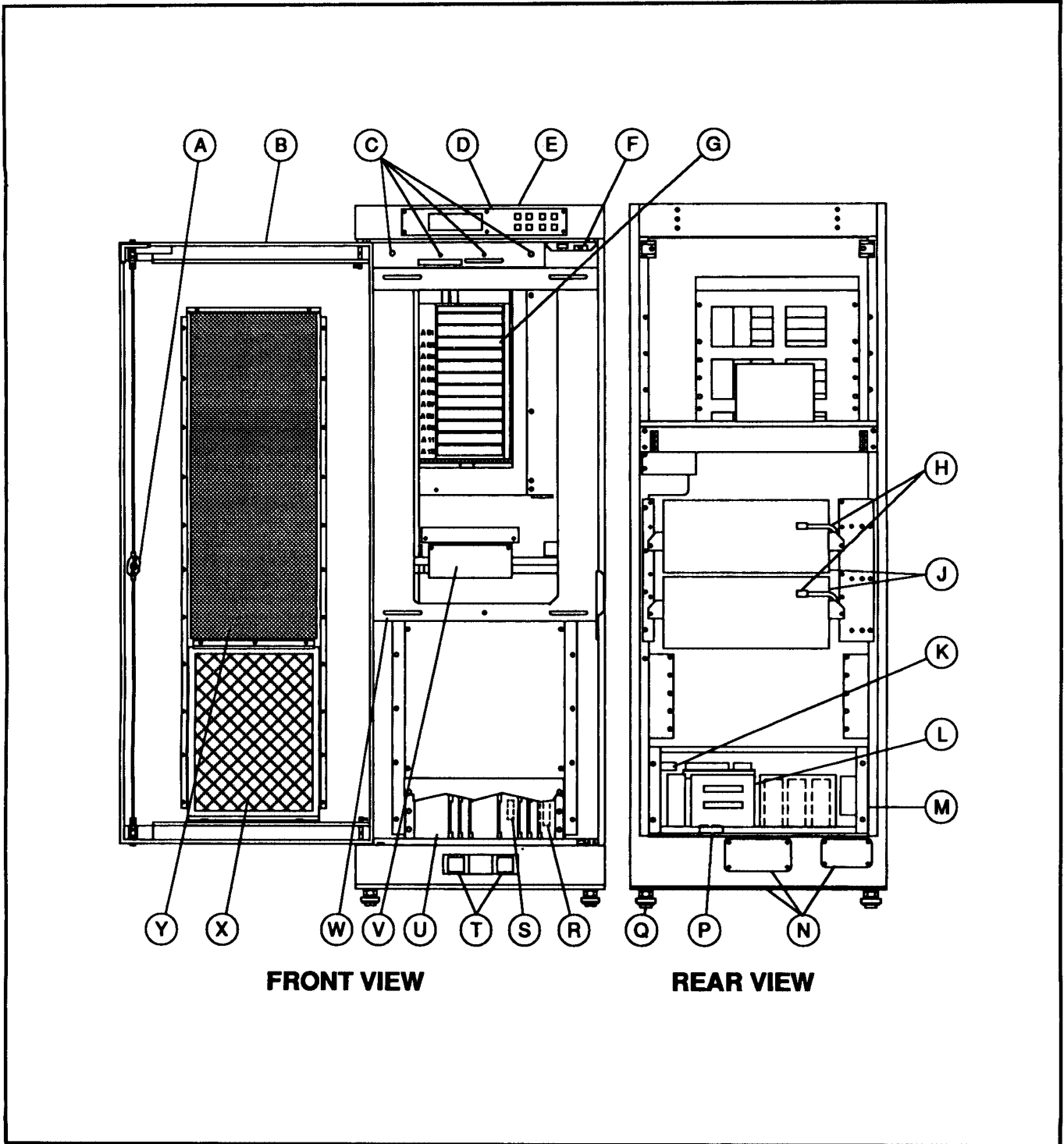

Figure 3-1. RSS-48b Front and Rear Panel Features

- F Interlock:** Three position switch senses the status of the front door. During normal operation, switch is either closed or open. When the plunger is pulled out, the interlock is defeated allowing operation with the front door open.

**WARNING**

Do not operate the RSS-48b with the front door open. Both electrical shock hazard and mechanical hazard from moving parts exist when operating the RSS-48b with the door open.

**WARNUNG**

Die RSS-48b nicht bei geöffneter Fronttür betreiben. Sowohl die Gefahr eines elektrischen Schlags als auch die Gefahr durch sich bewegende Teile besteht, wenn die RSS-48b bei offener Tür betrieben wird.

**AVERTISSEMENT**

Ne pas utiliser le RSS-48b quand le panneau avant est ouvert. Il existe des dangers d'électrocution et des risques de blessures provenant de pièces mécaniques en mouvement lorsqu'on utilise le RSS-48b avec le panneau avant ouvert.

- G Rotary Storage Drum:** Stores up to 48 data cartridges. The drum rotates to one of four faces (A-D) allowing access to each of the 12 bins by the Handler Assembly. Precise position is determined using sensors located on the top of the drum.
- H Tape Drive Power Cables:** Two AC power cables terminated with female CEE 22 connectors used to connect up to two installed tape drives or accessories. Power is only applied to these cables when the front panel drive circuit breaker is ON.
- J Tape Drive(s) (supplied separately):** Allows installation of two RSP-2150 or VLDS tape drives. Each drive is mounted from the rear on a rack slide. Refer to Section 2 for more information on installing tape drives.
- K Terminal Strip TB2:** A four position 3-wire power strip provides AC power to the tape drives and/or controller. Tape drive cables are connected at the factory. Controller power cables (not supplied) need to be connected by the user (if required).
- L Power Transformer:** Transforms the various input line voltages to a standard 100 Vac for the power supplies and drive motors (elevator, and rotary storage drum). Also contains the line voltage selection jumper.
- M Power Chassis:** Contains the terminal strips, power transformer, filters, power supplies, and motor drivers used during RSS-48b operation.
- N Access Panels:** Three removable panels (two on the rear panel, one on the floor) used to route communication, power, and serial interface cables to/from the inside of the RSS-48b. Refer to Section 2 of this manual for more information on cabling.
- P AC Input Terminal Strip TB1:** Used to apply AC power to the RSS-48b AC power supply using a removable AC power cord (supplied). Refer to Section 2 of this manual for more information on power cabling.

- Q Rollers/Leveling Pad:** Four caster type rollers are used to position the RSS-48b. Once in position, leveling pads are lowered to provide a stable and level installation. Refer to Section 2 of this manual for more information on positioning and leveling.
- R RS-232C Serial Interface Connector:** 25-pin female connector used for both control and data interchange between the controller and the RSS-48b. Refer to Section 2 of this manual for additional information on serial interface cabling.
- S External Alarm Connector:** 15-pin female connector used to notify external devices of an alarm condition. Refer to Section 2 of this manual for additional information on alarm cabling.
- T Circuit Breakers:** Two separate 20 amp circuit breakers used to apply power to the RSS-48b. The drive breaker applies power to the tape drive power cables, while the system breaker applies power to the remainder of the RSS-48b.
- U Card Cage:** Houses the control electronics in the RSS-48b. Includes seven removable Circuit Card Assemblies (CCA's) and one interconnecting motherboard.
- V Handler Assembly:** Used to inject and eject data cartridges from the rotary storage drum and installed tape drive(s). Also contains the circuitry to read the bar code data.
- W Cartridge Loader Assembly:** Physically houses the Handler and Elevator assemblies that provides the Z-axis (in/out) and Y-axis (up/down) movement of data cartridges. Cartridge Loader Assembly can be lowered to access the installed tape drive adjustment screws and shipping brackets by loosening the retaining screws.

**WARNING**

A minimum of 2 persons are required to lower the Cartridge Loader Assembly. If it is allowed to drop uncontrolled, serious bodily injury and/or equipment damage may result.

**WARNUNG**

Zur Installation der Ladevorrichtung für die Kartuschen sind zwei Personen erforderlich. Wenn sie fallengelassen wird, können schwere Verletzungen bzw. Beschädigungen am Gerät auftreten.

**AVERTISSEMENT**

Il faut au moins deux personnes pour abaisser l'unité de chargement de cartouche. Si cette unité tombe sans être retenue, des blessures corporelles graves et/ou des dommages matériels pourraient en résulter.

- X Air Filter Element:** Removable filter used to cleanse cooling air before entering the RSS-48b.
- Y EMI Shield:** Used to reduce radiated emissions from the RSS-48b.

### 3.2.1. OPERATIONAL PANEL

The paragraphs that follow explain the function of the front operational panel controls, and indicators. Refer to Figure 3-2 for item locations.

**NOTE** When a button is green, it indicates that operation has been disabled by the RS-232C serial interface.

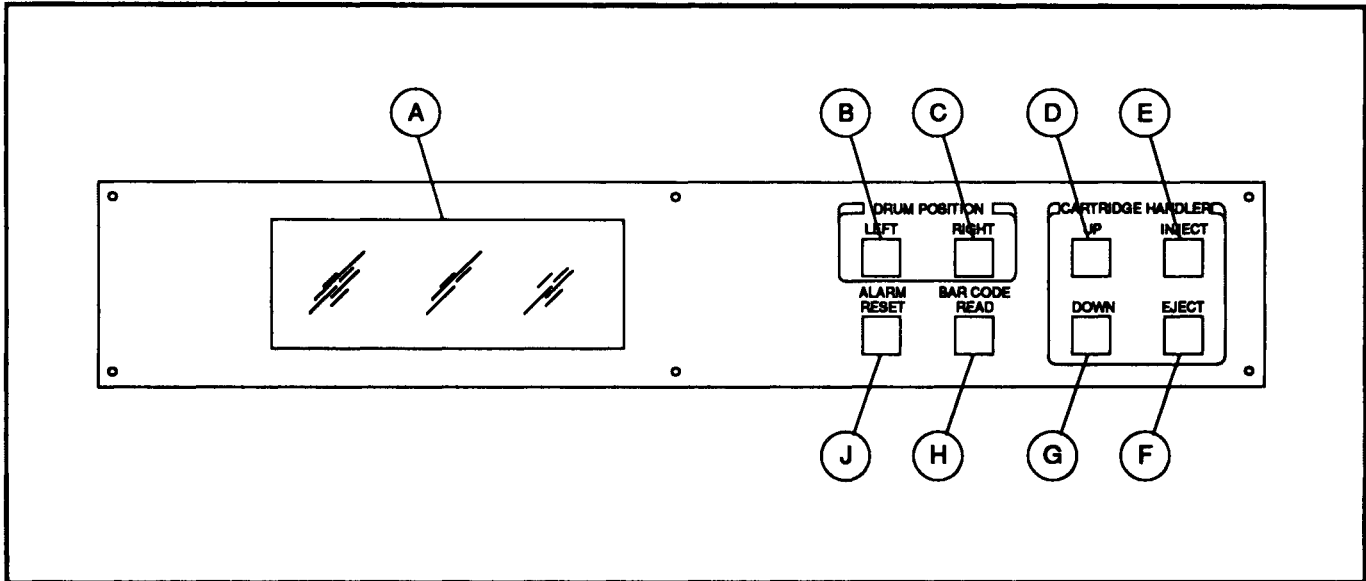

Figure 3-2. RSS-48b Operational Panel Features

- A Display:** 256 X 64 character florescent display shows bar code reader data, drive configurations, and the user defined character strings sent via the RS-232C serial interface.
- B Left Drum Position Button:** Press to rotate the rotary storage drum CCW 90° to the next face.
- C Right Drum Position Button:** Press to rotate the rotary storage drum CW 90° to the previous face.
- D Up Cartridge Handler Button:** Press to move the Handler Assembly one position (bin or tape drive) higher. Action is ignored if the handler is at the top most position.
- E Inject Cartridge Handler Button:** Press to insert the data cartridge currently loaded in the Handler Assembly (using the EJECT button) into the tape drive or bin directly in front of the handler. Action is ignored if the handler is not located at a bin position or tape drive, or if a data cartridge is not in the handler.

**NOTE** When inserting the data cartridge into a tape drive, verify that power is applied and that another data cartridge is not currently loaded. When inserting the data cartridge into a rotary storage drum bin, verify that another data cartridge is not currently loaded.

**F Eject Cartridge Handler Button:** Press to grasp the data cartridge directly in front of the handler (in a tape drive or bin). Action is ignored if a data cartridge is currently loaded in the handler.

**NOTE** An alarm signal will occur if a data cartridge is not located in front of the handler. Press Alarm Reset button to turn off alarm.

**G Down Cartridge Handler Button:** Press to move the Handler Assembly one position (bin or tape drive) lower. Action is ignored if the handler is at the bottom most position.

**H Bar Code Read Button:** Press to read the bar code label on the data cartridge located directly in front of the handler (in a tape drive or bin). Read result is displayed on the display. "\*\*\*\*\*" is shown on the display if a data cartridge is not present, or if the bar code was not detected.

**NOTE** The greatest cause of bar code read failures is foreign matter on the bar code label.

**J Alarm Reset Button:** Button lights to indicate that a system error has occurred, or the Alarm On command has been sent over the RS-232C serial interface. Press to reset the alarm condition. Pressing this button also clears a bar code data currently on the display.

### 3.3. TAPE DRIVE FEATURES

Features for the user supplied tape drives can be found in the Operator's Manual or User's Guide provided with the tape drive.

### 3.4. DATA CARTRIDGES

Data is stored on up to 48 one-half inch data cartridges installed in the RSS-48b. Each data cartridge is identified using a unique bar code label. Bar code labels must be affixed to each data cartridge prior to loading them in the rotating storage drum.

#### 3.4.1. BAR CODE LABEL

The bar code reader recognizes the following types of bar codes.

- Code 39 (3 of 9 code).
- Interleaved 2 of 5 code.
- UPC/EAN/JAN codes.
- Standard Codabar (NW7).
- Code 128.

**NOTE** The bar code reader may have difficulty reading dirty or damaged bar code labels. Clean or replace labels as required.

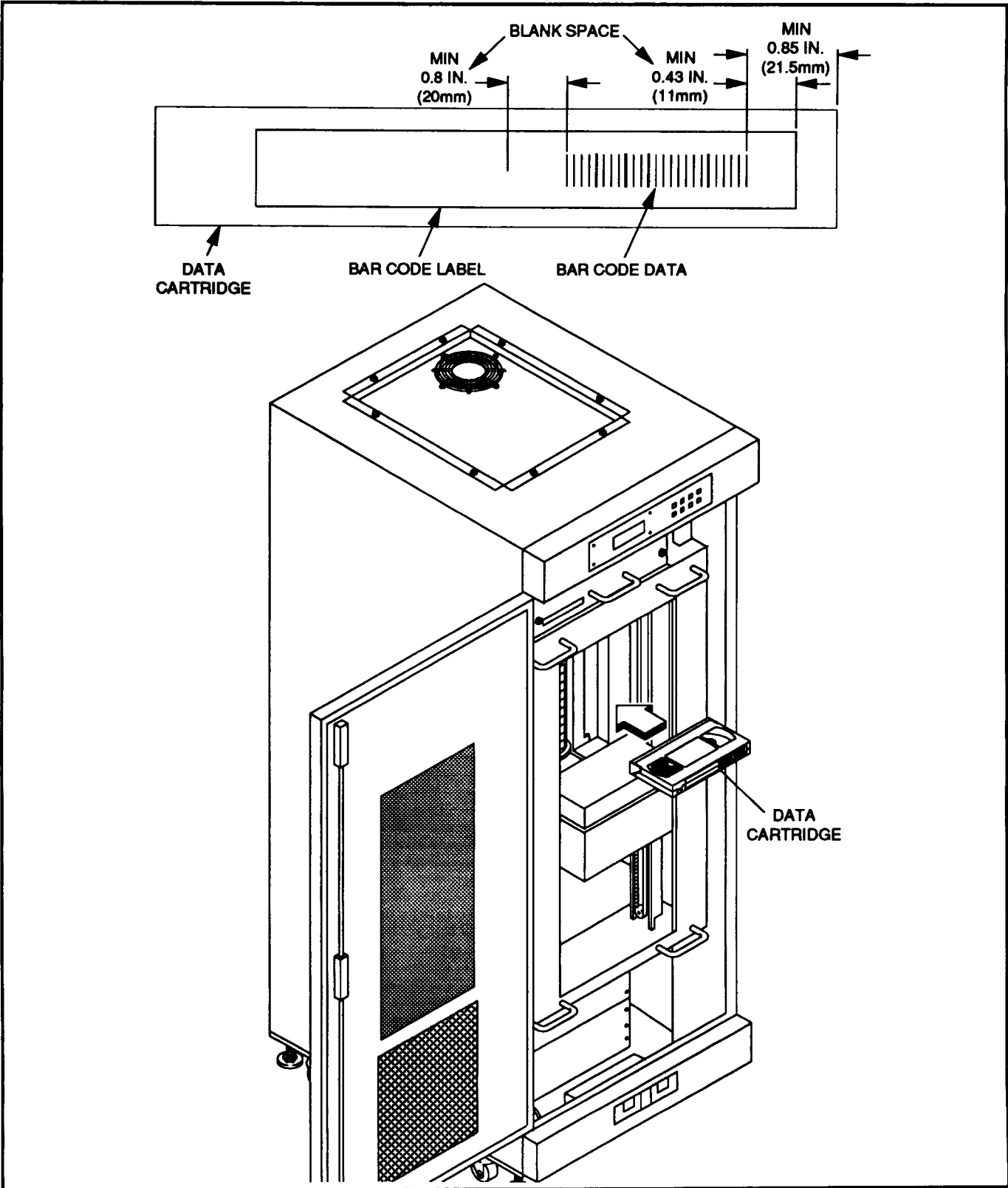

Figure 3-3. Bar Code Label and Data Cartridge Loading

A maximum of 13 characters may be used. The following information is provided to assist in the manufacture of bar code labels (refer to Figure 3-3):

- A 20.0 mm (0.8 in.) blank space (minimum) must exist between the left side of the bar code label and the bar code data.
- A 11.0 mm (0.43 in.) blank space (minimum) must exist between the right side of the bar code label and the bar code data.

Both standard and custom bar code labels are available from your Distributor. Refer to Section 1 for more information on obtaining bar code labels.

Labels must be placed on each data cartridge inserted in the RSS-48b as follows.

1. Clean area where bar code label is being placed using a damp cloth . Remove old bar code labels if present.
2. Place bar code label in the cartridge recess area as shown in Figure 3-3. When placing label:
  - Make sure the labels fit squarely on the cartridges in the bar code label area.
  - When the label is properly affixed, a 21.5 mm (0.85 in.) blank space (minimum) will exist between the right side of the data cartridge and the bar code data.
  - Avoid touching the bar code whenever possible.

### 3.4.2. LOADING DATA CARTRIDGES

**NOTE** Data cartridges should only be loaded with the RSS-48b in local operating mode (all button lights off).

Data cartridge loading consists of inserting up to 48 data cartridges into the RSS-48b rotary storage drum as described below and illustrated in Figure 3-3.

The data cartridges recommended for use by the RSS-48b are Metrum Data Cartridges. These data cartridges are specially designed for use in all Metrum Tape Drives.

**NOTE** Use of other than approved medium may result in degraded performance and/or may void the warranty of the tape drive. Refer to the Operator's Manual or User's Guide supplied with the tape drive for more information.

1. Verify that bar code labels have been installed in accordance with the instructions provided in paragraph 3.4.1.
2. Close the front door.
3. Use the LEFT and RIGHT buttons to move the rotary storage drum to the desired face.

4. Open the front door.

**WARNING**

Do not operate the RSS-48b with the front door open. Both electrical shock hazard and mechanical hazard from moving parts exist when operating the RSS-48b with the door open.

**WARNUNG**

Die RSS-48b nicht bei geöffneter Fronttür betreiben. Sowohl die Gefahr eines elektrischen Schlags als auch die Gefahr durch sich bewegende Teile besteht, wenn die RSS-48b bei offener Tür betrieben wird.

**AVERTISSEMENT**

Ne pas utiliser le RSS-48b quand le panneau avant est ouvert. Il existe des dangers d'électrocution et des risques de blessures provenant de pièces mécaniques en mouvement lorsqu'on utilise le RSS-48b avec le panneau avant ouvert.

5. Make sure the bin is clean and clear of obstructions.
6. Load data cartridges in the desired bins of the current face.
  - Verify that data cartridges are loaded with the tape cover entering the bin first. The write protect tab should be at the back left corner and the bar code label on the right side.
  - Once installed, the data cartridge must be completely in the bin.
7. Close the front door when finished.
8. Repeat steps 3 through 7 until all data cartridges are installed.

### 3.4.3. UNLOADING DATA CARTRIDGES

**NOTE** Data cartridges should only be unloaded with the RSS-48b in local operating mode (all button lights off).

1. Use the LEFT and RIGHT buttons to move the rotary storage drum to the desired face.
2. Open the front door.

**WARNING**

Do not operate the RSS-48b with the front door open. Both electrical shock hazard and mechanical hazard from moving parts exist when operating the RSS-48b with the door open.

**WARNUNG**

Die RSS-48b nicht bei geöffneter Fronttür betreiben. Sowohl die Gefahr eines elektrischen Schlags als auch die Gefahr durch sich bewegende Teile besteht, wenn die RSS-48b bei offener Tür betrieben wird.

**AVERTISSEMENT**

Ne pas utiliser le RSS-48b quand le panneau avant est ouvert. Il existe des dangers d'électrocution et des risques de blessures provenant de pièces mécaniques en mouvement lorsqu'on utilise le RSS-48b avec le panneau avant ouvert.

3. Unload data cartridges from the desired bins of the current face.
4. Close the front door when finished.
5. Repeat steps 1 through 4 until the desired data cartridges have been removed.

### 3.4.4. DATA CARTRIDGES HANDLING

Data cartridges are manufactured to strict standards and licensing agreements. They must be handled carefully and protected from mechanical shock and contamination. See Figure 3-4 for an illustration of cartridge features.

Store cartridges in protective sleeve whenever they are removed from the RSS-48b rotary storage drum. Data cartridges being stored for a long period of time should be placed in the optional protective case. Cases should always be stored on edge (not more than two high) in a cool, dry area (ideally 20° C at 50% RH). Avoid storing cartridges in direct sunlight or near heat sources. Store cartridges with the tape fully rewound. If the tape appears to be rewound unevenly, rewind again to obtain an even tape pack.

Cartridges must be kept at room temperature for at least one hour prior to use. Use of a cold cartridge in a warm drive can result in moisture condensation within the tape drive. Moisture in the tape drive can cause drive and/or tape damage.

Recorded data cartridges must be protected from magnetic fields. Placing a recorded data cartridge within a magnetic field may modify or erase the data.

The data cartridge has a write protect tab located at the back left edge of the cartridge. The write protect tab can be removed to prevent recording on the cartridge tape. Place adhesive tape over write protect slot to re-record on the data cartridge.

Each cartridge has a hinged protective cover over its tape access edge. This cover opens automatically when the cartridge is loaded into the tape drive, and closes when the data cartridge is removed from the tape drive. The cover protects the tape from damage and contamination in the rotary storage drum. The cover should not be opened when the cartridge is out of the RSS-48b. Do not touch the tape surface. Contaminants from your skin may deteriorate the tape coating and cause data dropouts.

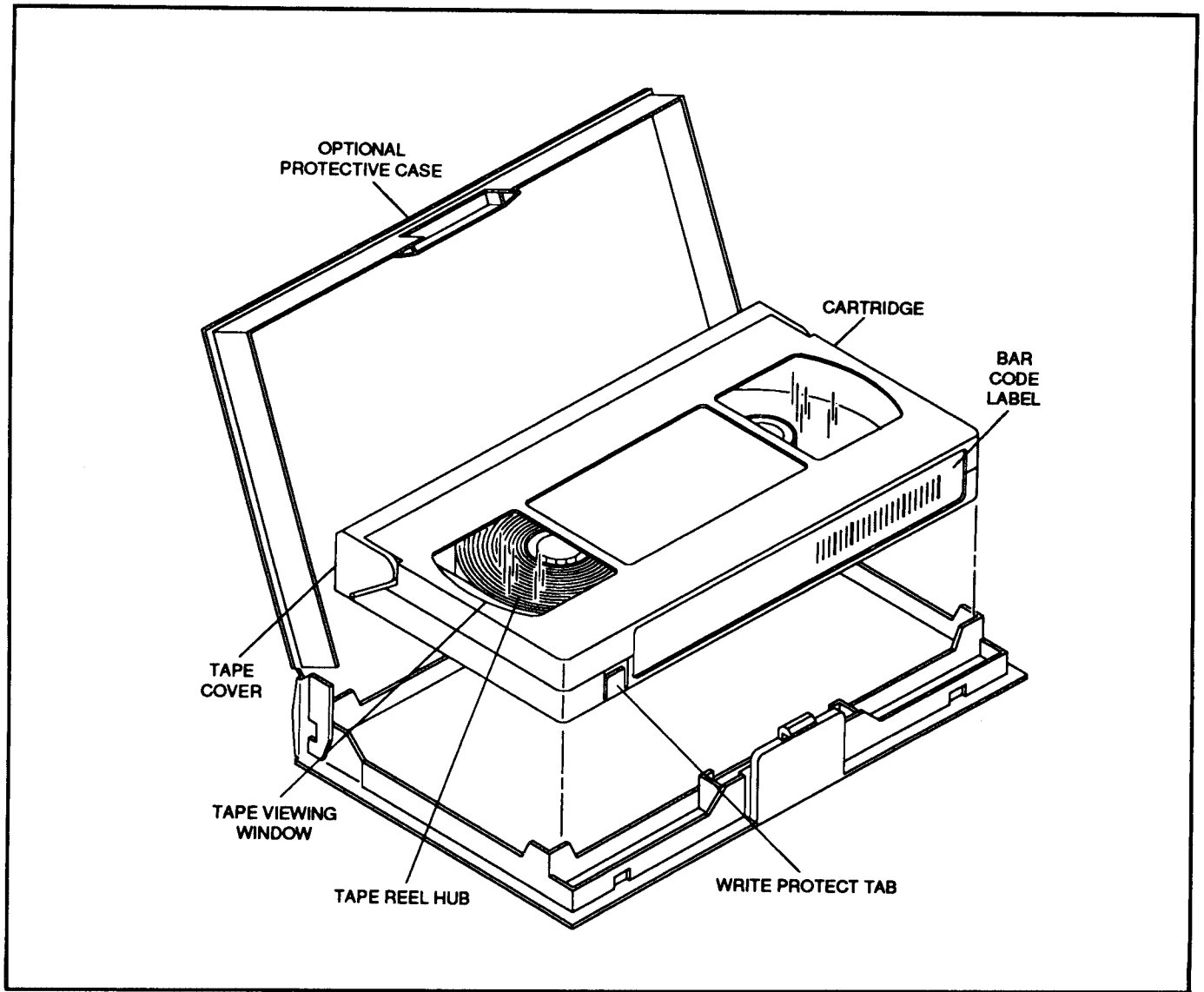

Figure 3-4. RSS-48b Data Cartridge

## 3.5. LOCAL OPERATING PROCEDURES

The following instructions are provided to power-up and operate the RSS-48b using the front panel.

### 3.5.1. POWER-UP

Procedures to power-up the RSS-48b are as follows (see Figure 3-5):

1. Prior to powering up the RSS-48b, verify that the RSS-48b:
  - has been properly installed and configured using the instructions provided in Section 2.
  - is loaded with the desired amount of data cartridges in the desired bin positions. Also make sure each data cartridge is affixed with a bar code label.
2. Set both front panel circuit breakers to OFF.
3. Open the front door, and perform a visual inspection of the inside of the RSS-48b to ensure that there are no foreign objects present. Verify that all installed data cartridges are not protruding from the face of the rotary storage drum.
4. Physically move the the Elevator Assembly (up/down) and the Handler Assembly (in/out) to verify a full range of free movement.
5. Set the power switches on the tape drive(s) to ON.
6. Close the front door.
7. Plug the RSS-48b power cable into the proper source.
8. Set the front panel drive circuit breaker to ON. Verify each tape drive performs a successful power-up.
9. Set the front panel system circuit breaker to ON. Verify that:
  - the rotary storage drum rotates CW to the next face position.
  - the handler moves to the full out or middle position (whichever is closest).
  - the elevator moves to the closest bin number or position.
  - If any of the indications are incorrect, or if an error is displayed, troubleshoot using the information in Section 5 before proceeding.

### 3.5.2. OPERATION

Local operation of the RSS-48b consists of moving data cartridges to/from the installed tape drives and the rotary storage bin, and reading bar code data. Refer to paragraph 3.2.1 earlier in this section for information on the operational panel controls and indicators.

### 3.5.3. POWER DOWN

Procedures to power down the RSS-48b are as follows (see Figure 3-5):

1. Verify that data cartridges are not currently loaded in the tape drives. If necessary, open the door and manually eject the data cartridge.
2. Verify that the rotary storage drum, handler, and elevator motors are NOT turning, then set the front panel system circuit breaker to OFF.
3. Set the front panel drive circuit breaker to OFF.

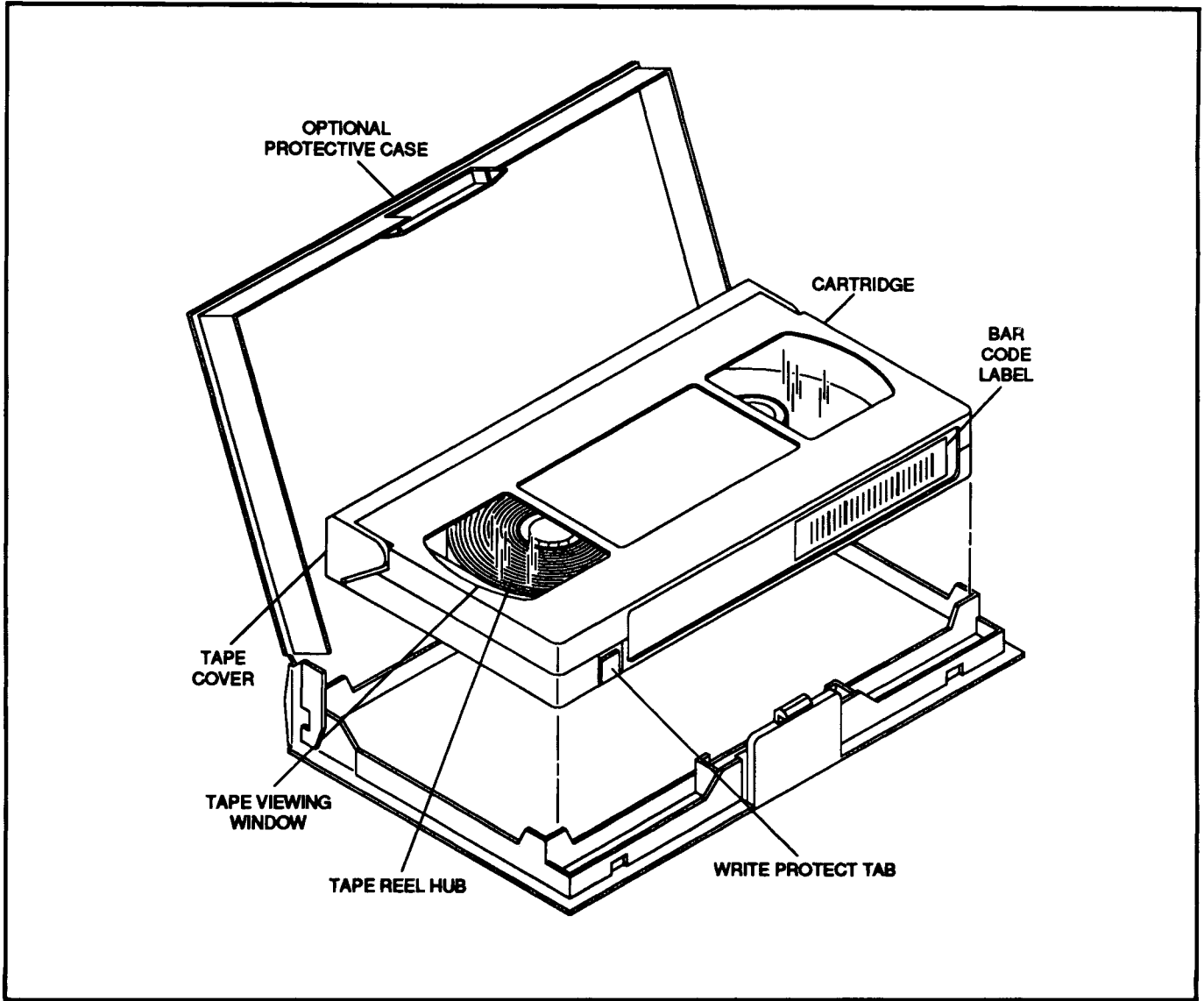

Figure 3-4. RSS-48b Data Cartridge

## 3.5. LOCAL OPERATING PROCEDURES

The following instructions are provided to power-up and operate the RSS-48b using the front panel.

### 3.5.1. POWER-UP

Procedures to power-up the RSS-48b are as follows (see Figure 3-5):

1. Prior to powering up the RSS-48b, verify that the RSS-48b:
  - has been properly installed and configured using the instructions provided in Section 2.
  - is loaded with the desired amount of data cartridges in the desired bin positions. Also make sure each data cartridge is affixed with a bar code label.
2. Set both front panel circuit breakers to OFF.
3. Open the front door, and perform a visual inspection of the inside of the RSS-48b to ensure that there are no foreign objects present. Verify that all installed data cartridges are not protruding from the face of the rotary storage drum.
4. Physically move the the Elevator Assembly (up/down) and the Handler Assembly (in/out) to verify a full range of free movement.
5. Close the front door.
6. Plug the RSS-48b power cable into the proper source.
7. Set the front panel drive circuit breaker to ON. Verify each tape drive performs a successful power-up.
8. Set the front panel system circuit breaker to ON. Verify that:
  - the rotary storage drum rotates CW to the next face position.
  - the handler moves to the full out or middle position (whichever is closest).
  - the elevator moves to the closest bin number or position.
  - If any of the indications are incorrect, or if an error is displayed, troubleshoot using the information in Section 5 before proceeding.

### 3.5.2. OPERATION

Local operation of the RSS-48b consists of moving data cartridges to/from the installed tape drives and the rotary storage bin, and reading bar code data. Refer to paragraph 3.2.1 earlier in this section for information on the operational panel controls and indicators.

### 3.5.3. POWER DOWN

Procedures to power down the RSS-48b are as follows (see Figure 3-5):

1. Verify that data cartridges are not currently loaded in the tape drives. If necessary, open the door and manually eject the data cartridge.
2. Verify that the rotary storage drum, handler, and elevator motors are NOT turning, then set the front panel system circuit breaker to OFF.
3. Set the front panel drive circuit breaker to OFF.

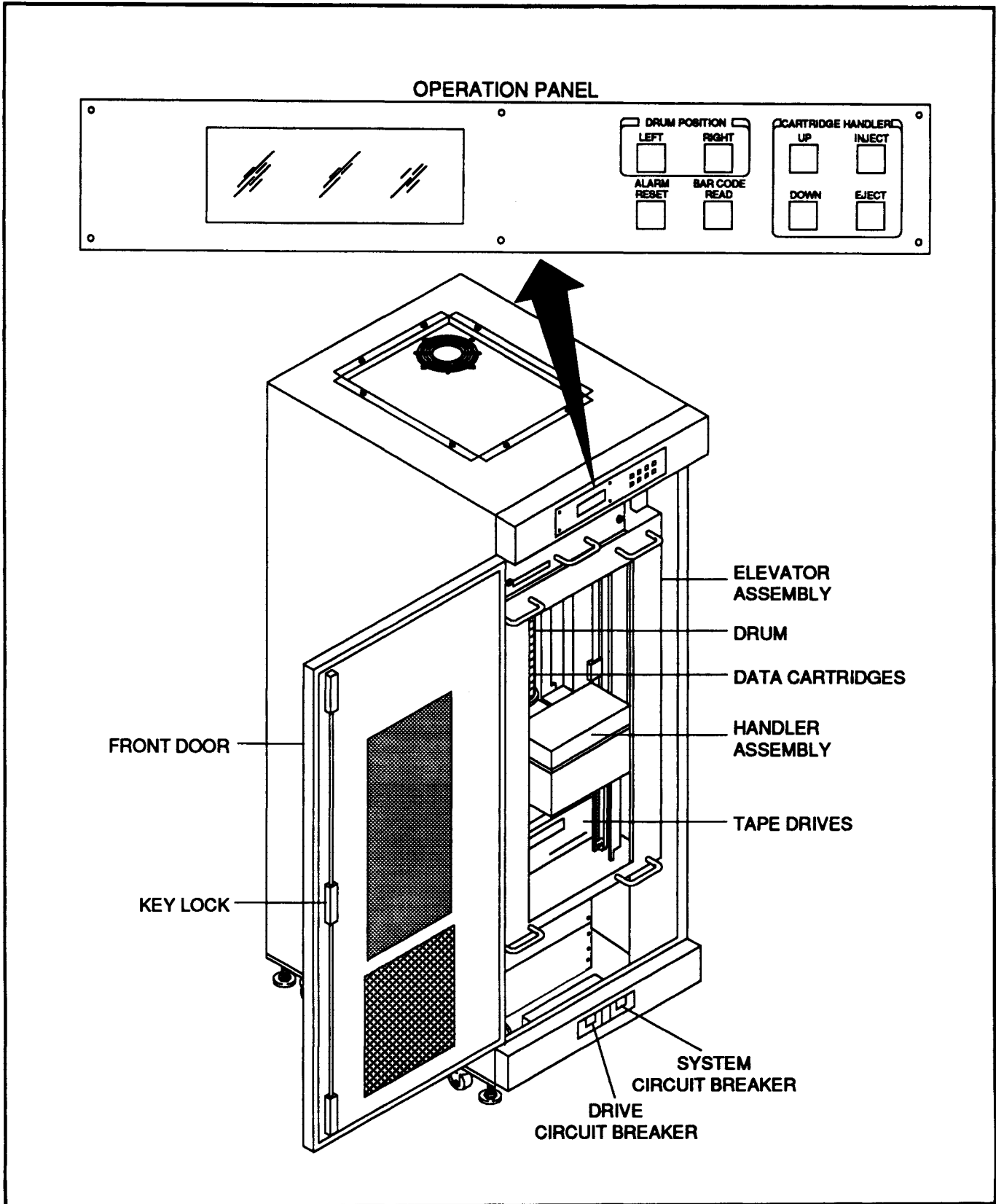

Figure 3-5. Local Operation

## 3.6. REMOTE OPERATING PROCEDURES

The following instructions are provided to power-up and operate the RSS-48b using a controller over the RS-232C serial interface.

### 3.6.1. POWER-UP

1. Prior to powering up the RSS-48b, verify that the RSS-48b:
  - has been properly installed and configured using the instructions provided in Section 2. Record the communication parameters set-up in paragraph 2.7.4.3 (e.g. baud rate, parity, data bits, etc) for use in configuring the communication program's parameters.
  - is loaded with the desired amount of data cartridges in the desired bin positions. Also make sure each data cartridge is affixed with a bar code label.
2. Apply power to the controller and verify proper boot-up.
3. Power-up the RSS-48b using the instructions provided in paragraph 3.5.1.
4. Load the communication program in the controller and set the parameters to match the RSS-48b communication parameters (refer to paragraph 2.7.4.3).
5. The RSS-48b is now ready to receive control commands and data from the controller via the RS-232C serial interface.

### 3.6.2. OPERATION

Remote operation of the RSS-48b consists of issuing commands to the RSS-48b from a controller over the full duplex asynchronous serial RS-232C (EIA-232-C) interface. Paragraph 3.7 contains information to assist in operation of the RSS-48b using remote commands. Included are descriptions of all of the commands that the RSS-48b supports.

**NOTE** Commands that initiate mechanical actions (e.g. rotary storage drum movement, elevator movement, etc) will not be executed or completed if the front door is opened. See paragraph 3.7.21 for more information about open door interrupts.

### 3.6.3. POWER DOWN

Power down the RSS-48b using the instructions provided in paragraph 3.5.3.

## 3.7. COMMANDS

**NOTE** For best results, commands should be executed one at a time, and then each response analyzed to verify proper execution before executing the next command.

Commands from the controller to the RSS-48b, and responses from the RSS-48b to the controller are variable length ASCII characters bracketed by an alphabetic header character "O", and a terminator character ">". The command format is shown on the next page.

**NOTE** Commands are displayed, and should be sent, using **CAPITAL LETTERS only**.

Header	Command I.D.	Parameters	Term
"O"	A to J, L to Z, and KS	Upper case alphanumeric characters, (special char allowed)	">"

**NOTE** Terminator is selected using the CPU CCA S001 position 4. Refer to Section 2 for more information.

This paragraph contains descriptions of all of the commands that the RSS-48b supports. The commands are listed in alphabetical order, and each command contains the following information.

- **Purpose:** a brief statement of the command's purpose.
- **Command Format:** describes the command syntax and parameter limits.
- **Example:** provides an example of the command.
- **Response:** describes normal response (including returned data) and possible error conditions that may occur when executing the command.

### 3.7.1. ALARM CLEAR COMMAND

#### PURPOSE

This command is used to terminate active alarm(s) (both audio and output(s) at CN007 on the motherboard).

**NOTE** Refer to Section 2 for more information on alarm outputs.

#### COMMAND FORMAT

O F \* \* \* \_ >

Position	Acceptable Entries	Description
1	O	Header character
2	F	Command I.D. character
3	*	Fill character
4	*	Fill character
5	*	Fill character
6	0 to 3	Alarm(s) to Clear. Alarm 1 is the system alarm, alarms 2 and 3 are defined by the user. Select 0 to reset all three alarms. Refer to Section 2 for more information.
7	>	Terminator character

#### EXAMPLE

Send the following command to reset all three alarms: *OF\*\*\*0>*

#### RESPONSE

This command does not return a response.

## 3.7.2. ALARM ON COMMAND

### PURPOSE

This command is used to sound the audio alarm and send output(s) to CN007 on the motherboard.

**NOTE** Refer to Section 2 for more information on alarm outputs.

### COMMAND FORMAT

O Y \* \* \* \_ >

Position	Acceptable Entries	Description
1	O	Header character
2	Y	Command I.D. character
3	*	Fill character
4	*	Fill character
5	*	Fill character
6	0 to 3	Alarm(s) to Activate. Alarm 1 is the system alarm, alarms 2 and 3 are defined by the user. Select 0 to activate all three alarms. Refer to Section 2 for more information.
7	>	Terminator character

### EXAMPLE

Send the following command to activate all three alarms: *OY\*\*\*0>*

### RESPONSE

This command does not return a response.

### 3.7.3. BAR CODE READ COMMAND 1

#### PURPOSE

This command is used to read all 12 data cartridge bar codes loaded in the rotary storage drum face specified.

**NOTE** To interrupt and stop the Bar Code Read Command 1, send "OKS\*\*\*>".

#### COMMAND FORMAT

O H \_ \_ \_ \* >

Position	Acceptable Entries	Description
1	O	Header character
2	H	Command I.D. character
3	A,B,C,D, or 1	Drum Face. A, B, C, D or 1 (1 = current face).
4-5	01 or 12	Direction. 01 is top to bottom. 12 is bottom to top.
6	*	Fill character
7	>	Terminator character

#### EXAMPLE

Send the following command to read all data cartridge bar codes in face A from top to bottom: *OHA01\*>*

#### RESPONSE

Returns the following response depending on how the command was executed.

- Returns the following string twelve times (representing each bin in the face) if the command executed normally:

O H \_ \_ \_ . . . \_ >

Position	Returned Character	Description
1	O	Header character
2	H	Command I.D. character
3	A,B,C, or D	Drum Face Read. A, B, C, or D.
4-5	01 to 12	Drum Bin Level Read. Drum Bin number is from 01 to 12.
6-18	Any	Returns 13 characters of bar code data read. If bar code data could not be read, "*****" is returned.
19	>	Terminator character

**NOTE** To interrupt and stop the Bar Code Read Command 1, send "OKS\*\*\*>".

- error code* - if the read did not finish or finished abnormally, the alarm is sounded and an error code is returned. Table 3-3 contains a list of possible error codes.

### 3.7.4. BAR CODE READ COMMAND 2

#### PURPOSE

This command is used to read the data cartridge bar code in the tape drive or rotary storage drum bin specified.

#### COMMAND FORMAT

O M \_ \_ \_ \* >

Position	Acceptable Entries	Description
1	O	Header character
2	M	Command I.D. character
3	A,B,C,D, 1, or 3	Drum Face or Tape Drive. Drum Face is A, B, C, D or 1 (1 = current face). Tape Drive = 3.
4-5	01 or 12	Drum Bin or Tape Drive number. If Drum Bin is being read, number must be from 01 to 12. If Tape Drive being read, number must be 01 or 02.
6	*	Fill character
7	>	Terminator character

#### EXAMPLE

Send the following command to read the data cartridge bar code in the bottom tape drive: *OM302\*>*

#### RESPONSE

Returns the following response depending on how the command was executed.

- Returns the following string if the command executed normally:

O M \_ \_ \_ . . . \_ >

Position	Returned Character	Description
1	O	Header character
2	M	Command I.D. character
3	A,B,C,D, or 3	Drum Face/Tape Drive Read. Drum Face is A, B, C, or D. Tape Drive is 3.
4-5	01 to 12	Drum Bin Level/Tape Drive Read. If a Drum Bin is being read, returns 01 to 12. If a Tape Drive is being read, returns 01 or 02.
6-18	Any	Returns 13 characters of bar code data read. If bar code data could not be read, "*****" is returned.
19	>	Terminator character

- error code* - if the read did not finish or finished abnormally, the alarm is sounded and an error code is returned. Table 3-3 contains a list of possible error codes.

### 3.7.5. CARTRIDGE CARRYING COMMAND 1

#### PURPOSE

This command is used to grab a data cartridge from the designated rotary storage drum bin and store it into another designated drum bin. Checking whether the data cartridge bar code matches the bar code specified in the command before executing the action is selectable.

#### COMMAND FORMAT

The command format is as follows:

O Q \_ \_ \_ \_ Q \_ \_ \_ \_ . . . \_ >

Position	Acceptable Entries	Description
1	O	Header character
2	Q	Command I.D. character
3	A,B,C, or D	Original Drum Face must be A, B, C, or D.
4-5	01 or 12	Original Drum Bin number must be from 01 to 12.
6	Y or N	Check Bar Code Data is Yes or No.
7	Q	Separator character
8	A,B,C, or D	Destination Drum Face must be A, B, C, or D.
9-10	01 or 12	Destination Drum Bin number must be from 01 to 12.
11-23	Any	Desired bar code fixed at 13 characters. If bar code data is less than 13 characters, a space (20h) must be used as fill. Must match upper and lower case. If Check Bar Code Data is N, this field can be left blank.
24	>	Terminator character

#### EXAMPLE

Send the following command to extract a data cartridge from bin A 03 and store it in bin B 03 only if the bar code at bin A 03 reads "123ABCDEF4567": *OQA03YQB03123ABCDEF4567>*

#### RESPONSE

Returns the following response depending on how the command was executed.

- *OD>* - if the command executed normally.
- *OE>* - if the bar code could not be read, the alarm is sounded and the command is aborted.
- *OBbar code>* - if the bar codes did not match, the alarm is sounded and the data cartridge bar code is returned. The command is also aborted.
- *error code* - if the bar codes matched, but the store did not finish or finished abnormally, the alarm is sounded and an error code is returned. Table 3-3 contains a list of possible error codes.

### 3.7.6. CARTRIDGE CARRYING COMMAND 2

#### PURPOSE

This command is used to grab a data cartridge that has been ejected from the designated tape drive and load it into the next designated tape drive, without a checking the bar code.

For this command to execute, the data cartridge must have been previously ejected from the tape drive.

#### COMMAND FORMAT

O P \_ \_ \* \* >

Position	Acceptable Entries	Description
1	O	Header character
2	P	Command I.D. character
3	1 or 2	Original Tape Drive Number must be 1 or 2.
4	1 or 2	Destination Tape Drive Number must be 1 or 2.
5	*	Fill character
6	*	Fill character
7	>	Terminator character

#### EXAMPLE

Send the following command to extract a data cartridge from the top tape drive and store it in the bottom tape drive: *OP12\*\*>*

#### RESPONSE

Returns the following response depending on how the command was executed.

- *OV>* - if the command executed normally.
- *error code* - if the store did not finish or finished abnormally, the alarm is sounded and an error code is returned. Table 3-3 contains a list of possible error codes.

### 3.7.7. CARTRIDGE HANDLER MOVE COMMAND

#### PURPOSE

This command is used to position the Handler Assembly to the tape drive or rotary storage drum bin specified.

**NOTE** Drum rotation is also performed if necessary.

#### COMMAND FORMAT

O R \_ \_ \* \* >

Position	Acceptable Entries	Description
1	O	Header character
2	R	Command I.D. character
3	A,B,C,D, 1, or 2	Destination Drum Face/Tape Drive number. Drum Face must be A, B, C, or D. Tape Drive Number must be 1 or 2.
4-5	01 or 12	Destination Drum Bin number must be from 01 to 12. If a Tape Drive being read, number is disregarded.
6	*	Fill character
7	>	Terminator character

#### EXAMPLE

Send the following command to position the Handler Assembly at the bottom tape drive: *OR200\*>*

#### RESPONSE

Returns the following response depending on how the command was executed.

- *OK>* - if the command executed normally.
- *error code* - if the command did not finish or finished abnormally, the alarm is sounded and an error code is returned. Table 3-3 contains a list of possible error codes.

### 3.7.8. CARTRIDGE LOAD COMMAND 1

#### PURPOSE

This command is used to grab a data cartridge from the designated rotary storage drum bin, and load it into the designated tape drive without checking the bar code.

**NOTE** This command is similar to the Cartridge Load Command 2, where the bar code is checked prior to execution.

#### COMMAND FORMAT

O D \_ \_ \_ \_ >

Position	Acceptable Entries	Description
1	O	Header character
2	D	Command I.D. character
3	A,B,C, or D	Originating Drum Face number must be A, B, C, or D.
4-5	01 or 12	Originating Drum Bin number must be from 01 to 12.
6	1 to 2	Destination Tape Drive Number must be 1 or 2.
7	>	Terminator character

#### EXAMPLE

Send the following command to extract a data cartridge from bin A 03 and load it into the top tape drive: *ODA031>*

#### RESPONSE

Returns the following response depending on how the command was executed.

- *OD>* - if the command executed normally.
- *error code* - if the load did not finish or finished abnormally, the alarm is sounded and an error code is returned. Table 3-3 contains a list of possible error codes.

### 3.7.9. CARTRIDGE LOAD COMMAND 2

#### PURPOSE

This command is used to grab a data cartridge from the designated rotary storage drum bin, and load it into the designated tape drive *ONLY WHEN* the data cartridge bar code matches the bar code specified in the command.

**NOTE** This command is similar to the Cartridge Load Command 1, where the bar code is not checked.

#### COMMAND FORMAT

O B \_ \_ \_ \_ B \_ . . . \_ >

Position	Acceptable Entries	Description
1	O	Header character
2	B	Command I.D. character
3	A,B,C, or D	Originating Drum Face number must be A, B, C, or D.
4-5	01 or 12	Originating Drum Bin number must be from 01 to 12.
6	1 to 2	Destination Tape Drive Number must be 1 or 2.
7	B	Separator character
8-20	Any	Desired bar code fixed at 13 characters. If bar code data is less than 13 characters, a space (20h) must be used as fill. Must match upper and lower case. If Check Bar Code Data is N, this field can be left blank.
21	>	Terminator character

#### EXAMPLE

Send the following command to extract a data cartridge from bin A 03 and load it into the top tape drive only if the bar code at A 03 reads "123ABCDEF4567":  
**OBA031B123ABCDEF4567>**

#### RESPONSE

Returns the following response depending on how the command was executed.

- **OK>** - if the command executed normally.
- **OE>** - if the bar code could not be read, the alarm is sounded and the command is aborted.
- **OBbar code>** - if the bar codes did not match, the alarm is sounded and the data cartridge bar code is returned. The command is also aborted.
- **error code** - if the bar codes matched, but the load did not finish or finished abnormally, the alarm is sounded and an error code is returned. Table 3-3 contains a list of possible error codes.

## 3.7.10. CARTRIDGE STORE COMMAND 1

### PURPOSE

This command is used to grab a data cartridge that has been ejected from the designated tape drive and store it into the designated rotary storage drum bin, without checking the bar code.

For this command to execute, the data cartridge must have been previously ejected from the tape drive.

**NOTE** This command is similar to the Cartridge Store Command 2, where the bar code is checked prior to execution.

### COMMAND FORMAT

O V \_ \_ \_ \_ >

Position	Acceptable Entries	Description
1	O	Header character
2	V	Command I.D. character
3	A,B,C, or D	Destination Drum Face number must be A, B, C, or D.
4-5	01 or 12	Destination Drum Bin number must be from 01 to 12.
6	1 to 2	Originating Tape Drive Number must be 1 or 2.
7	>	Terminator character

### EXAMPLE

Send the following command to extract a data cartridge from the top tape drive and store in bin A 03: *OVA031>*

### RESPONSE

Returns the following response depending on how the command was executed.

- *OV>* - if the command executed normally.
- *error code* - if the store did not finish or finished abnormally, the alarm is sounded and an error code is returned. Table 3-3 contains a list of possible error codes.

### 3.7.11. CARTRIDGE STORE COMMAND 2

#### PURPOSE

This command is used to grab a data cartridge from the designated tape drive and store it into the designated rotary storage drum bin, **ONLY WHEN** the data cartridge bar code matches the bar code specified in the command.

**NOTE** This command is similar to the Cartridge Store Command 1, where the bar code is not checked.

#### COMMAND FORMAT

O A \_ \_ \_ \_ B . . . \_ >

Position	Acceptable Entries	Description
1	O	Header character
2	A	Command I.D. character
3	A,B,C, or D	Destination Drum Face number must be A, B, C, or D.
4-5	01 or 12	Destination Drum Bin number must be from 01 to 12.
6	1 to 2	Originating Tape Drive Number must be 1 or 2.
7	B	Separator character
8-20	Any	Desired bar code fixed at 13 characters. If bar code data is less than 13 characters, a space (20h) must be used as fill. Must match upper and lower case. If Check Bar Code Data is N, this field can be left blank.
21	>	Terminator character

#### EXAMPLE

Send the following command to extract a data cartridge from the top tape drive and store in bin A 03 only if the bar code at the top tape drive reads "123ABCDEF4567":  
**OAA031B123ABCDEF4567>**

#### RESPONSE

Returns the following response depending on how the command was executed.

- **OK>** - if the command executed normally.
- **OE>** - if the bar code could not be read, the alarm is sounded and the command is aborted.
- **OBbar code>** - if the bar codes did not match, the alarm is sounded and the data cartridge bar code is returned. The command is also aborted.
- **error code** - if the bar codes matched, but the store did not finish or finished abnormally, the alarm is sounded and an error code is returned. Table 3-3 contains a list of possible error codes.

## 3.7.12. DISPLAY COMMAND

### PURPOSE

This command is used to write a string of 13 alphanumeric characters to the front panel display tape drive line.

**NOTE** The only special characters that can be used are a space and hyphen(-).

### COMMAND FORMAT

O X \* \* \* \_ B \_ . . . \_ >

Position	Acceptable Entries	Description
1	O	Header character
2	X	Command I.D. character
3	*	Fill character
4	*	Fill character
5	*	Fill character
6	1 to 2	Tape Drive display line must be 1 or 2.
7	B	Separator character
8-20	Any	Desired data string fixed at 13 characters. If string data is less than 13 characters, a space (20h) must be used as fill.
21	>	Terminator character

### EXAMPLE

Send the following command to display "UNLOAD TAPE" to the front panel display on the bottom tape drive's line: *OX\*\*\*2BUNLOAD TAPE >*

### RESPONSE

This command does not return a response.

### 3.7.13. DOOR SENSOR/CARRIER CARTRIDGE SENSE COMMAND

#### PURPOSE

This command is used to determine the status of the front door (open or closed), current rotary storage drum face (A-D), and if a data cartridge is currently loaded in the Handler Assembly.

#### COMMAND FORMAT

O S \* \* \* \* >

Position	Acceptable Entries	Description
1	O	Header character
2	S	Command I.D. character
3	*	Fill character
4	*	Fill character
5	*	Fill character
6	*	Fill character
7	>	Terminator character

#### EXAMPLE

Send the following command to request the current status of the door, rotary storage drum face, and Handler Assembly: OS\*\*\*\*>

#### RESPONSE

Returns the following response depending on how the command was executed.

- Returns the following string if the command executed normally.

O S \_ \* \_ \_ >

Position	Returned Character	Description
1	O	Header character
2	S	Command I.D. character
3	0 or 1	Front Door status returns 1 if open, 0 if closed.
4	*	Fill character
5	0 or 1	Handler Assembly status returns 0 if a Data Cartridge is not loaded or 1 if it is loaded.
6	A,B,C, or D	Drum Face status returns current drum face.
7	>	Terminator character

- error code* - if the read status did not finish or finished abnormally, the alarm is sounded and an error code is returned. Table 3-3 contains a list of possible error codes.

### 3.7.14. DRUM SET COMMAND

#### PURPOSE

This command is used to position the rotary storage drum face as specified.

#### COMMAND FORMAT

O J \_ \* \* \* >

Position	Acceptable Entries	Description
1	O	Header character
2	J	Command I.D. character
3	A,B,C,D	Drum Face of A, B, C, or D.
4	*	Fill character
5	*	Fill character
6	*	Fill character
7	>	Terminator character

#### EXAMPLE

Send the following command to position the rotary storage drum to face A: *OJA\*\*\*>*

#### RESPONSE

Returns the following response depending on how the command was executed.

- *OF>* - if the command executed normally.
- *error code* - if the command did not finish or finished abnormally, the alarm is sounded and an error code is returned. Table 3-3 contains a list of possible error codes.

### 3.7.15. EJECT COMMAND

#### PURPOSE

This command is used to grab a data cartridge from the tape drive or rotary storage drum bin positioned directly in front of the Handler Assembly.

If grabbing a data cartridge from a tape drive, it must have been previously ejected.

#### COMMAND FORMAT

O E \* \* \* \* >

Position	Acceptable Entries	Description
1	O	Header character
2	E	Command I.D. character
3	*	Fill character
4	*	Fill character
5	*	Fill character
6	*	Fill character
7	>	Terminator character

#### EXAMPLE

Send the following command to grab the data cartridge directly in front of the Handler Assembly: *OE\*\*\*\*>*

#### RESPONSE

Returns the following response depending on how the command was executed.

- *OD>* - if the command executed normally.
- *error code* - if the command did not finish or finished abnormally, the alarm is sounded and an error code is returned. Table 3-3 contains a list of possible error codes.

## 3.7.16. INJECT COMMAND

### PURPOSE

This command is used to insert the data cartridge currently loaded in the Handler Assembly into the tape drive or rotary storage drum bin positioned directly in front of the Handler Assembly.

If inserting a data cartridge into a tape drive, it must not have a data cartridge currently loaded.

### COMMAND FORMAT

O T \* \* \* \* >

Position	Acceptable Entries	Description
1	O	Header character
2	T	Command I.D. character
3	*	Fill character
4	*	Fill character
5	*	Fill character
6	*	Fill character
7	>	Terminator character

### EXAMPLE

Send the following command to insert the data cartridge currently loaded in the Handler Assembly in the rotary storage drum bin or tape drive directly in front of the Handler Assembly: *OT\*\*\*\*>*

### RESPONSE

Returns the following response depending on how the command was executed.

- *OV>* - if the command executed normally.
- *error code* - if the command did not finish or finished abnormally, the alarm is sounded and an error code is returned. Table 3-3 contains a list of possible error codes.

### 3.7.17. MANUAL OPERATION ENABLE COMMAND

#### PURPOSE

This command is used to enable or disable the front panel operations panel. When disabled, all pushbuttons are green.

#### COMMAND FORMAT

O I \_ \* \* \* >

Position	Acceptable Entries	Description
1	O	Header character
2	I	Command I.D. character
3	N or F	Operational Panel Pushbutton status returns N if enabled or F if disable.
4	*	Fill character
5	*	Fill character
6	*	Fill character
7	>	Terminator character

#### EXAMPLE

Send the following command to disable the operational front panel: *OIF\*\*\*>*

#### RESPONSE

Returns the following response depending on how the command was executed.

- *error code* - if the command did not finish or finished abnormally, the alarm is sounded and an error code is returned. Table 3-3 contains a list of possible error codes.

### 3.7.18. RESET COMMAND

#### PURPOSE

This command is used to cause the RSS-48b microprocessor to reset to power-up conditions (same as the manual CPU reset).

#### COMMAND FORMAT

O N \* \* \* \* >

Position	Acceptable Entries	Description
1	O	Header character
2	N	Command I.D. character
3	*	Fill character
4	*	Fill character
5	*	Fill character
6	*	Fill character
7	>	Terminator character

#### EXAMPLE

Send the following command to reset the RSS-48b: *ON\*\*\*\*>*

#### RESPONSE

This command does not return a response.

### 3.7.19. COMMAND SUMMARY

A summary of all commands used during remote operation of the RSS-48b are listed in Table 3-1.

Table 3-1. Command Summary

I.D.	Description	Page
A	Cartridge Store Command 2 (w/ bar code read)	3-26
B	Cartridge Load Command 2 (w/ bar code read)	3-24
C	Not Used.	N/A
D	Cartridge Load Command 1 (w/o bar code read)	3-23
E	Eject Command	3-30
F	Alarm Clear Command	3-16
H	Bar Code Read Command 1 (read entire drum face)	3-18
I	Manual Operation Enable/Disable Command	3-32
J	Drum Face Set Command	3-29
K	Expanded Commands	3-18
KS	Bar Code Read Stop Command (refer to H)	3-18
M	Bar Code Read Command 2 (read 1 cartridge)	3-19
N	Initialize Command	3-33
O	(Command Header only)	ALL
P	Cartridge Carrying Command (drive to drive)	3-21
Q	Cartridge Carrying Command (bin to bin)	3-20
R	Cartridge Handler Moving Command	3-22
S	Door Sensor / Carrier Cartridge Sensor Command	3-28
T	Inject Command	3-31
V	Cartridge Store Command 1 (w/o bar code read)	3-25
X	Display Command	3-27
Y	Alarm On Command	3-17
>	(Command Terminator only)	ALL

### 3.7.20. RESPONSE SUMMARY

A summary of all responses returned during remote operation of the RSS-48b are listed in Table 3-2.

Table 3-2. Response Summary

Response	I.D.	Description
OB"data">	A, B, Q	Cartridge bar code does not correspond
OD>	D, E, Q	Normal operation response
OE>	A, B, Q	Cartridge bar code not read
OF>	J	Normal operation response
OG2>	A, B, D, H, J, M, Q, V	Drum unable to move
OG3>	A, B, D, H, M, P, Q, R, V	Elevator unable to move
OG5>	A, B, D, E, P, Q, T, V	Carrier unable to move
OH"data">	H, M	Cartridge bin #. & bar code data
OK>	A, B, R	Normal operation response
OL0>	All	Front door closed response
OL2>	All	Front door opened response
OF>	J	Normal operation response
ON1>	A, B, D, E, P, Q, V	Cartridge was not grabbed
ON2>	A, B, D, P, Q, T, V	Cartridge was not inserted
ON6>	Any	Command data error
OS0*0->	S	Front door closed. No Cartridge Drum face A - D
OS0*1->	S	Front door closed. Yes Cartridge Drum face A - D
OS1*0->	S	Front door open. No Cartridge Drum face A - D
OS1*1->	S	Front door open. Yes Cartridge Drum face A - D
OV>	P, T, V	Normal operation response

### 3.7.21. FRONT DOOR INTERRUPT

#### WARNING

Do not operate the RSS-48b with the front door open. Both electrical shock hazard and mechanical hazard from moving parts exist when operating the RSS-48b with the door open.

#### WARNUNG

Die RSS-48b nicht bei geöffneter Fronttür betreiben. Sowohl die Gefahr elektrischen Schocks als auch die Gefahr durch sich bewegende Teile besteht, wenn die RSS-48b bei offener Tür betrieben wird.

#### AVERTISSEMENT

Ne pas utiliser le RSS-48b quand le panneau avant est ouvert. Il existe des dangers d'électrocution et des risques de blessures provenant de pièces mécaniques en mouvement lorsqu'on utilise le RSS-48b avec le panneau avant ouvert.

Whenever the RSS-48b front door is opened or closed, a status message is sent to the controller. RSS-48b response, and the type of message returned to the controller is dependent on the current RSS-48b status.

- If the front door is opened while the RSS-48b is waiting for a command, "OL2" is sent to the controller. Any attempt to initiate a mechanical action (remote or front panel) is prohibited until the door is closed.
- If the front door is opened while the RSS-48b is performing any mechanical action (inject, eject, drum rotation, etc), all mechanical movement is halted, and a "OGx>" or "ONx>" response is sent to the controller. Any attempt to initiate a mechanical action (remote or front panel) is prohibited until the door is closed.

Once the RSS-48b front door is closed, the RSS-48b performs a power-up initialization (refer to paragraph 3.5.1), then sends an "OLO" status message to the controller. After the OLO is received, the RSS-48b is ready for normal operation.

#### NOTE

If the door was opened when the Handler was performing a mechanical action involving the cartridge (e.g. inject, eject, etc) the alarm will pulse on and off. If this occurs, open the door and verify that the cartridge is completely in the Handler or drum.

### 3.7.22. ERROR CODES

Table 3-3 lists the error messages associated with operating the RSS-48b using the RS-232C serial interface.

When an error is encountered, perform a visual inspection of the malfunctioning area. If the problem cannot be located, proceed as follows:

1. Record error message(s).
2. Power down then power-up the RSS-48b and controller using the instructions provided in this section.
3. Repeat process that caused error to be generated. If the identical error message(s) are re-displayed, troubleshoot the problem using the information in Section 5.

Table 3-3. Error Codes

Error	Description
OG2>	Rotary drum is not turning (generates an operational interrupt). May also be returned if the front door was opened during execution of a move command.
OG3>	Elevator is not moving (generates an operational interrupt). May also be returned if the front door was opened during execution of a move command.
OG5>	Handler is not moving (generates an operational interrupt). May also be returned if the front door was opened during execution of a move command.
OL0>	The front door has been closed and the RSS-48b has completed it's power-up sequence (refer to paragraph 3.5).
OL2>	The front door has been opened while the RSS-48b was not executing a mechanical command (generates an operational interrupt).
ON1>	Data cartridge cannot be removed from a drum-bin or tape drive (does not generate an operational interrupt). May also be returned if the front door was opened during execution of an eject command.
ON2>	Data cartridge cannot be inserted into the drum-bin or tape drive (does not generate an operational interrupt). May also be returned if the front door was opened during execution of an inject command.
ON6>	RSS-48b has received an incorrect command (does not generate an operational interrupt). May also be returned if the front door was opened during execution of a command.

## 3.8. MAINTENANCE

This paragraph provides operator preventive maintenance instructions for the RSS-48b.

### CAUTION

This equipment contains ESDS devices. Proper ESDS device handling procedures must be followed. Refer to the ESDS DEVICE HANDLING information at the front of this manual.

### 3.8.1. OPERATOR'S PREVENTIVE MAINTENANCE

**NOTE** Additional service oriented preventive maintenance (such as replacing motor's and cables) is provided in Section 5.

Operator's preventive maintenance for the RSS-48b consists of regular scheduled cleaning, and inspection of key items for excessive wear. Both general internal and external cleaning of the unit and cleaning of the tape drives with the manufacturer's recommended procedure are required. The recommended time intervals provided are to be considered maximum. Heavy usage, adverse conditions, or local maintenance procedures may dictate more frequent inspections. Table 3-4 contains a full list of periodic inspections and cleaning requirements.

### WARNING

Always remove power from the RSS-48b before performing any preventive maintenance. Shut down procedures are provided in paragraph 3.5.3.

### WARNUNG

Vor der Durchführung vorbeugender Wartungsarbeiten grundsätzlich die Stromzufuhr zum RSS-48b abschalten. Abschaltverfahren sind in Absatz 3.5.3 dargelegt.

### AVERTISSEMENT

Il faut toujours mettre le RSS-48b hors tension avant de procéder à l'arrêt se trouvent au sous-allinéa 3.5.3.

#### 3.8.1.1. Materials Required

The following materials are required to perform the maintenance procedures that follow.

- lint-free soft cotton cloth
- cotton swabs
- contact cleaning liquid
- isopropyl alcohol
- lens paper
- compressed air (can)
- 1 kg - (35.2 oz) compression/tension scale

In addition to the common materials, speciality Cleaning Kits may be required for preventive maintenance on the installed tape drive(s). Refer to the Operator's Manual or User's Guide provided with the tape drives for more information.

Table 3-4. Preventive Maintenance Procedures

ITEM	INTERVAL	INSPECT FOR	ACTION
Exterior	Monthly	Dust or any foreign matter	Clean as required. Use a lint-free cloth dampened with a mild commercial cleaning agent to wipe down all exterior surfaces.
Fans	Monthly	Dust or any foreign matter	Clean as required. Use a vacuum to keep clean and unobstructed.
Interior	Monthly	Dust or any foreign matter	Clean as required. See Figure 3-6. Open from door and remove panels as required to access interior and clean using a vacuum. Pay attention to the card cage and elevator areas where plastic particles and dust accumulate.
Handler Assy	Daily	Dust or any foreign matter	Clean as required. See Figure 3-6. Clean fingers and slides using a lint-free cloth dampened with isopropyl alcohol. Clean camera/LED using lens paper.
Tape Drive(s) Insertion Door	Weekly	Dust or any foreign matter	Clean as required. Use a lint-free cloth dampened with isopropyl alcohol.
Rotary Drum	Monthly	Dust or any foreign matter	Clean as required. See Figure 3-6. Clean bin slots using a lint-free cloth dampened with alcohol.
Air Filter	Monthly	Dust or any foreign matter	Clean as required. See Figure 3-6. Remove 8 screws and remove filter. Clean using a vacuum and compressed air (< 20 lbs (9 kg)). Replace element when dirty.
Drive Belts	Monthly	Tension and condition	Inspect as required. See Figure 3-6. Inspect elevator, drum, and handler drive belts for excessive wear. Also check elevator belt for proper tension.
Tape Drive(s)	-----	External and internal (tape deposits or any foreign matter)	Clean as required. Instructions are provided in the Tape Drive Operator's Manual or User's Guide.

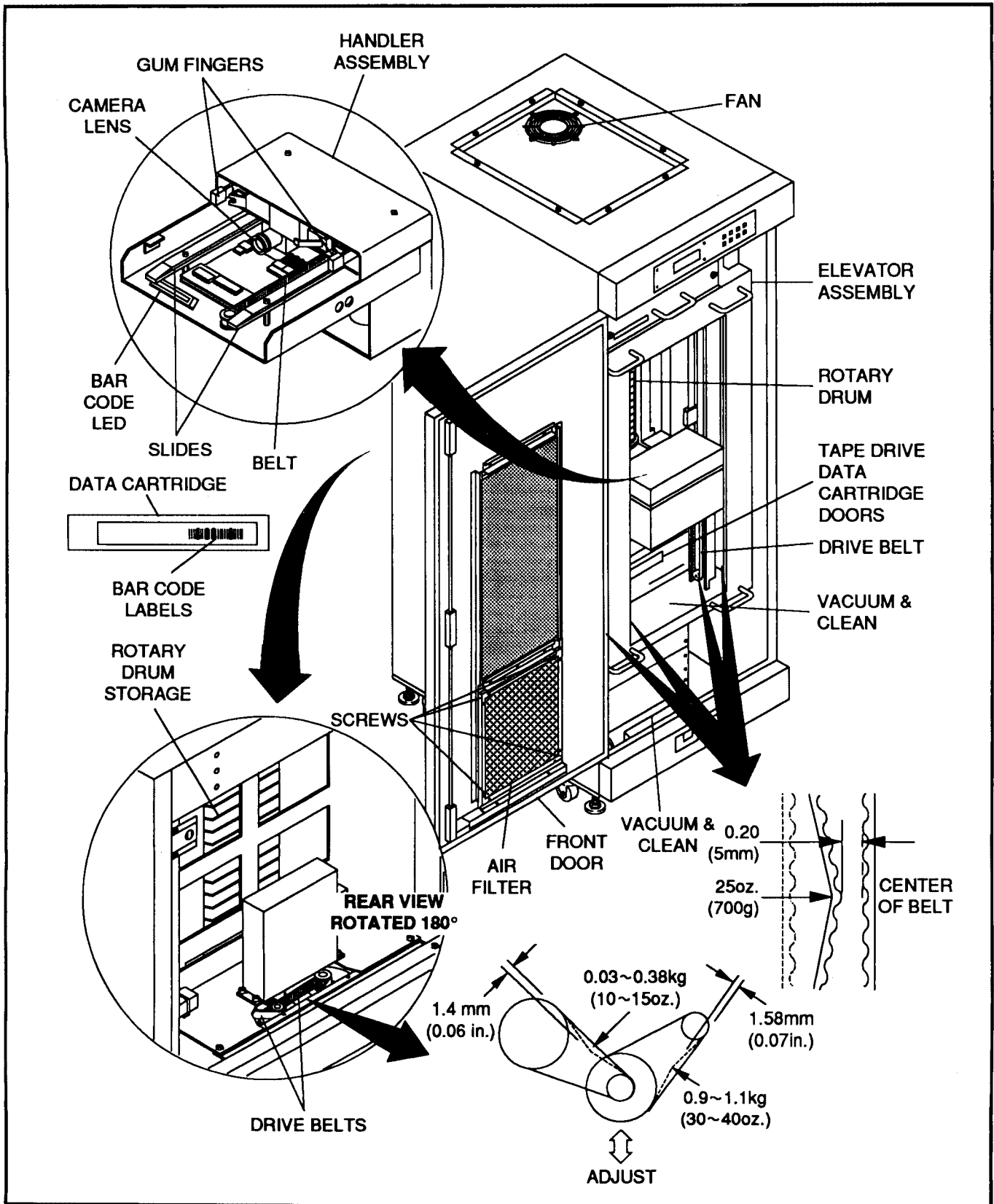

Figure 3-6. RSS-48b Operator's Preventive Maintenance

# 4. PRINCIPLES OF OPERATION

---

## 4.1. GENERAL

This section describes the functional operation of the RSS-48b. Descriptions are supported by simplified block diagrams and a system interconnection diagram. The system block and interconnection diagrams are located in Section 8. The circuit descriptions provide an analysis of the circuitry within the RSS-48b.

**NOTE** This manual contains the information required to repair the RSS-48b only to the lowest field replaceable unit, as determined by the manufacturer. This repair philosophy is basically a module exchange, with some individual high-wear parts included.

## 4.2. FUNCTIONAL DESCRIPTION

The RSS-48b is an automatic, random access, mass data storage system that combines high performance robotics and Metrum's helical-scan technology Tape Drives (provided separately) to provide over 500 gigabytes (0.5 terabytes) of data storage. Actual storage capacity is dependent on the number and model of tape drives installed and the type data cartridge used.

Data is stored on up to 48 one-half inch data cartridges, each identified with a different bar code. Using Y/Z robotics and a rotating storage drum, the RSS-48b is capable of retrieving a specific data cartridge in less than 8 seconds. Once retrieved, the data cartridge can be moved to a tape drive, or loaded into a different bin in the storage drum.

Functionally, the RSS-48b is comprised of 6 blocks (see Figure 4-1).

- **Control Block** – provides the overall control of the rotary storage drum position, movement and positioning of the elevator and handler motors, and reading the bar code data. Both local operation (using the front panel keys and display) and remote operation (via the RS-232C serial interface) are provided. It also provides the signals that drive the display and illuminates the push button LED's. Physically, the control block consists of seven removable CCA's and a motherboard.
- **Local Control Block** – provides the operator interface to the RSS-48b. Visual indications are in the form of a 256 x 64 character florescent display and pushbutton LED's. Manual control is in the form of eight pushbutton switches.
- **Drum Block** – stores up to 48 data cartridges. The rotary storage drum is physically rotated by a motor/driver combination using signals from the Control Block. Two sensors located on the top of the drum provide the Control Block with location information for precision placement.
- **Elevator Block** – provides the Y-axis movement (up/down) that moves the data cartridges between the rotary storage drum and tape drive(s). The elevator is physically moved by a motor/driver combination using signals from the Control Block. A sensor located on the elevator chassis provides the Control Block with current bin number or tape drive location information for precision placement.

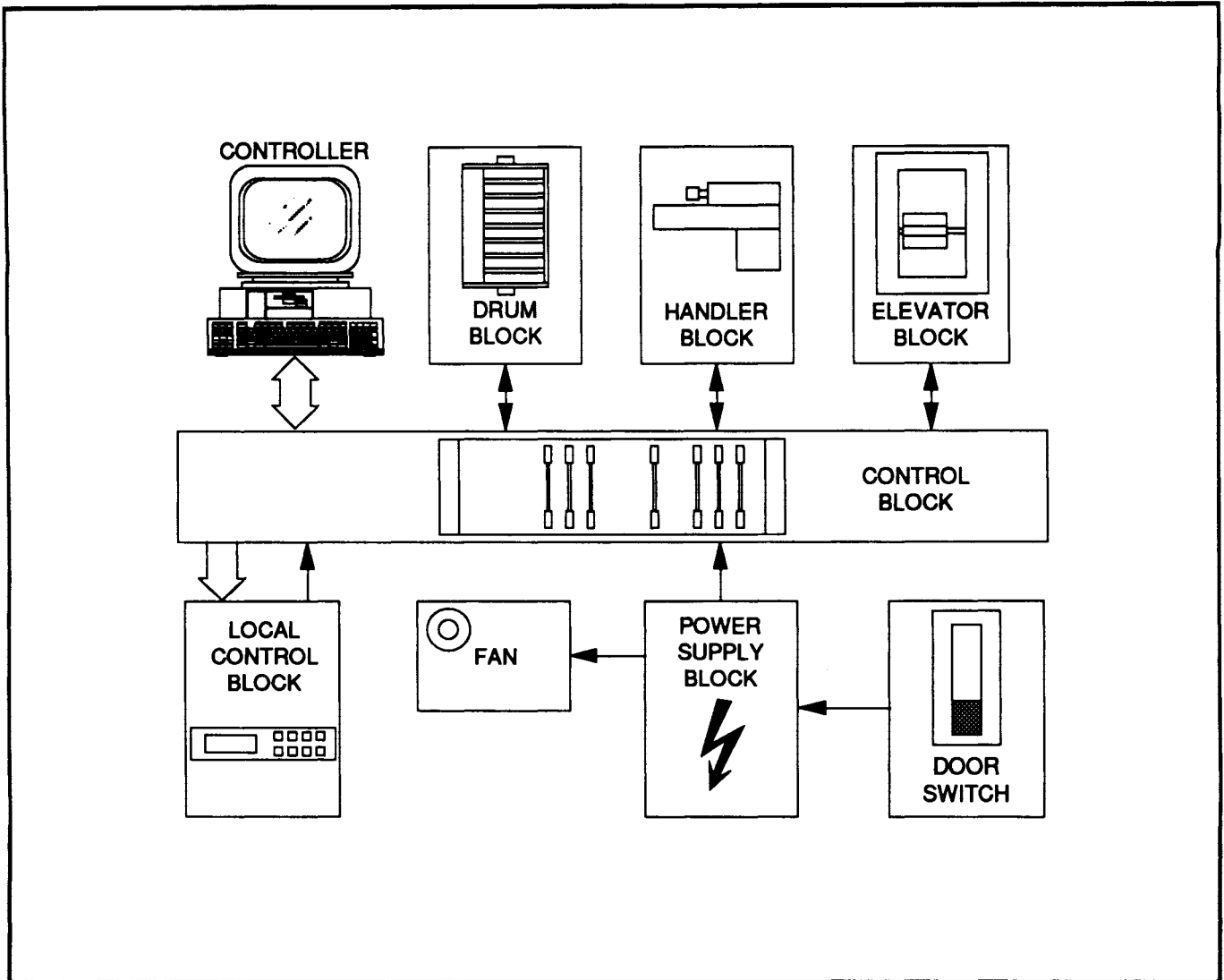

Figure 4-1. RSS-48b Simplified Functional Diagram

- Handler Block** – grabs, holds, and provides Z-axis movement (in/out) of the data cartridges to/from the rotary storage drum or tape drive(s). The cartridge is physically grabbed and moved using drive signals from the Control Block. Three sensors located on the handler chassis provides the Control Block with current location information for precision placement. A sensor switch is used to indicate if a cartridge is loaded. Also in the Handler Block is a bar code reader that reads the bar code labels located on the data cartridges. This data is decoded and sent to the Control Block.
- Power Supply Block** – provides the voltage conversion and protection circuitry for RSS-48b operation.

## 4.3. CIRCUIT DESCRIPTION

**NOTE** This manual contains the information required to repair the RSS-48b only to the lowest field replaceable unit, as determined by the manufacturer. This repair philosophy is basically a module exchange, with some individual high-wear parts included.

### 4.3.1. CONTROL BLOCK

Figure 8-1 depicts the assemblies discussed in the following paragraphs.

The Control Block contains the CCA's that provide overall control of internal RSS-48b operations. These CCA's contain the microprocessor, sensor detection, serial interface, motor control, and display control circuitry necessary for local and remote operation.

This block is comprised of the following replaceable assemblies and modules:

- CPU CCA
- Sensor # 1 CCA
- Sensor # 2 CCA
- Drive and I/O CCA
- FIP I/O CCA
- Pulse Motor Control #1 CCA
- Pulse Motor Control #2 CCA
- Motherboard CCA (not field replaceable)

#### 4.3.1.1. CPU CCA (Slot #1)

The CPU CCA contains the microprocessor, Read Only Memory (ROM), and Random Access Memory (RAM) circuitry used to provide overall control of the RSS-48b's mechanical parts.

- 8-bit 6502 series microprocessor controls internal RSS-48b operations and communications. The microprocessor can be reset externally (pushbutton switch), or is automatically reset if the +5V power supply voltage drops below +4.5 Vdc.
- 16 kbyte of non-volatile ROM contains the microprocessor programming instructions.
- 8 kbyte of volatile RAM is used by the microprocessor during operation.

All communications with the various RSS-48b assemblies are accomplished using a 16-bit address bus (via the Sensor #1 CCA) and an 8-bit data bus. The data and address buses are buffered (separately) prior to output/input to or from any CCA. All CCA's except PM Controller #1 and #2 have the peripheral interface ICs. PM Controller #1 and #2 CCA's each have an 8-bit 6502 series microprocessor.

External communications are accomplished using the RS-232C serial interface.

The CPU CCA has three LED's and two switches that perform the following functions.

**NOTE** See Section 5 for location and additional descriptions of the LED's and switches.

- R/W LED (D001) – indicates the transfer direction (R/W) of the microprocessor.
- SYNC LED (D002) – indicates a microprocessor fetch operation.
- NMI LED (D003): indicates a non-maskable external interrupt.
- Four Position Dip Switch (S001) – sets communication parameters.
- RESET Switch (S002) – resets the microprocessor to it's power-up state. Also resets the other microprocessors on the remaining CCA's in the Control Block.

#### 4.3.1.2. Sensor 1 CCA (Slot #2)

The Sensor #1 CCA decodes instructions from the CPU CCA and controls the input/output of the remaining CCA's in the Control Block via the address bus. This CCA also generates a signal (CPU NG) to control the mechanical assemblies in the event of CPU CCA microprocessor runaway.

The Sensor #1 CCA also processes data received from the Elevator and Drum Block gray code and slit sensors, and routes it to the CPU CCA.

- Elevator Assembly gray code sensor indicates the current rotary storage drum bin number (01 to 12) or tape drive (01 or 02) position.
- Elevator Assembly slit sensor indicates when the elevator is precisely positioned.
- Drum Assembly gray code sensor indicates the current rotary storage drum face (A to D) position.
- Drum Assembly slit sensor indicates when the rotary storage drum is precisely positioned.

The Sensor #1 CCA has 10 LED's and three switches that perform the following functions.

**NOTE** See Section 5 for location and additional descriptions of the LED's and switches.

- ELEVATOR SLIT LED (D002) – indicates the elevator is positioned correctly.
- ELEVATOR GRAY 2 to 6 LED's (D007 to D003) – indicates the current rotary storage drum-bin number.
- DRUM SLIT LED (D009): indicates that the rotary storage drum is positioned correctly.
- DRUM GRAY 1 & 2 LED's (D011 and D012) – indicates the current rotary storage drum-face number.
- CPU NG LED (D013) indicates CPU CCA microprocessor runaway.
- IDEN SELECT Switch (S001) – not user selectable.
- PIO ADDRESS SELECT Switch (S002) – not user selectable.
- MODE SELECT Switch (S003) – sets communication parameters.

### 4.3.1.3. Sensor 2 CCA (Slot #3)

Operating under control of the CPU CCA, the Sensor #2 CCA controls overall operation of the handler assembly. Functions include:

- **Bar Code Reader** – activates the bar code LED and also receives the decoded bar code data.
- **Z-Axis Motor** – drives the Z-Motor (correct direction and duration).
- **Carriage Sensors** – receives and processes data to determine if the handler's carriage is at the full forward, middle, or full rear position.
- **Cartridge Switch** – receives and processes data to determine if a data cartridge is currently loaded.

This CCA also detects front panel button presses and front door status (open or closed).

If microprocessor runaway occurs at the CPU CCA, the Sensor #2 CCA disables Z-Axis motor operation.

The Sensor #2 CCA has 15 LED's and two switches that perform the following functions.

**NOTE** See Section 5 for location and additional descriptions of the LED's and switches.

- **BAR READ LED (D1)** – indicates that a Bar Code Read Command (1 or 2) is being executed.
- **Z-DIRECTION LED (D6)** – indicates the carrier is moving away from rotary storage drum/tape drive.
- **Z-ON/OFF LED (D7)** – indicates the Z-Axis motor is operating.
- **Z-MOTOR N.G. LED (D17)** – indicates the Z-Axis motor is drawing excessive current.
- **CASSETTE SWITCH LED (D18)** – indicates that a cartridge is in the handler.
- **Z-FRONT LED (D22)** – indicates that the handler is in the full forward position.
- **Z-MIDDLE LED (D23)** – indicates that the handler is in the middle position.
- **Z-BACK LED (D24)** – indicates that the handler is in the full rear position.
- **BAR DETECT LED (D25)** – indicates if a cartridge is in front of, or in the handler.
- **FRONT DOOR OPEN LED (D28)** – indicates that the front door is open.
- **ALARM RESET SWITCH LED (D29)** – indicates that the front panel ALARM pushbutton is being pressed.
- **KEY 0-2 LED's (D30 to D32)** – indicates that one of the front panel pushbuttons is being pressed.
- **Switch (S1)** – not user selectable.
- **Switch (S2)** – not user selectable.

#### 4.3.1.4. Drive and I/O CCA (Slot #4)

Operating under control of the CPU CCA, the Drive and I/O CCA provides the drive for the:

- handler solenoid to grab/release the data cartridges (+12 Vdc).
- eight front panel pushbutton LED's (+5 Vdc).
- audio alarm located on the Motherboard CCA (+5 Vdc).
- three alarm outputs to drive external devices from CN007 on the Motherboard CCA (110 Vac @ 0.5 A or 24 Vdc @ 1 A).

The Drive and I/O CCA has 12 LED's and two switches that perform the following functions.

**NOTE** See Section 5 for location and additional descriptions of the LED's and switches.

- ALARM 1 LED (D1) – indicates that the system error alarm (0) is active.
- ALARM 2 and 3 LED's (D12 and D13) – indicates that the user defined error alarm (1 or 2) is active.
- PLUNGER OPEN LED (D2) – indicates that the handler's solenoid plunger is activated, causing the fingers to open.
- ALARM LED (D3) – indicates that the alarm pushbutton LED is on.
- BAR CODE READ LED (D4) – indicates that the bar code read pushbutton LED is on.
- ELEVATOR DOWN LED (D5) – indicates that the down pushbutton LED is on.
- CASSETTE EJECT (D6) – indicates that the eject pushbutton LED is on.
- ELEVATOR UP LED (D7) – indicates that the up pushbutton LED is on.
- CASSETTE INJECT (D8) – indicates that the inject pushbutton LED is on.
- DRUM-TURN RIGHT LED (D9) – indicates that the right pushbutton LED is on.
- DRUM-TURN LEFT LED (D10) – indicates that the left pushbutton LED is on.
- Switch (S1) – not user selectable.
- Switch (S2) – not user selectable.

#### 4.3.1.5. FIP (Fluorescent Indicator Panel) I/O CCA (Slot #7)

Operating under control of the CPU CCA, the FIP I/O CCA provides the data and timing signals for the florescent display assembly on the front panel.

The FIP I/O CCA has three LED's that perform the following functions.

**NOTE** See Section 5 for location and additional descriptions of the LED's.

- BLANK LED (D1) – indicates blanking during initialization.
- GATE LED (D2) – indicates initialization.
- FRAME LED (D3) – indicates normal display operation.

#### 4.3.1.6. Pulse Motor Controller CCA (Slots #8 and #9)

Operating under control of the CPU CCA, the Pulse Motor Controller CCA's drive the drum and elevator motors via Pulse Motor Driver Assemblies. Pulse Motor Controller #1 drives the drum motor, and Pulse Motor Controller #2 drives the elevator motor.

**NOTE** The only physical difference between Pulse Motor Controller #1 and #2 is the ROM (U11), S1 switch positions, and the marking on the top ejectors. Operation for both CCA's is identical.

Each CCA has its own 8-bit 6502 series microprocessor and 8 kbyte of non-volatile ROM to control motor operations. Digital motor position data from the CPU CCA is converted to five analog signals. These pulsed outputs determine motor direction, duration, and speed. The motor control outputs are adjustable to compensate for differences between drum and elevator motor operation. Pulse width is 40µsec for the drum motor and 94µsec for the elevator.

If microprocessor runaway occurs at the CPU CCA, the Pulse Motor Controller CCA's disable motor operation.

The Pulse Motor Controller CCA's have eight LED's and one switch that perform the following functions.

**NOTE** See Section 5 for location and additional descriptions of the LED's and switches.

- CPU NG LED (D2) *both CCA's* – indicates that CPU CCA runaway has occurred.
- SYNC LED (D3) *both CCA's* – indicates normal operation or CPU CCA runaway.
- DRUM SLIT (D5) *PM Cont#1* – indicates rotary storage drum rotation.
- ELEVATOR SLIT (D7) *PM Cont#2* – indicates elevator movement.
- ID Switch (S1) – sets CCA identification (to PM#1 or PM#2).

#### 4.3.1.7. Motherboard CCA

The Motherboard CCA provides power, signal, and data distribution to all CCA's that comprise the Control Block. This CCA also houses the alarm buzzer, RS-232C serial interface connector, and Alarm connector.

**NOTE** The Motherboard CCA is not field replaceable.

## 4.3.2. LOCAL CONTROL BLOCK

Figure 8-1 depicts the assemblies discussed in the following paragraphs.

The Local Control Block contains the assemblies and modules that provides the operator interface when using the RSS-48b in local mode.

- Operator to RSS-48b – commands are initiated by selecting eight pushbuttons.
- RSS-48b to Operator – the operator is informed of tape drive configurations, remote operation messages and prompts, and various other messages on a florescent display. The eight pushbuttons also have LED's that provide status.

This block is comprised of the following replaceable assemblies and modules:

- Display Assembly
- Operation Panel Switch CCA

### 4.3.2.1. Display CCA

The Display Assembly is a self-contained 256 x 64 character florescent display that, under control of the CPU CCA (via the FIP I/O CCA), provides the operator with various messages and prompts.

The logic circuitry operates from +5 Vdc provided by the Power Supply Block.

### 4.3.2.2. Operation Panel Switch CCA

The Operation Panel Switch CCA contains the eight switches that control RSS-48b operation (drum left, drum right, elevator up, elevator down, cartridge inject, cartridge eject, alarm reset, and bar code read) via the Sensor #2 CCA.

The CCA consists of a printed circuit card with eight momentary switches. Pressing a button pulls a corresponding line in the switch matrix low.

Each of the eight buttons is provided with an LED to notify the operator that the button function(s) have been disabled via the RS-232C serial interface. Drive for the LED's is provided by the Drive and I/O CCA.

### 4.3.3. DRUM BLOCK

Figures 4-2 and 8-1 depict the assemblies discussed in the following paragraphs.

The Drum Block contains the modules, motors, and physical hardware assemblies required to store and access up to 48 data cartridges.

Physically, the rotary storage drum is mounted on a bearing assembly allowing it to rotate easily CW or CCW. The bottom of the drum is actually a large spur gear. This gear is driven by the drum motor via two reduction gears. The reduction gears and high torque stepper motor provide the precise movement control required.

Control over motor speed, duration, and direction is provided by the CPU CCA via the Pulse Motor Controller #1 CCA and Pulse Motor Driver #1. Sensors located on top of the rotary storage drum provide current position information.

This block is comprised of the following replaceable assemblies and modules:

- Pulse Motor Driver #1 Module
- Drum Motor Assembly
- Drum Sensor CCA's

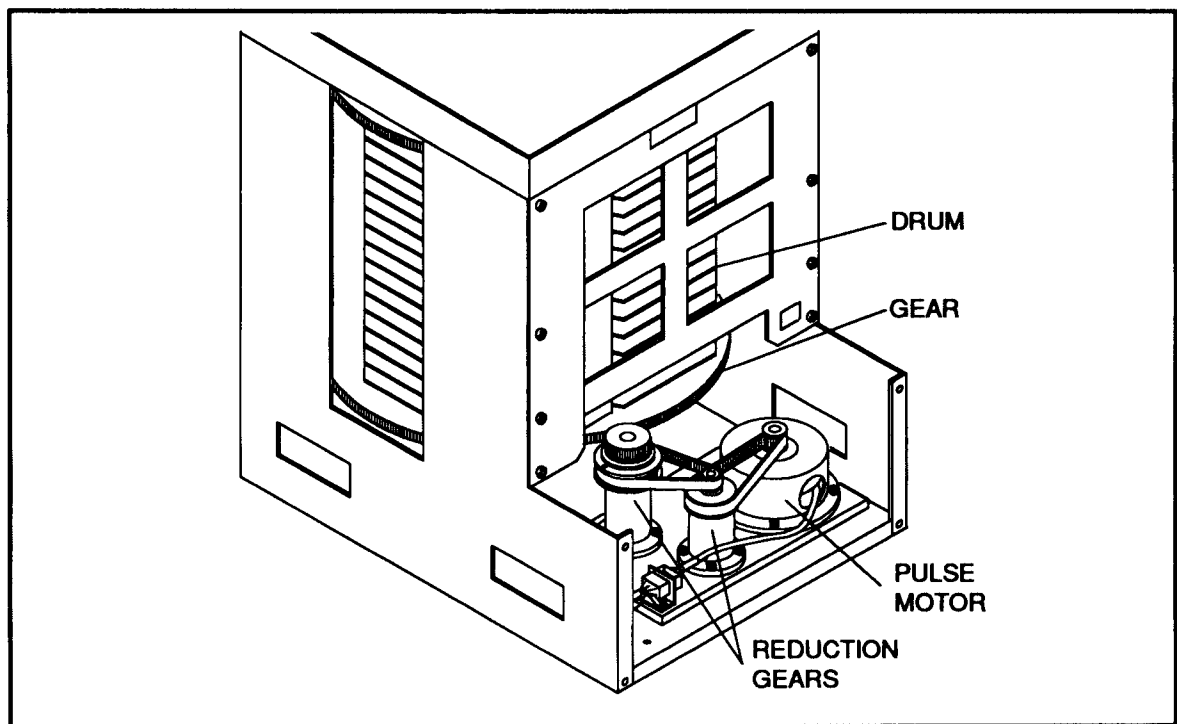

Figure 4-2. Drum Motor

### 4.3.3.1. Pulse Motor Driver #1 Module

The Pulse Motor Driver #1 module provides the high current to drive the five phases of the drum stepper motor. Maximum current is adjustable to 1.4 amps. Control over speed, direction, and duration is determined by the pulse input provided by the Pulse Motor Controller #1 CCA. Drive is provided by 100 Vac from the Power Supply Block only when the front door is closed.

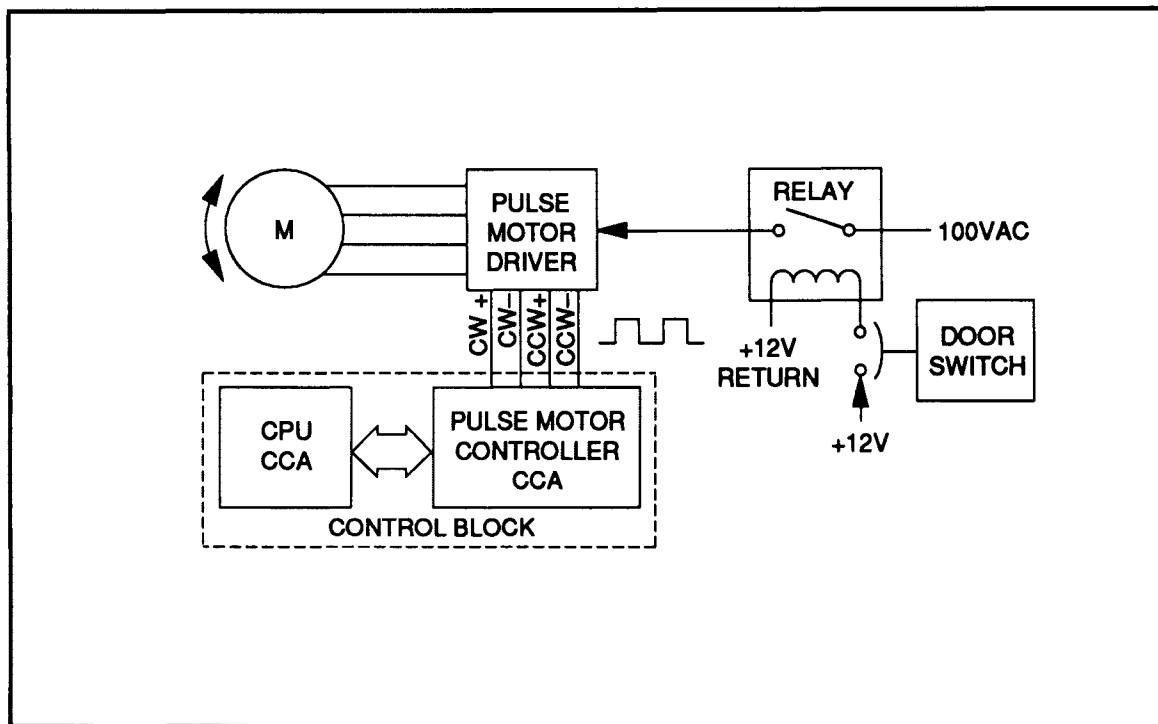

Figure 4-3. Pulse Motor Operation

### 4.3.3.2. Drum Pulse Motor

The Drum Pulse Motor is a hybrid five phase stepper motor that rotates the rotary storage drum in precisely controlled 0.36° steps.

The stepper motor provides 1,000 steps per revolution. The motor is driven by a five-phase drive current provided by the Pulse motor Driver #1 module under control of Pulse Motor Controller #1 CCA.

### 4.3.3.3. Drum Sensors

Two different CCA's are located on top of the rotary storage drum assembly to provide information about current drum location. Data is routed to the CPU CCA via the Sensor #1 CCA.

- **Drum Gray Code Sensor CCA** – detects the general stopping position and current rotary storage drum face (A to D). Drum face is determined by two photo sensors and a special shutter located on the drum shaft.

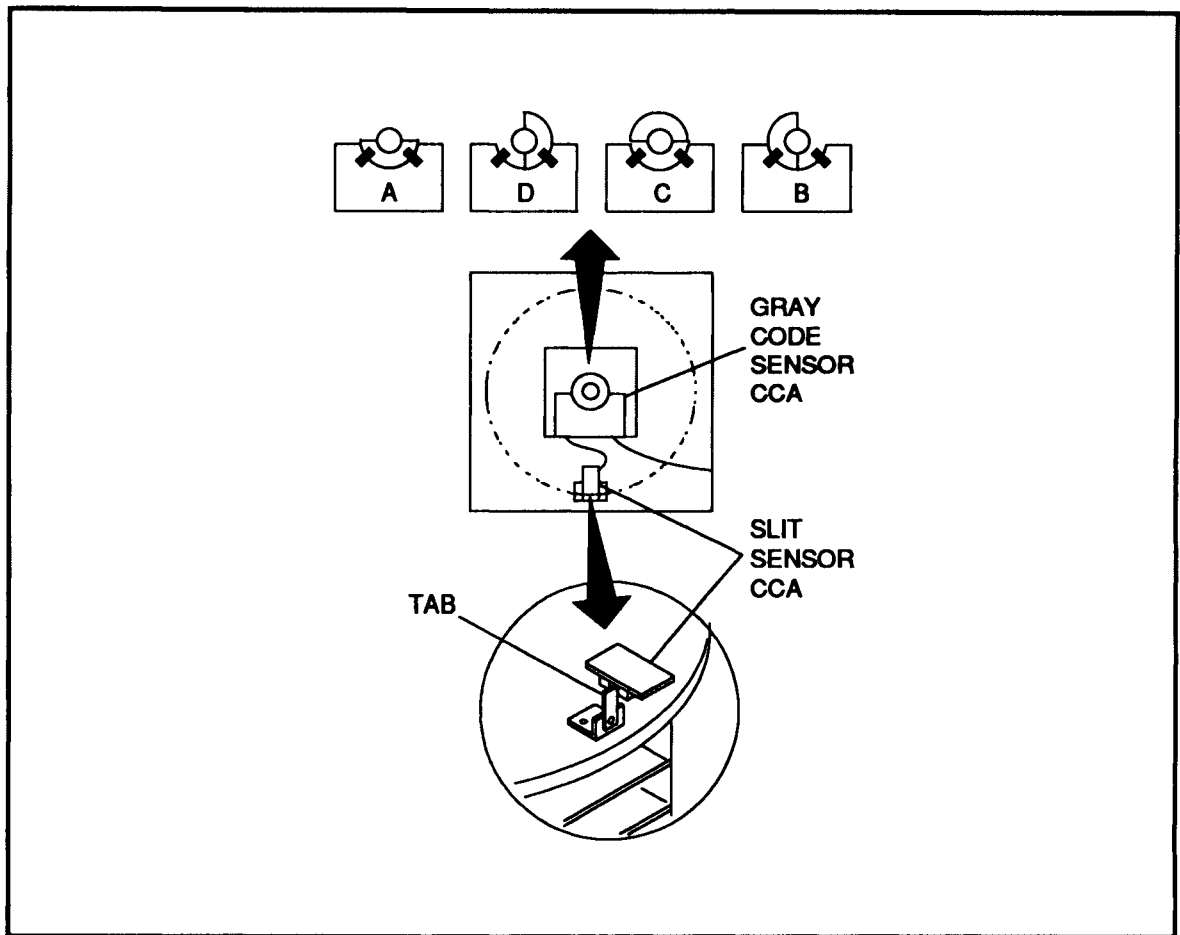

Figure 4-4. Drum Sensors Operation

This CCA has 3 LED's that perform the following functions.

**NOTE** See Section 5 for location and additional descriptions of the LED's and switches.

- SLIT LED (D1) – indicates when a drum face is positioned forward.
- FACE LED's (D2 to D3) – indicates which drum face is currently forward.
- **Drum Slit Sensor CCA** – detects the precise stopping position of the rotary storage drum face. Position is determined by a single photo sensor detecting one of four tabs mounted on the top of the drum at each face.

#### 4.3.4. ELEVATOR BLOCK

Figures 4-5 and 8-1 depict the assemblies discussed in the following paragraphs.

The Elevator Block contains the modules, motors, and physical hardware assemblies required to move the handler assembly up and down (Y-axis) to each bin position of the rotary storage drum and the tape drive(s).

Physically, the elevator is mounted on two roller bearing assemblies allowing it to move easily up or down the side rails of the Cartridge Loader Assembly. The elevator pulse motor is mounted on top of the Cartridge Loader Assembly, and is attached to both sides of the elevator using two drive belts. The high torque stepper motor provides the precise movement control required.

Control over motor speed, duration, and direction is provided by the CPU CCA via the Pulse Motor Controller #2 CCA and Pulse Motor Driver #2. Sensors located on the side of the elevator provide current position information.

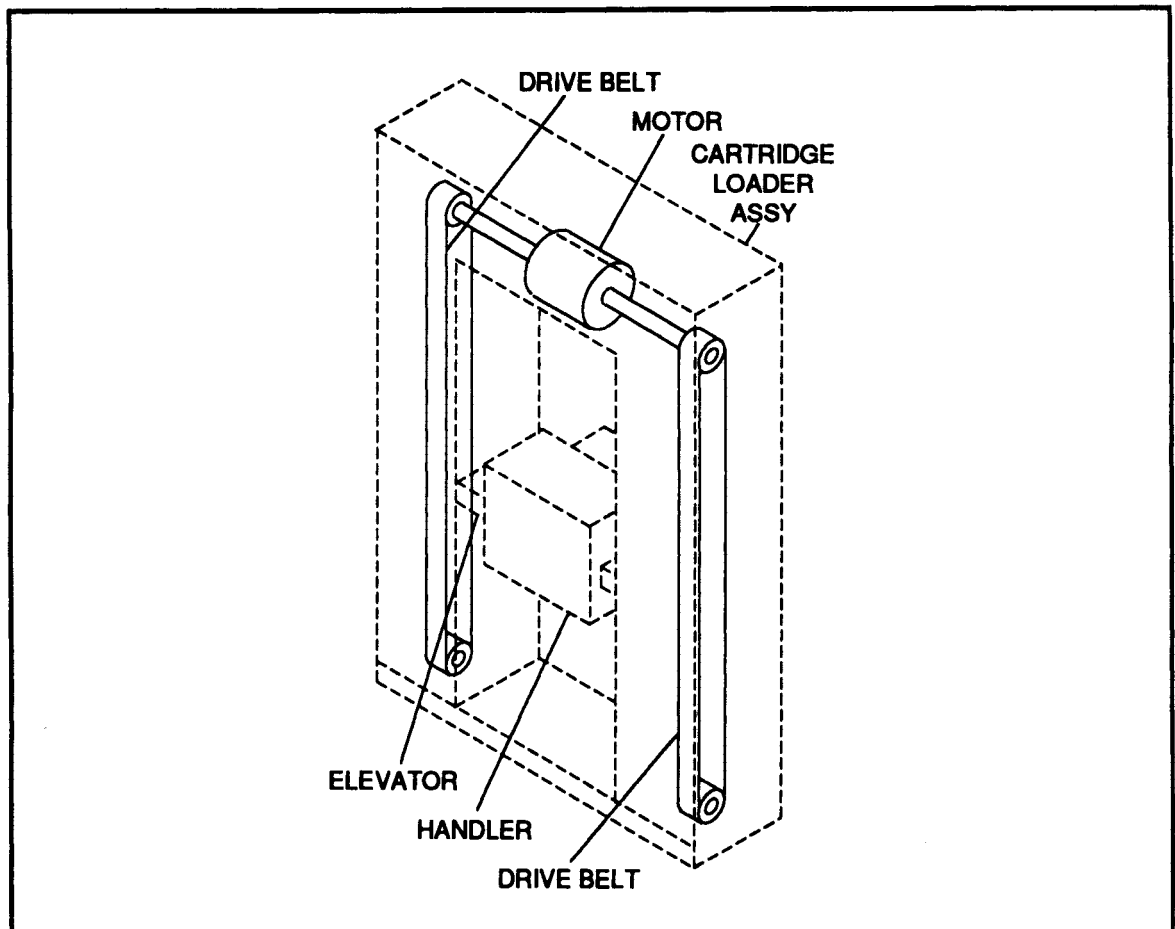

Figure 4-5. Elevator Operation

This block is comprised of the following replaceable assemblies and modules:

- Pulse Motor Driver #2 Module
- Elevator Pulse Motor Assembly
- Elevator Sensor CCA

#### 4.3.4.1. Pulse Motor Driver #2 Module

The Pulse Motor Driver #2 module provides the high current to drive the five phases of the elevator stepper motor. Maximum current is adjustable to 1.4 amps. Control over speed, direction, and duration is determined by the pulse input provided by Pulse Motor Controller #2 CCA. Drive is provided by 100 Vac from the Power Supply Block only when the front door is closed. Refer to Figure 4-3 for more information.

#### 4.3.4.2. Elevator Pulse Motor

The Elevator Pulse Motor is a hybrid five phase stepper motor that moves the elevator in precisely controlled 0.36° steps.

The stepper motor provides 1,000 steps per revolution. The motor is driven by a five-phase drive current provided by the Pulse Motor Driver #2 module under control of Pulse Motor Controller #2 CCA.

#### 4.3.4.3. Elevator Sensor CCA

The Elevator Sensor CCA is located on the left side of the elevator assembly, and contains two sensors that provide information about current elevator location. Data is routed to the CPU CCA via the Sensor #1 CCA.

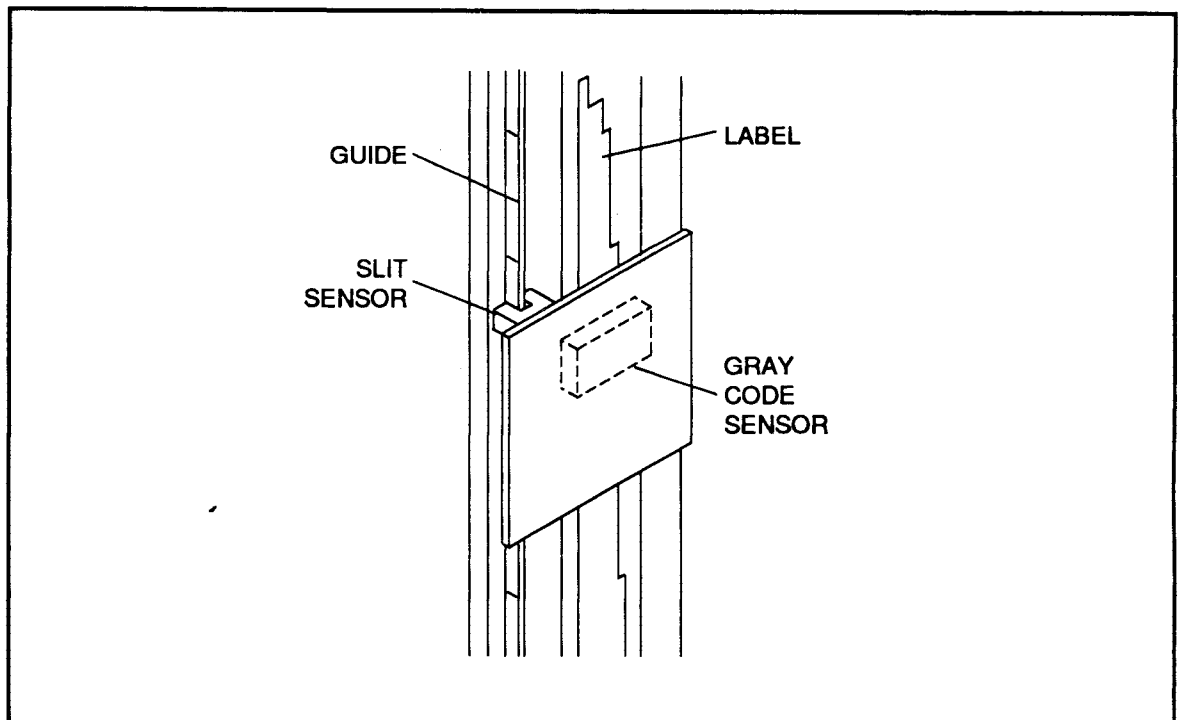

Figure 4-6. Elevator Sensor Operation

- **Elevator Gray Code Sensor CCA** – detects the general stopping position and current bin number (01-12) or tape drive number (1-2). Position is determined by reflective photo sensors and a special coded label located on the left side vertical guide frame.
- **Elevator Slit Sensor CCA** – detects the precise stopping position of the elevator at each bin/drive. Position is determined by a single photo sensor detecting one of 14 tiny slits notched out on a vertical guide mounted on the left side.

### 4.3.5. HANDLER BLOCK

Figures 4-7, 4-8, and 8-1 depict the assemblies discussed in the following paragraphs.

The Handler Block contains the CCA's, modules, motors, and physical hardware assemblies required to move the data cartridge in and out (Z-axis) of the rotary storage drum bins and tape drive(s).

Physically, the handler is comprised of a movable carriage mounted on a fixed chassis.

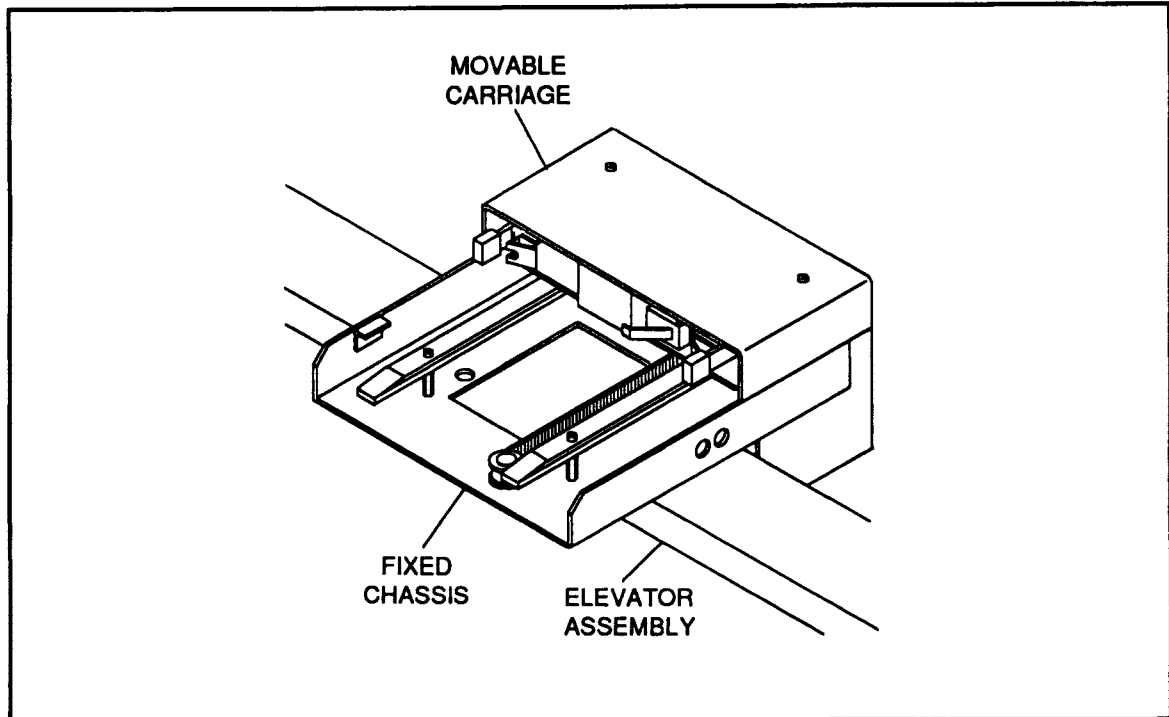

Figure 4-7. Handler Components

- The movable carriage contains the components required to grab and hold the data cartridge. Special spring loaded arms with rubber fingers attached are used to grab and hold the side of the data cassette. A solenoid is activated by 24 Vdc from the Drive and I/O CCA in the Control Block to expand the fingers either prior to grabbing, or when releasing the data cartridge.
- The fixed chassis contains two slides that support the weight of the data cartridge while in the handler. A DC motor is used to move the carriage. This chassis also houses the bar code reading, motor drive, power conditioning, and sensor/ detection circuitry required for handler operations.

The entire handler assembly is attached to the elevator assembly allowing access to all twelve levels of the rotary storage drum and both tape drives.

This block is comprised of the following assemblies and modules:

**NOTE** The only replaceable item in the handler assembly is the Z Motor, the Driver CCA, cables, and drive belt. The CCA's that comprise the drive and bar code reader are not field replaceable.

- Z-Motor Circuitry
- Position/Detection Circuitry
- Bar Code Reader Circuitry

### 4.3.5.1. Z-Motor Circuitry

The Z Motor circuitry consists of the Z Motor and a Driver CCA that provides the Z-axis (in and out) movement of the handler carriage. Control over direction and duration is determined by the CPU CCA via the Sensor #2 CCA in the Control Block. Actual voltage that drives the motor is  $\pm 12$  Vdc.

### 4.3.5.2. Position/Detection Circuitry

The position and detection circuitry consists of three Sensor CCA's and a sensor switch used to determine carriage position and data cartridge presence. Data is routed to the CPU CCA via the Sensor #2 CCA.

- Sensor CCA's – determine if the carriage is full forward (away from the drum), at the mid point, or full backward (closest to the drum). Position is determined by photo sensors and a tab located on the carriage frame.
- Cartridge Switch – closes when a data cartridge is loaded in the handler.

### 4.3.5.3. Bar Code Reader Circuitry

The bar code reader circuitry consists of an illuminating LED, a CCD Camera Assembly, a Reader CCA, and a Decoder CCA used to read bar code labels affixed to data cartridges.

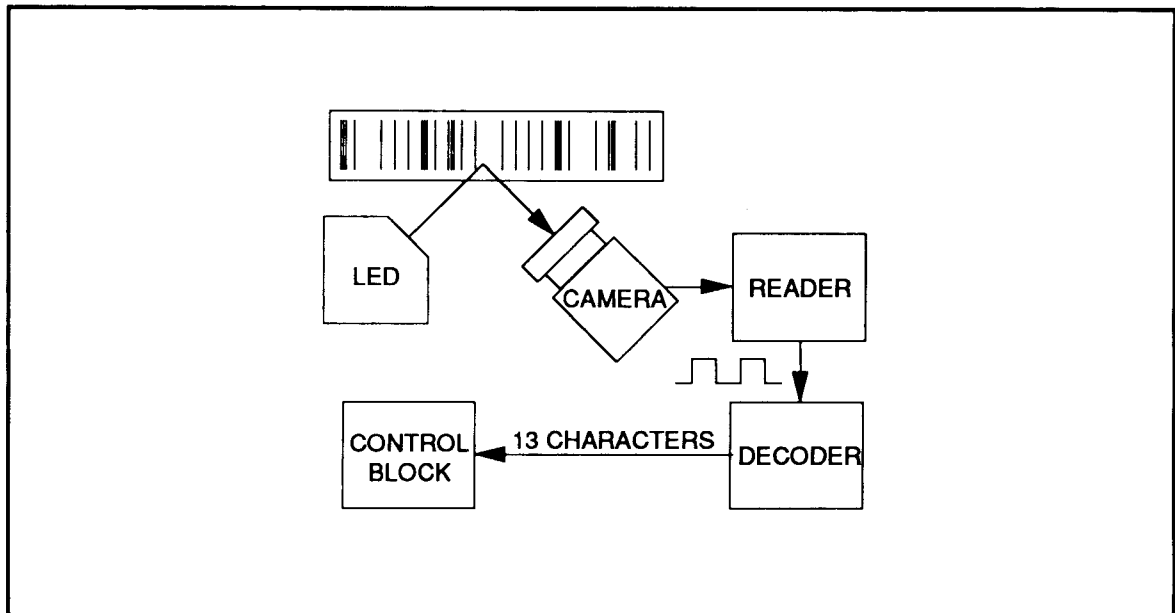

Figure 4-8. Bar Code Read Operation

Operating under control of the CPU CCA via the Sensor #2 CCA, the illuminating LED is turned on allowing the CCD Camera to read the bar code label. Once read, the information is decoded and up to 13 characters are routed to the Control Block.

The Bar Code Reader and Decoder CCA's have two LED's that perform the following functions.

**NOTE** See Section 5 for location and additional descriptions of the LED's.

- READER CCA LED (D1) – indicates that a bar code can be read.
- DECODER CCA LED (D5) – indicates that a data cartridge is located directly in front of the handler assembly.

## **4.3.6. POWER SUPPLY BLOCK**

Figure 8-1 depicts the assemblies discussed in the following paragraphs.

The Power Supply Block contains the modules and components that provide the internal ac and dc operating voltages used for RSS-48b operations.

Input AC power of 100, 117, 220, or 230 Vac is routed to the the modules in the Power Supply Block via one 20 amp non-resetting circuit breaker. A second 20 amp circuit breaker routes input power to the tape drives. Both these circuit breakers also act as power switches for the RSS-48b. Line conditioning is provided by three line filters.

This block is comprised of the following replaceable assemblies and modules:

- Power Transformer
- Power Supply #1 Module
- Power Supply #2 Module
- Power Supply #3 Module

### **4.3.6.1. Power Transformer**

The Power Transformer circuit converts the AC input voltage of 100, 117, 220, or 230 Vac to 100 Vac. The 100 Vac is used by the Power Supplies, and Pulse Motor Drivers in the Drum and Elevator Blocks. Also included on the power transformer is a jumper to select input line voltage. A relay actuated by the front door switch removes 100 Vac from the Pulse Motor Drivers and +24Vdc Power Supply when the front door is opened.

### **4.3.6.2. Power Supply #1 Module**

Power Supply #1 converts the AC input power of 100 Vac from the power transformer to +5 Vdc, and  $\pm 12$  Vdc.

- +5 Vdc at 5 amp is not used.
- +12 Vdc at 3 amp is provided for analog circuitry.
- -12 Vdc at 0.3 amp is provided for analog circuitry.

Power distribution is accomplished by the Motherboard CCA.

### **4.3.6.3. Power Supply #2 Module**

Power Supply #2 converts the AC input power of 100 Vac from the power transformer to +5 Vdc at 20 amps for the digital circuitry.

Power distribution is accomplished by the Motherboard CCA.

### **4.3.6.4. Power Supply #3 Module**

Power Supply #3 converts the AC input power of 100 Vac from the power transformer to +24 Vdc at 4.5 amp for high current analog circuitry including the solenoid, fan, and Z-motor. A relay actuated by the front door switch removes 100 Vac from the +24Vdc Power Supply when the front door is opened.

Power distribution is accomplished by the Motherboard CCA.

# 5. SERVICE

---

## 5.1. GENERAL

This section describes preventive and corrective maintenance for the RSS-48b. Service oriented preventive maintenance consists of replacing items at specific intervals that are subject to failure over time. Corrective maintenance includes troubleshooting, repair and replacement of parts, and post-repair adjustment/calibration procedures.

### WARNING

These service instructions are for use by qualified personnel only. To avoid electric shock, do not remove covers or perform procedures unless you are qualified to do so.

### WARNUNG

Diese Bedienungsanleitung ist ausschließlich für qualifiziertes Personal bestimmt. Um einen elektrischen Schlag zu vermeiden, darf nur qualifiziertes Personal Abdeckungen entfernen oder Arbeiten durchführen.

### AVERTISSEMENT

Ces instructions de service s'adressent à du personnel compétent seulement. Pour éviter tout choc électrique, ne retirez pas les garnitures et n'entrez aucune procédure à moins d'être qualifié pour le faire.

### CAUTION

This equipment contains ESDS devices. Proper ESDS device handling procedures must be followed. Refer to the ESDS DEVICE HANDLING information at the front of this manual.

### NOTE

This manual contains the information required to repair the RSS-48b only to the lowest field replaceable unit, as determined by the manufacturer. This repair philosophy is basically a module exchange, with some individual high-wear parts included.

### NOTE

An RSS-48b service training program is available upon request. This course is strongly recommended prior to servicing the RSS-48b. Contact your Distributor for more information.

## 5.2. SAFETY PRECAUTIONS

### 5.2.1. ELECTRICAL SAFETY

#### WARNING

The RSS-48b contains dangerous high voltages. CARELESS OR IMPROPER HANDLING CAN RESULT IN SERIOUS ELECTRIC SHOCK. Never perform maintenance with power applied unless absolutely necessary.

#### WARNUNG

Die RSS-48b enthält gefährliche Hochspannungen. UNACHTSAME ODER UNSACHGEMÄSSE HANDHABUNG KANN ZU ERNSTHAFTEM ELEKTRISCHEM SCHOCK FÜHREN. Niemals Wartungsarbeiten bei eingeschaltetem Strom durchführen, es sei denn absolut notwendig.

#### AVERTISSEMENT

Le RSS-48b contient des composants sous haute tension dangereux. UNE MANIPULATION INADÉQUATE OU NE RESPECTANT PAS LES PRÉCAUTIONS VOULUES PRÉSENTE DE GRAVES RISQUES D'ÉLECTROCUTION. Ne jamais effectuer l'entretien quand l'unité est sous tension.

When performing maintenance or adjustments with power applied, observe the following precautions.

- Ensure that the RSS-48b chassis and test equipment chassis are connected to earth ground, except where specifically noted.
- Restrict the test area to qualified technicians.
- Remove all metal objects from your person.
- Use an insulated adjustment tool for making adjustments.
- Avoid placing any part of your body in close proximity to any high voltage area.
- After turning the power off, wait for the high voltages to discharge. Each power supply should drain off all power in one minute when all modules are properly installed.

## 5.3. TOOLS AND TEST EQUIPMENT

### 5.3.1. TEST EQUIPMENT

Table 5-1 provides a list of recommended test equipment for use when performing RSS-48b maintenance. Equivalent test equipment is required to make the measurements and comparisons necessary in adjusting and troubleshooting the RSS-48b.

### 5.3.2. SPECIAL TOOLS

The special tools required to maintain the RSS-48b are listed below:

- Spring scale, compression type, 5-10 pounds (2.2-4.5 kg).
- 36-pin CCA extender card (P/N 650475).

### 5.3.3. COMMON TOOLS

Table 5-1 provides a list of recommended common tools for use when performing RSS-48b maintenance.

Table 5-1. Required Equipment

DESCRIPTION	USE*
Digital Multimeter (0-250 Vdc/Vac/ $\Omega$ , $\pm 0.001V$ accuracy)	T, A
Oscilloscope (25 MHz general purpose w/probes)	T, A
PC compatible Computer w/RS-232 Comm program and one free serial port or dumb terminal w/w/RS-232 port	T
Flat Bladed Screwdriver	R
Hex-drive set (2.4 mm to 4 mm)	R
Open end wrench set (3/8 to 5/8)	R
Open end wrench set (4 mm to 11 mm)	R
Phillips Screwdriver	R
Compression type Spring scale, 5-10 pounds (2.2-4.5 kg).	R
* T=Troubleshooting, A=Adjustment, R=Remove/Replace	

## 5.4. PREVENTIVE MAINTENANCE

### 5.4.1. SCHEDULED PROCEDURES

Preventive maintenance is broken down into two different classes as follows:

- **Operator's Preventive Maintenance:** These are the regularly scheduled inspections and cleaning needed to maintain the RSS-48b. Refer to Section 3 for Operator's Preventive Maintenance procedures.
- **Service Preventive Maintenance:** This is the scheduled replacing of key items that are subject to failure over time. Table 5-2 contains the list of items, recommended time intervals, and a reference to the instructions in this manual that contain the procedures. The recommended time intervals are to be considered maximum. Heavy usage, adverse conditions, or local maintenance procedures may dictate more frequent inspections.

**WARNING**

Always disconnect power from the RSS-48b before performing any preventive maintenance.

**WARNUNG**

Vor der Durchführung von vorbeugenden Wartungsarbeiten immer die Stromzufuhr der RSS-48b abschalten.

**AVERTISSEMENT**

Toujours mettre le RSS-48b hors tension avant d'effectuer tout entretien préventif.

Table 5-2. Preventive Maintenance Procedures

INTERVAL	ITEM	ACTION	MANUAL REFERENCE
6 Months	Rubber Fingers  Drive Belts – Elevator (all four)  – Drum  – Handler	Replace  Adjust	See paragraph 5.6.1.15.1 for procedure.  See paragraphs 5.6.1.16.4 and 5.6.1.16.5 installation step 4 for procedures. See paragraph 5.6.1.14.1 installation step 2 for procedure. See paragraph 5.6.1.15.7 installation step 3 for procedure.
12 - 18 Month	Z Motor  Z Motor Driver Pulse Motor Drivers Solenoid Bar Code Reader	Replace  Adjust Adjust Adjust Adjust	See paragraph 5.6.1.15.6 for procedure. See paragraph 5.7 for procedure. See paragraph 5.7 for procedure. See paragraph 5.7 for procedure. See paragraph 5.7 for procedure.
5 Years	Drive Belts – Elevator (all four)  – Drum  – Handler  50-pin Cable Assy	Replace    Replace	See paragraphs 5.6.1.16.4 and 5.6.1.16.5 for procedures. See paragraph 5.6.1.14.1 for procedure. See paragraph 5.5.6.1.15.7 for procedure. See paragraph 5.6.1.16.2 for procedure.
-----	Tape Drive	Clean Transport	Instructions are provided in the Operator's Manual or User's Guide provided with the tape drive.
As required	Tape Drive	Repair/Exchange	Refer to paragraph 2.7.2 for procedure.

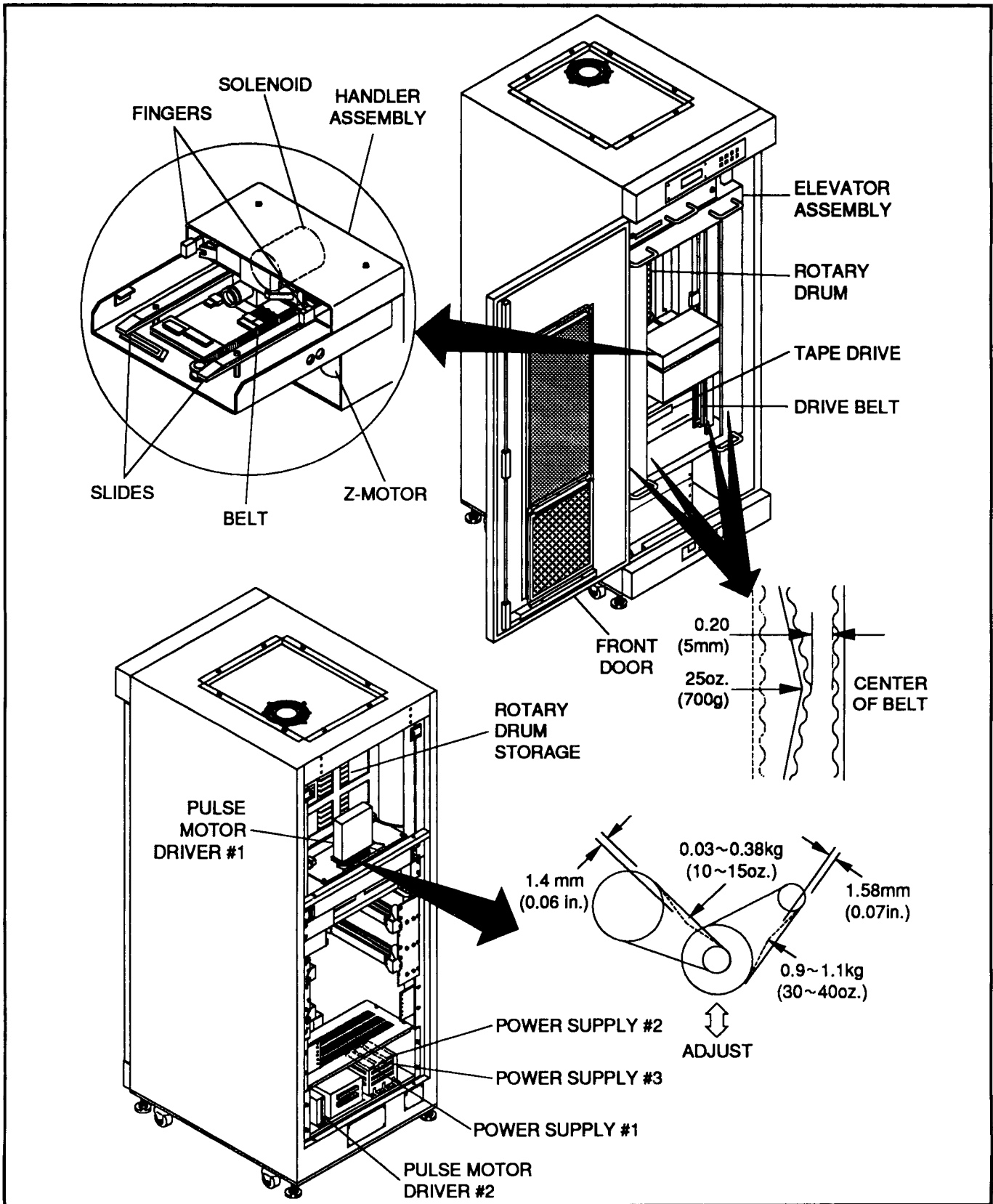

Figure 5-1. Preventive Maintenance

## 5.5. TROUBLESHOOTING

**NOTE** This manual contains the information required to repair the RSS-48b only to the lowest field replaceable unit, as determined by the manufacturer. This repair philosophy is basically a module exchange, with some individual high-wear parts included.

Faults are isolated in the RSS-48b by evaluating error codes and/or current symptoms, and then checking each functional system involved to locate the malfunctioning part.

A thorough understanding of the theory of operation, as described in Section 4, will aid the technician in solving problems. Also, the functional block and interconnect diagrams in Section 8 will assist you when troubleshooting the RSS-48b. Approach each problem in a logical manner, utilizing both practical and theoretical troubleshooting principles.

Table 5-3 contains the checks to be performed when troubleshooting the RSS-48b to the defective module, assembly, or subassembly. Once a malfunction has been isolated, the defective part is replaced. See Repair and Replacement Procedures (paragraph 5.6) for more information.

Prior to troubleshooting, perform a complete and thorough visual inspection.

Inspect for:

- correct jumper configuration
- correct switch settings
- damaged parts
- evidence of abnormal heat
- faulty circuit breakers
- loose cable connectors
- loose circuit cards
- loose components
- loose external signal connectors
- loose hardware
- loose wires
- missing parts
- unseated components

## 5.5.1. TROUBLESHOOTING HINTS

### 5.5.1.1. CCA LED's

Most of the CCA's and modules in the RSS-48b have LED's to indicate if certain conditions or outputs are present. Assembly LED locations and indications are illustrated in Figure 8-5. LED functions are as follows:

#### 5.5.1.1.1. CPU CCA (Slot #1)

CPU CCA LED's indicate the following status (see Figure 8-5 for location):

- **R/W LED (D001)** – indicates the transfer direction (R/W) of the microprocessor. ON is a READ operation, OFF is a WRITE operation. LED is normally ON.
- **SYNC LED (D002)** – When ON, a microprocessor fetch operation is being executed. OFF indicates a CPU malfunction.
- **NMI LED (D003)**: When ON a non-maskable external interrupt is being received. OFF indicates a CPU malfunction.

#### 5.5.1.1.2. Sensor 1 CCA (Slot #2)

Sensor 1 CCA LED's indicate the following status (see Figure 8-5 for location):

- **ELEVATOR SLIT LED (D002)** – When OFF, the elevator is correctly positioned. When ON, the elevator is not at its desired position.
- **ELEVATOR GRAY 6 to 2 LED's (D003 to D007)** – indicates the current rotary storage drum-bin or tape drive number. See Figure 8-5 for the 14 different LED configurations.
- **DRUM SLIT LED (D009)**: When ON, the rotary storage drum is correctly positioned. When OFF, the drum is not at its desired position.
- **DRUM GRAY 1 & 2 LED's (D011 and D012)** – indicates the current rotary storage drum-face number. See Figure 8-5 for the four different LED configurations.
- **CPU NG LED (D013)** – When ON, the CPU CCA microprocessor is malfunctioning (runaway). This LED is normally OFF.

Table 5-3. RSS-48b Troubleshooting

SYMPTOM	CAUSE	CORRECTIVE ACTION
RSS-48b will not power-up.	Numerous Items	Troubleshoot using the information provided in Figure 8-6, "AC POWER PROBLEM".
RSS-48b powers-up but not properly.	Numerous Items	Troubleshoot using the information provided in Figure 8-6, "NO INITIALIZATION".
Display problems.	Numerous Items	Troubleshoot using the information provided in Figure 8-7, "DISPLAY PROBLEMS".
Pushbutton problems	Numerous Items	Troubleshoot using the information provided in Figure 8-7, "OPERATION PANEL PROBLEMS".
Communication problems.	Numerous Items	Troubleshoot using the information provided in Figure 8-8, "COMMUNICATION PROBLEMS".
Displays or returns ERROR CODE.	Numerous Items	Troubleshoot using the information provided in Table 5-4.

Table 5-4. Error Message Troubleshooting

ERROR	PROBLEM AREA	CORRECTIVE ACTION
OG2>	Rotary Storage Drum	Troubleshoot using the information provided in Figure 8-9. Match symptoms with correct tree.
OG3>	Elevator	Troubleshoot using the information provided in Figure 8-10. Match symptoms with correct tree.
OG5>	Handler	Troubleshoot using the information provided in Figure 8-11. Match symptoms with correct tree.
OL2>	Door Interlock Circuitry	1. Verify that the front door is closed. 2. Troubleshoot using the information provided in Figure 8-1 and 8-2.
ON1>	Data Cartridge Removal	1. Verify handler does not already have a cartridge loaded. 2. Verify a data cartridge exists in front of the handler. 3. Troubleshoot using the information provided in Figure 8-12.
ON2>	Data Cartridge Insertion	1. Verify handler has a cartridge loaded. 2. Verify a data cartridge does not exist in front of the handler. 3. Troubleshoot using the information provided in Figure 8-12.
ON6>	RS-232 Command Incorrect	Send correct command (refer to Section 3).

### 5.5.1.1.3. Sensor 2 CCA (Slot #3)

Sensor 2 CCA LED's indicate the following status (see Figure 8-5 for location):

- **BAR READ LED (D1)** – When ON (very hard to detect), a Bar Code Read Command (1 or 2) is being executed.
- **Z-DIRECTION LED (D6)** – When ON, the carrier is moving away from rotary storage drum/tape drive.
- **Z-ON/OFF LED (D7)** – When ON, the Z-axis motor is operating. When OFF, the Z-axis motor is stationary.
- **Z-MOTOR N.G. LED (D17)** – When ON, the Z-axis motor is drawing excessive current. This LED is normally OFF.
- **CASSETTE SWITCH LED (D18)** – When ON, a data cartridge is fully loaded in the handler.
- **Z-FRONT LED (D22)** – When ON, the carriage is in the full forward position.
- **Z-MIDDLE LED (D23)** – When ON, the carriage is in the middle position.
- **Z-BACK LED (D24)** – When ON, the carriage is in the full rear position.
- **BAR DETECT LED (D25)** – When ON, a data cartridge is loaded in the handler. When OFF, a data cartridge is directly in front of the handler.
- **FRONT DOOR OPEN LED (D28)** – indicates that the front door is open.
- **ALARM RESET SWITCH and KEY 0-2 LED's (D29 to D32)** – indicates that one of the front panel pushbuttons is being pressed. See Figure 8-5 for the nine different LED configurations.

### 5.5.1.1.4. Drive and I/O CCA (Slot #4)

Drive and I/O CCA LED's indicate the following status (see Figure 8-5 for location):

- **ALARM 1 LED (D1)** – When ON, the system error alarm (0) is active. This LED is normally OFF.
- **ALARM 2 LED (D12)** – When ON, user defined error alarm (1) is active. This LED is normally OFF.
- **ALARM 3 LED's (D13)** – When ON, user defined error alarm (2) is active. This LED is normally OFF.
- **PLUNGER OPEN LED (D2)** – When ON, the handler's solenoid plunger is energized, causing the fingers to open.  
**ALARM LED (D3)** – When ON, the ALARM pushbutton LED is on.
- **BAR CODE READ LED (D4)** – When ON, the BAR CODE READ pushbutton LED is on.
- **ELEVATOR DOWN LED (D5)** – When ON, the DOWN pushbutton LED is on.
- **CASSETTE EJECT (D6)** – When ON, the EJECT pushbutton LED is on.
- **ELEVATOR UP LED (D7)** – When ON, the UP pushbutton LED is on.
- **CASSETTE INJECT (D8)** – When ON, the INJECT pushbutton LED is on.
- **DRUM-TURN RIGHT LED (D9)** – When ON, the RIGHT pushbutton LED is on.
- **DRUM-TURN LEFT LED (D10)** – When ON, the LEFT pushbutton LED is on.

#### 5.5.1.1.5. FIP I/O CCA (Slot #7)

FIP I/O CCA LED's indicate the following status (see Figure 8-5 for location):

- **BLANK LED (D1)** – When ON, display is blanking during power-up. This LED is OFF for normal operation.
- **GATE LED (D2)** – When OFF, display is initializing during power-up. This LED is ON for normal operation.
- **FRAME LED (D3)** – When ON, display is operating normally.

#### 5.5.1.1.6. Pulse Motor Controller CCA (Slots #8 and #9)

Pulse Motor Controller CCA LED's indicate the following status (see Figure 8-5 for location):

- **CPU NG LED (D2)** – When ON, the CPU CCA microprocessor and/or this microprocessor are malfunctioning (runaway). This LED is normally OFF.
- **SYNC LED (D3) both CCA's** – When OFF, the CPU CCA microprocessor and/or this microprocessor are malfunctioning (runaway). This LED is normally ON.
- **DRUM SLIT (D5) PM Cont#1** – When ON, the rotary storage drum is rotating.
- **ELEVATOR SLIT (D7) PM Cont#2** – When ON, the elevator is moving.

#### 5.5.1.1.7. Drum Gray Code Sensor CCA

- **FACE LED's (D1 to D3)** – indicates which drum face is currently forward. See Figure 8-5 for the four different LED configurations.

#### 5.5.1.1.8. Bar Code Reader Circuitry

- **READER CCA LED (D1)** – When ON, the bar code directly in front of the handler can be read.
- **DECODER CCA LED (D5)** – When ON, a data cartridge is located directly in front of the handler assembly.

#### 5.5.1.2. CCA SWITCHES

Some of the CCA's in the RSS-48b Control Block have switches that set communication and identification parameters. Assembly switch locations and configurations are illustrated in Figure 8-5. Switch functions are as follows:

- **CPU CCA (Slot #1):** Switch positions perform following functions:
  - S1-1 to 3: Sets baud rate for the RS-232C serial interface port to 300, 1200, or 2400 baud. See Figure 8-5 for switch configurations.
  - S1-4: Selects the termination character for commands received over the RS-232C serial interface port. Open selects a "C", and closed selects a ">".
  - S2: Momentary push button resets the CPU CCA microprocessor to its "power on" state.

- **Sensor 1 (Slot #2):** Switch positions perform following functions:
  - S3-1 & 2: Sets parity for the RS-232C serial interface port to none, even, or odd. See Figure 8-5 for switch configurations.
  - S3-3: Selects the data bit length for the RS-232C serial interface port. Open sets to 7-bit, and closed sets to 8-bit.
  - S3-4 to 8: Not used.
- **Pulse Motor Controller #1 (Slot #8) and #2 (Slot #9):** Switch positions perform following functions:
  - S1-1 to 6: Sets CCA identification as Pulse Motor Controller #1 or #2. See Figure 8-5 for switch configurations.

### 5.5.1.3. CCA JUMPERS

Some of the CCA's in the RSS-48b Control Block have jumpers to configure parameters that are not changed during normal operation. Assembly jumper locations and configurations are illustrated in Figure 8-5. Jumper functions are as follows:

**NOTE** Jumpers are soldered in place and should not be changed unless configuring a CCA for replacement. When replacing a CCA, verify that the jumpers on the replacement CCA are the same as the original CCA.

- **Sensor 1 CCA (Slot #2):** Jumper positions perform following functions:
  - S1-1 to 8: Identification Select. See Normally not changed. See Figure 8-5 for jumper configurations.
  - S2-1 to 8: PIO Address Select. Normally not changed. See Figure 8-5 for jumper configurations.
- **Sensor 2 CCA (Slot #2):** Jumper positions perform following functions:
  - S1-1 to 8: Normally not changed. See Figure 8-5 for jumper configurations.
  - S2-1 to 8: Normally not changed. See Figure 8-5 for jumper configurations.
- **Drive and I/O CCA (Slot #4):** Jumper positions perform following functions:
  - S1-1 to 8: Normally not changed. See Figure 8-5 for jumper configurations.
  - S2-1 to 4: Normally not changed. See Figure 8-5 for jumper configurations.
- **Power Supply #1 Module:** Jumper positions perform following functions:
  - CN2: Input Voltage Select. See Figure 8-5 for jumper configuration.
- **Power Supply #2 Module:** Jumper positions perform following functions:
  - CN3: Input Voltage Select. See Figure 8-5 for jumper configuration.
- **Power Supply #3 Module:** Jumper positions perform following functions:
  - CN3: Input Voltage Select. See Figure 8-5 for jumper configuration.

## 5.6. REPAIR AND REPLACEMENT PROCEDURES

### 5.6.1. DISASSEMBLY AND ASSEMBLY INSTRUCTIONS

Figure 5-2 shows RSS-48b modules, assemblies, and subassemblies used in the replacement procedures.

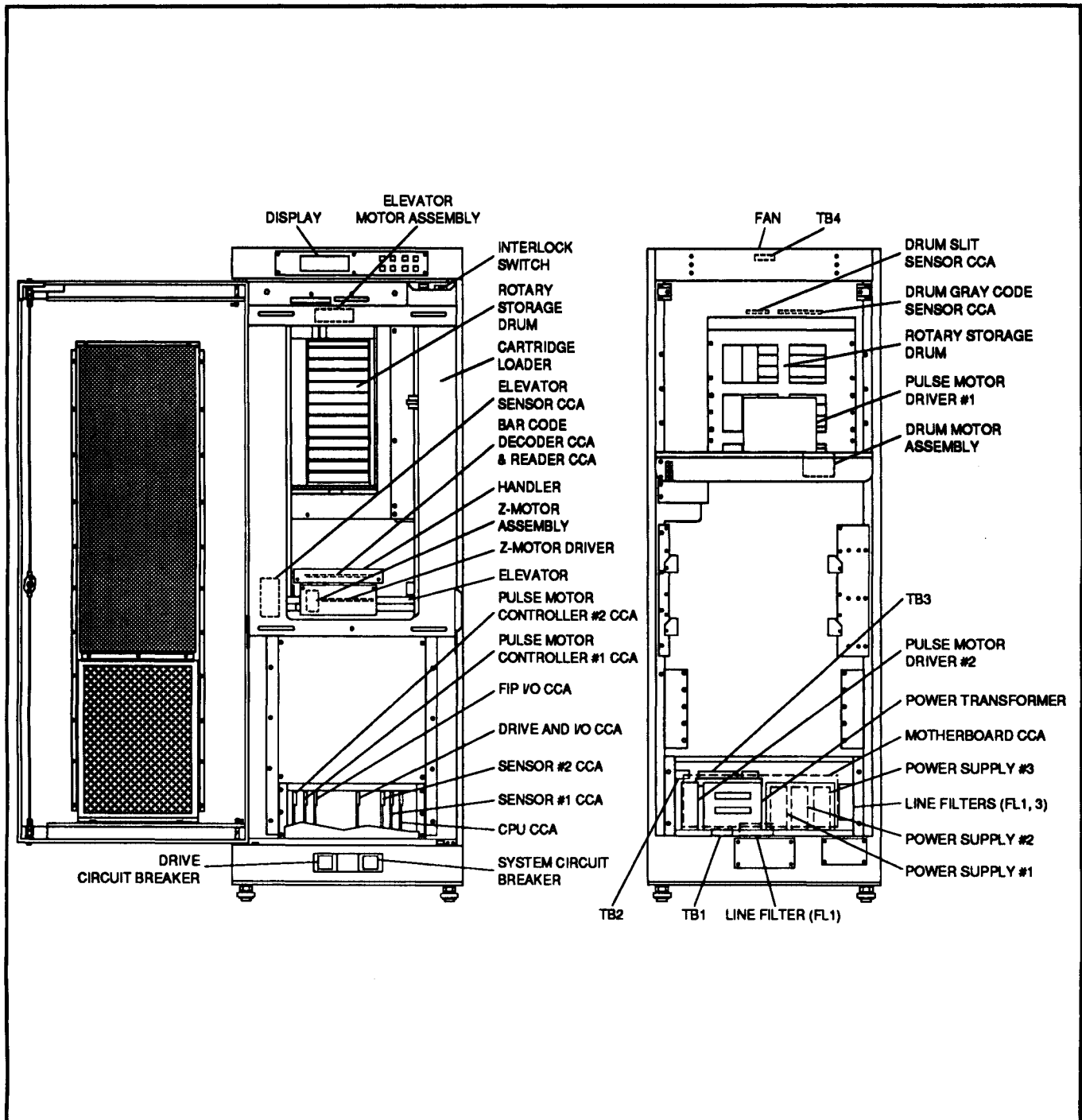

Figure 5-2. RSS-48b Assembly Locator Diagram

### 5.6.1.1. MAINTENANCE ACCESS

Most service functions can be performed with the front door opened, the cartridge loader lowered, and/or the rear panels removed. See Figure 5-3 for the components referenced in the following steps.

#### WARNING

Both electrical shock hazard and mechanical hazard from moving parts exist with the RSS-48b door open or covers removed. Whenever possible, disconnect the RSS-48b from line power before removing covers, and allow one minute for components to discharge.

#### WARNUNG

Sowohl die Gefahr eines elektrischen Schlags als auch die Gefahr durch sich bewegende Teile besteht, wenn die Tür der RSS-48b offen steht oder die Abdeckungen entfernt wurden. Wenn nur eben möglich, die RSS-48b vor dem Entfernen von Abdeckungen abschalten und eine Minute warten, damit sich die Bauteile entladen können.

#### AVERTISSEMENT

Il existe des dangers d'électrocution et des risques de blessures provenant de pièces mécaniques en mouvement lorsqu'on utilise le RSS-48b avec le panneau avant ouvert ou les capots de protection ôtés. Chaque fois qu'il est possible, mettre le RSS-48b hors tension en le débranchant du circuit d'alimentation et laisser les composants se décharger pendant une minute avant d'ôter les capots de protection.

- **Front Door** – Open using ACE® key supplied.

#### WARNING

A minimum of 2 persons are required to perform the next step. If the Cartridge Loader Assembly is allowed to drop uncontrolled, serious bodily injury and/or equipment damage may result.

#### WARNUNG

Mindestens 2 Personen sind zur Ausführung des nächsten Schrittes erforderlich. Wenn die Patronenladeeinheit unkontrolliert fallen gelassen wird, kann das zu ernsthafter Körperverletzung bzw. Geräteschaden führen.

#### AVERTISSEMENT

Il faut au minimum 2 personnes pour effectuer l'opération suivante. Si on laisse tomber l'ensemble de chargeur à cartouche, on s'expose à des blessures et/ou à des dégâts matériels graves.

- **Cartridge Loader** – Loosen the two knurled fastening screws and two hex drive screws, then lower the Cartridge Loader Assembly to the floor. While lowering the Cartridge Loader Assembly, make sure the cable harness on lower left corner is free.

- **Rear Panels** - Remove the top and bottom rear panels by rotating the fasteners until the slot is horizontal then lightly rap the upper corner with the palm of your hand.

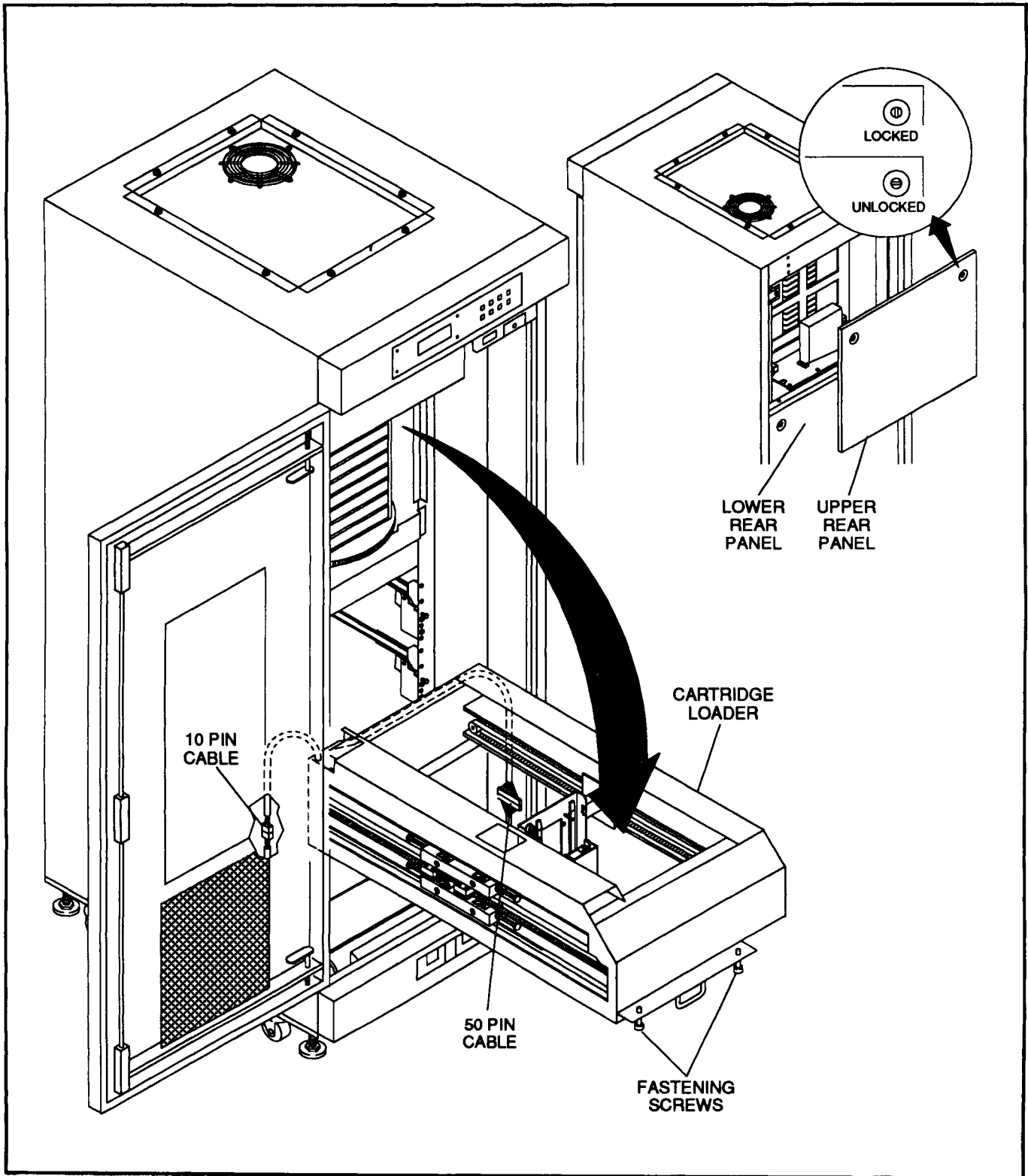

Figure 5-3. RSS-48b Maintenance Access

### 5.6.1.2. FAN

Figure 5-4 illustrates all Fan removal and installation parts.

#### Removal

1. Remove the upper rear panel (refer to paragraph 5.6.1.1).
2. Remove eight screws, and lockwashers retaining the fan panel. Lift fan panel to access fan.
3. Remove four screws, lockwashers, flat washers, and nuts holding the grill and fan.
4. Disconnect 2-pin cable and remove the fan.

#### Installation

1. Install the Fan with air flow directed outward.
2. Complete installation by reversing removal steps 4 through 1.

### 5.6.1.3. DISPLAY ASSEMBLY

Figure 5-4 illustrates all Display Assembly removal and installation parts.

#### Removal

1. Open the front door (refer to paragraph 5.6.1.1).
2. Remove the front dress panel (six screws).
3. Remove four screws, and lockwashers holding the Display brackets.
4. Carefully pull display from cabinet enough to disconnect the following cables:
  - 2 pin cable from J93
  - 30 pin cable from J61
5. Remove the Display Assembly.

#### Installation

1. Install by reversing removal steps 5 through 1.

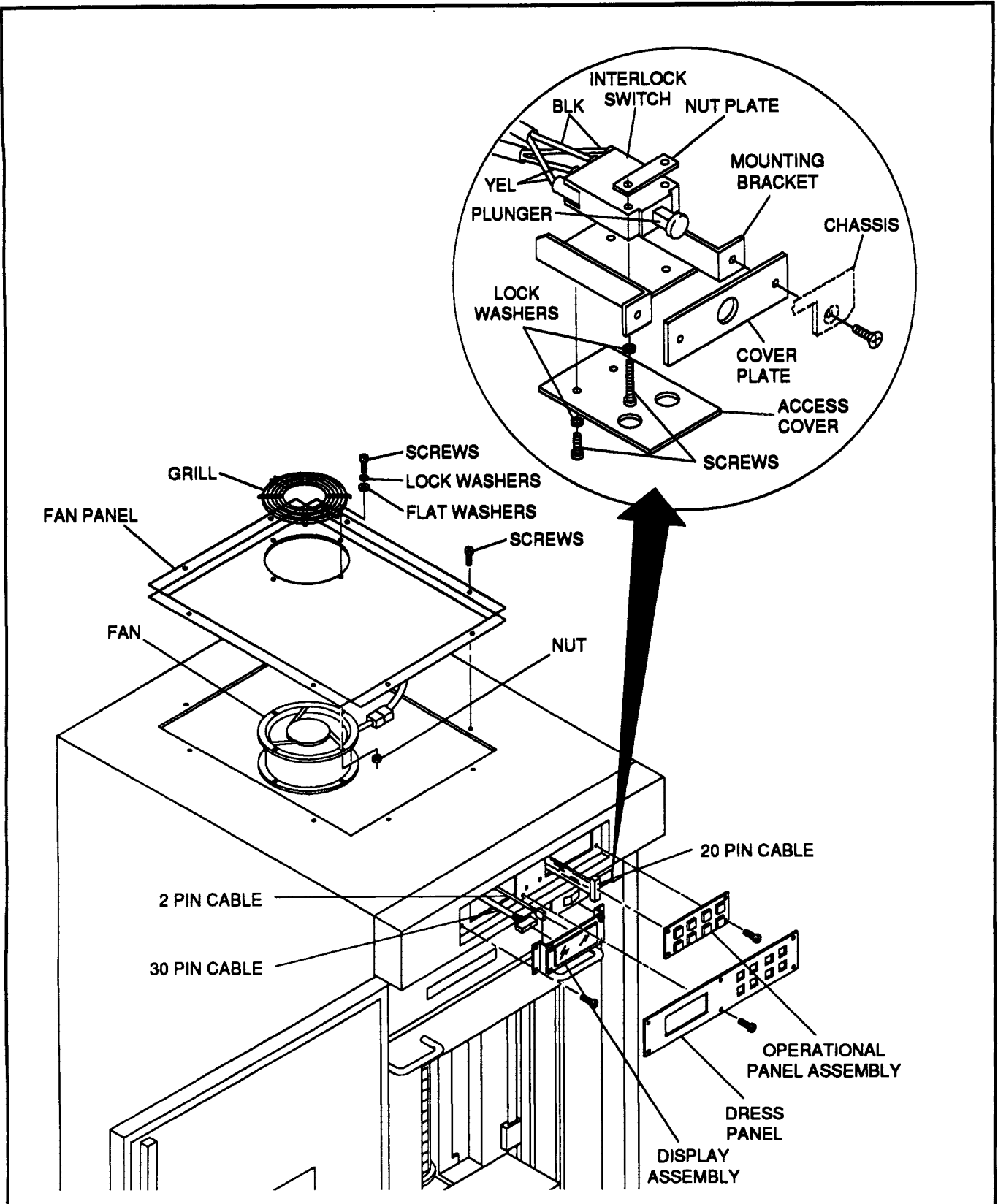

Figure 5-4. Fan, Display, Operational Panel, and Interlock Switch Replacement

#### 5.6.1.4. OPERATIONAL PANEL ASSEMBLY

Figure 5-4 illustrates all Operational Panel Assembly removal and installation parts.

##### Removal

1. Open the front door (refer to paragraph 5.6.1.1).
2. Remove the front dress panel (six screws).
3. Remove four screws, and lockwashers holding the panel.
4. Carefully pull panel from cabinet far enough to disconnect the 20 pin cable from J51.
5. Remove the Operational Panel Assembly.

##### Installation

**NOTE** When reinstalling the front dress panel, make sure ALL the buttons are centered in the panel, and that each key has free movement.

1. Install by reversing removal steps 5 through 1.

#### 5.6.1.5. INTERLOCK SWITCH

Figure 5-4 illustrates all Interlock Switch removal and installation parts.

##### Removal

1. Open the front door (refer to paragraph 5.6.1.1).
2. Remove two flat head screws holding the mounting bracket/ switch/cover plate combination.
3. Remove two screws and lockwashers retaining the access cover to the mounting bracket.
4. Tag and disconnect four wires.
5. Remove switch (two screws, two lockwashers, and one nut plate).

##### Installation

1. Install by reversing removal steps 5 through 1.

### 5.6.1.6. CONTROL CAGE CCA'S

Figure 5-5 illustrates all Control Cage CCA's removal and installation parts.

#### Removal

1. Open the front door (refer to paragraph 5.6.1.1).

#### CAUTION

Each CCA contains ESDS devices. Proper ESDS device handling procedures must be followed. Refer to the ESDS DEVICE HANDLING information at the front of this manual.

2. Remove the circuit card cover (four screws).
3. Pull the CCA from it's slot using the extractors.

**NOTE** If replacing CCA's, record the current position (or occupation) of switch settings and jumpers.

#### Installation

1. Install by reversing removal steps 3 and 1. CCA slot locations are as follows:

Slot #1	CPU CCA
Slot #2	Sensor 1 CCA
Slot #3	Sensor 2 CCA
Slot #4	Drive and I/O CCA
Slot #7	FIP I/O CCA
Slot #8	PM Controller #1 CCA
Slot #9	PM Controller #2 CCA

**NOTE** If installing a replacement CCA, reconfigure switches and jumpers to settings recorded during removal of the old CCA. If unknown, configure as shown in Figure 8-5.

2. If installing a replacement PM Controller CCA, perform Pulse Motor Adjustment (see paragraph 5.7).

### 5.6.1.7. POWER SWITCHES (CIRCUIT BREAKERS)

Figure 5-5 illustrates all Circuit Breaker removal and installation parts.

#### Removal

1. Open the front door (refer to paragraph 5.6.1.1).
2. Remove the cover (four hex drive screws and flat washers).
3. Remove the clear shield (three screws and flat washers).
4. Remove four screws retaining the circuit breaker and pull from cabinet.
5. Tag and disconnect (nut and washer) four wires.
6. Remove the Circuit Breaker.

#### Installation

**NOTE** When reinstalling the Circuit Breaker, ON is towards right.

1. Install by reversing removal steps 6 through 1.

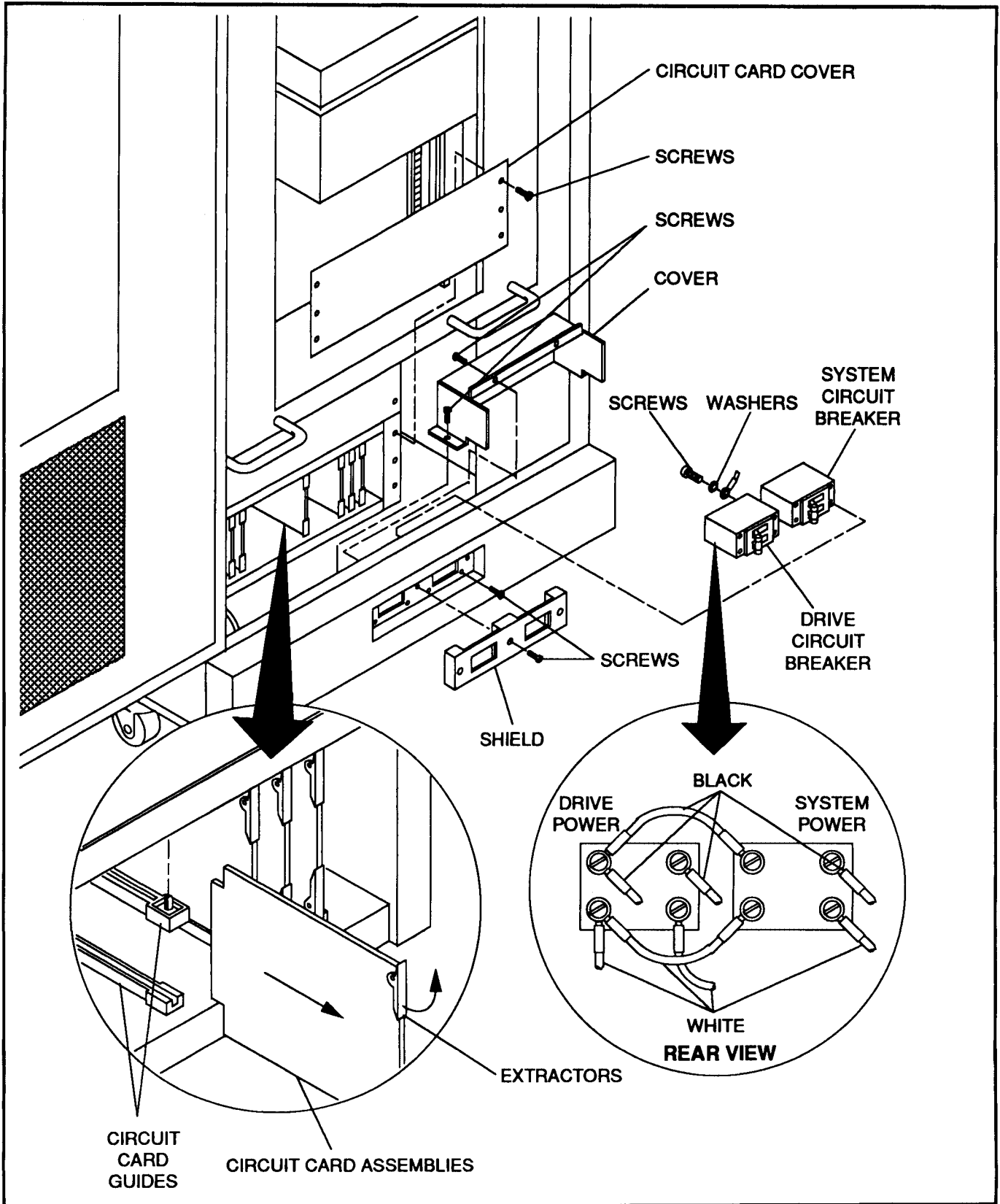

Figure 5-5. Control Cage CCA, Circuit Breaker, and Power Connector Replacement

## 5.6.1.8. LINE FILTERS

Figure 5-6 illustrates all Line Filter removal and installation parts.

### Removal

1. Remove the lower rear panel (refer to paragraph 5.6.1.1).
2. If removing FL1 or FL3 remove Power Supply Modules 1-3 (see paragraph 5.6.1.11 through 5.6.1.13).
3. Remove two screws and lockwashers (for FL1, FL3) or four screws and lockwashers (FL4) holding the line filters.
4. Tag and disconnect (nuts and washers) or unsolder five wires from the desired line filter.
5. Remove the Line Filter.

### Installation

1. Install by reversing removal steps 5 through 1.

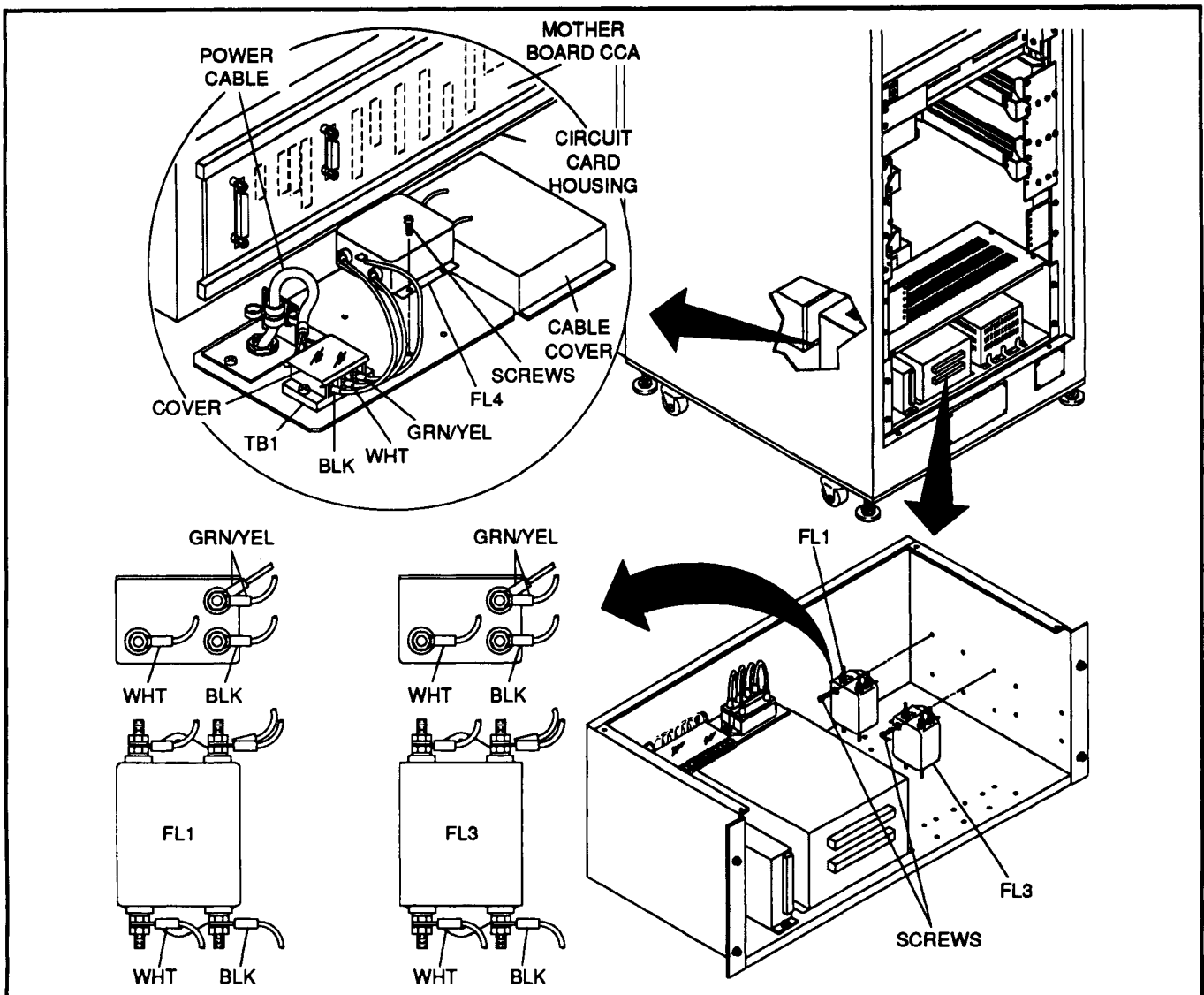

Figure 5-6. Line Filter Replacement

### 5.6.1.9. PULSE MOTOR DRIVER

Figure 5-7 illustrates all Pulse Motor Driver removal and installation parts.

**NOTE** Procedure below is for Pulse Motor Driver #2. Procedure for Pulse Motor Driver #1 is identical, except the Rotary Storage Drum must first be removed (paragraph 5.6.1.14).

#### Removal

1. Remove the lower rear panel (refer to paragraph 5.6.1.1).
2. If removing the lower Pulse Motor Driver, remove the power chassis cover (four screws and lockwashers).
3. Remove two screws, lockwashers, and flat washers holding the module's base plate.
4. Tag and disconnect 11 wires.
5. Remove the Pulse Motor Driver.

#### Installation

1. Install by reversing removal steps 5 through 1.
2. If installing a replacement module, perform Pulse Motor Adjustment (see para 5.7).

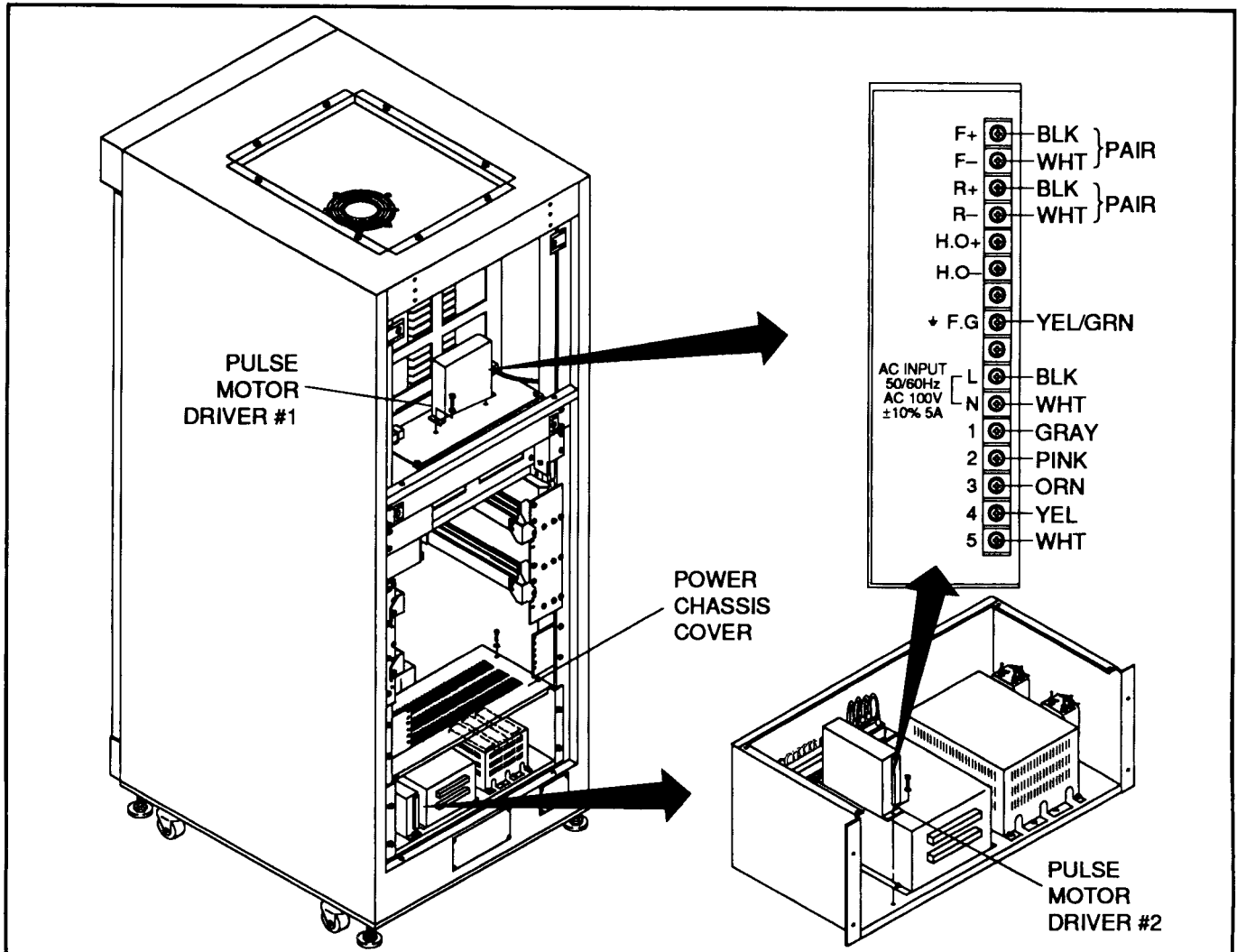

Figure 5-7. Pulse Motor Driver Replacement

### 5.6.1.10. POWER TRANSFORMER

Figure 5-8 illustrates all Power Transformer removal and installation parts.

#### Removal

1. Remove the lower rear panel (refer to paragraph 5.6.1.1).
2. Remove four screws, and lockwashers holding the power chassis cover.
3. Lift the power chassis cover and remove the four hex drive screws, lockwashers, and flat washers holding the power transformer.
4. Tag and disconnect 9 wires.
5. Remove the Power Transformer.

#### Installation

**NOTE** If installing a replacement power transformer, set the voltage selection jumper to the desired position.

1. Install by reversing removal steps 5 through 1.

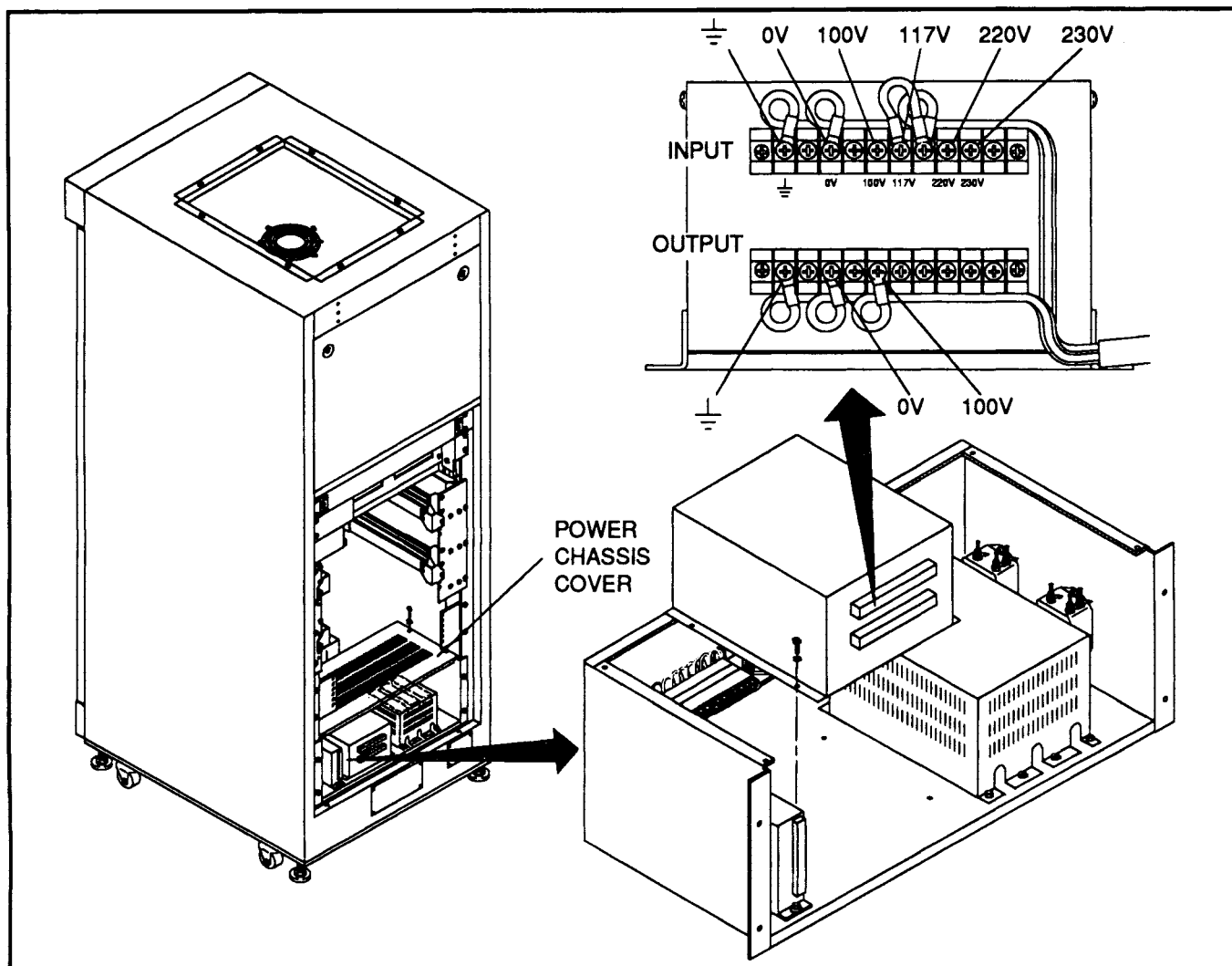

Figure 5-8. Power Transformer Replacement

### **5.6.1.11. POWER SUPPLY #1**

Figure 5-9 illustrates all Power Supply #1 removal and installation parts.

#### **Removal**

1. Remove the lower rear panel (refer to paragraph 5.6.1.1).
2. Remove the power chassis cover (four screws and lockwashers).
3. Remove the power supply cover (eight screws and lock-washers).
4. Remove four screws and lockwashers holding the module's base plate.
5. Disconnect the following cables:
  - 2 pin cable from CN1
  - 8 pin cable from CN3
  - GRN/YEL from GND lug
6. Remove the Power Supply #1.

#### **Installation**

1. Make sure that the jumper at CN2 is in the 100-120V position.
2. Install by reversing removal steps 6 through 1.

### **5.6.1.12. POWER SUPPLY #2**

Figure 5-9 illustrates all Power Supply #2 removal and installation parts.

#### **Removal**

1. Remove the lower rear panel (refer to paragraph 5.6.1.1).
2. Remove the power chassis cover (four screws and lockwashers).
3. Remove the power supply cover (eight screws and lock-washers).
4. Remove four screws and lockwashers holding the module's base plate.
5. Disconnect the following cables:
  - 2 pin cable from CN1
  - 10 pin cable from CN2
  - GRN/YEL from GND lug
6. Remove the Power Supply #2.

#### **Installation**

1. Make sure that the jumper at CN3 is in the 100-120V position.
2. Install by reversing removal steps 6 through 1.

### **5.6.1.13. POWER SUPPLY #3**

Figure 5-9 illustrates all Power Supply #3 removal and installation parts.

#### **Removal**

1. Remove the lower rear panel (refer to paragraph 5.6.1.1).
2. Remove the power chassis cover (four screws and lockwashers).

3. Remove the power supply cover (eight screws and lock-washers).
4. Remove four screws and lockwashers holding the module's base plate.
5. Disconnect the following cables:
  - 2 pin cable from CN1
  - 10 pin cable from CN2
  - GRN/YEL from GND lug
6. Remove the Power Supply #3.

### Installation

1. Make sure that the jumper at CN3 is in the 100-120V position.
2. Install by reversing removal steps 6 through 1.

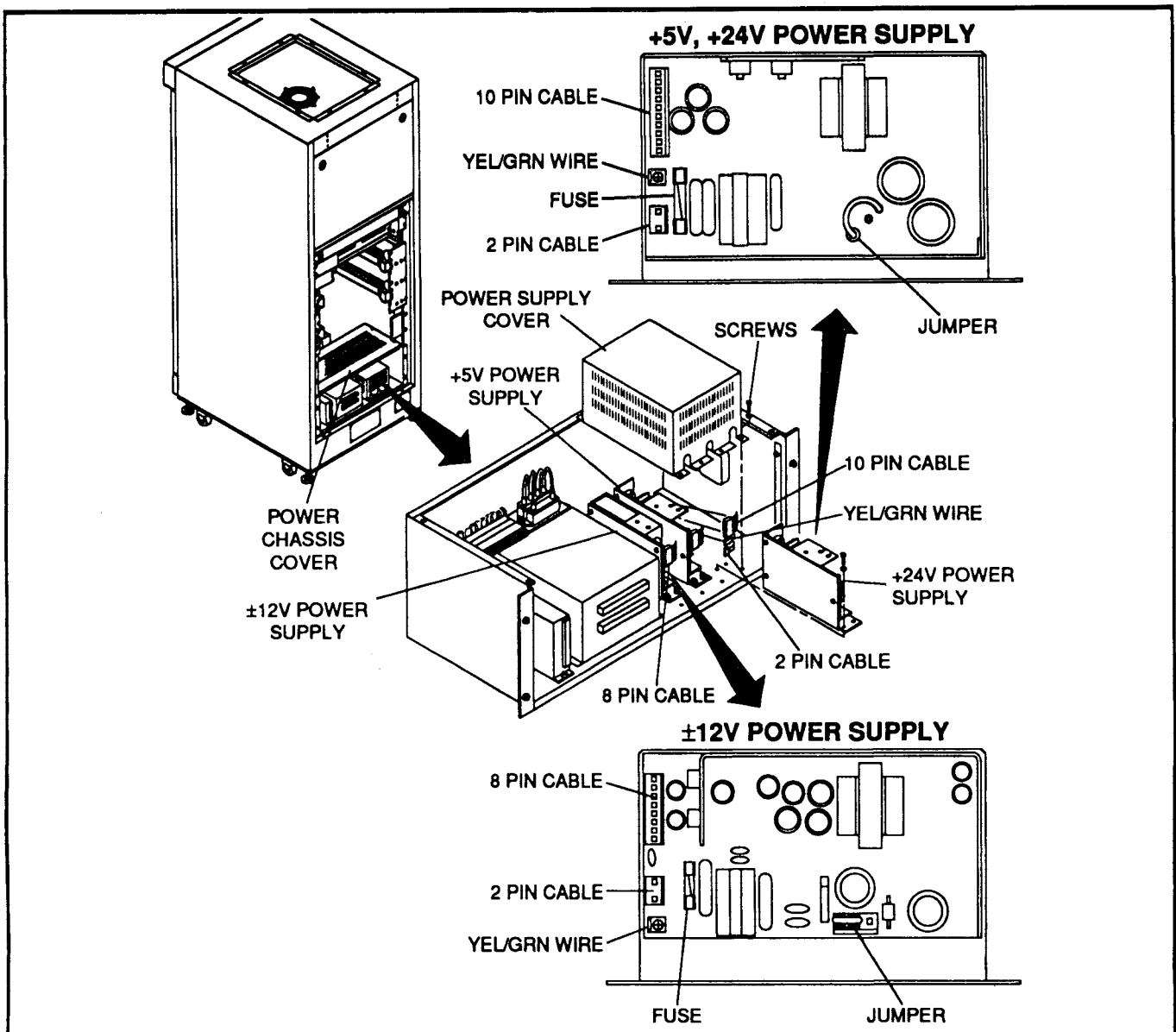

Figure 5-9. Power Supply Replacement

### 5.6.1.14. ROTARY STORAGE DRUM

The field replaceable items on the Rotary Storage Drum Assembly are as follows:

- Pulse Motor Driver (refer to paragraph 5.6.1.9)
- Drum Pulse Motor/Drive Belts
- Drum Gray Code Sensor CCA
- Drum Slit Sensor CCA
- Drum Face Tab

Procedures are provided for each assembly. Figure 5-10 illustrates Rotary Storage Drum removal and installation.

#### Removal

1. If installed, remove data cartridges from storage bins.
2. Remove the upper and lower rear panels (refer to paragraph 5.6.1.1).
3. Lower the Cartridge Loader (refer to paragraph 5.6.1.1).
4. Remove the four hex drive screws and lockwashers holding the drum to the front bracket.
5. Remove the bottom panel support (four screws, lockwashers, and flat washers).
6. Remove four screws, lockwashers, and flat washers holding the drum stops.
7. Disconnect the following cables:
  - 3 pin cable from J92
  - 10 pin cable from J31

#### WARNING

A minimum of 2 persons are required to perform the next step. If the Rotary Storage Drum is allowed to drop uncontrolled, serious bodily injury and/or equipment damage may result.

#### WARNUNG

Mindestens 2 Personen sind zur Ausführung des nächsten Schrittes erforderlich. Wenn die Rotationsspeichertrommel unkontrolliert fallen gelassen wird, kann das zu ernsthafter Körperverletzung bzw. Geräteschaden führen.

#### AVERTISSEMENT

Il faut au minimum 2 personnes pour effectuer l'opération suivante. Si on laisse tomber le tambour rotatif de stockage, on s'expose à des blessures et/ou à des dégâts matériels graves.

8. Slide the Rotary Storage Drum towards the rear and remove.

#### Installation

1. Install by reversing removal steps 8 through 1.

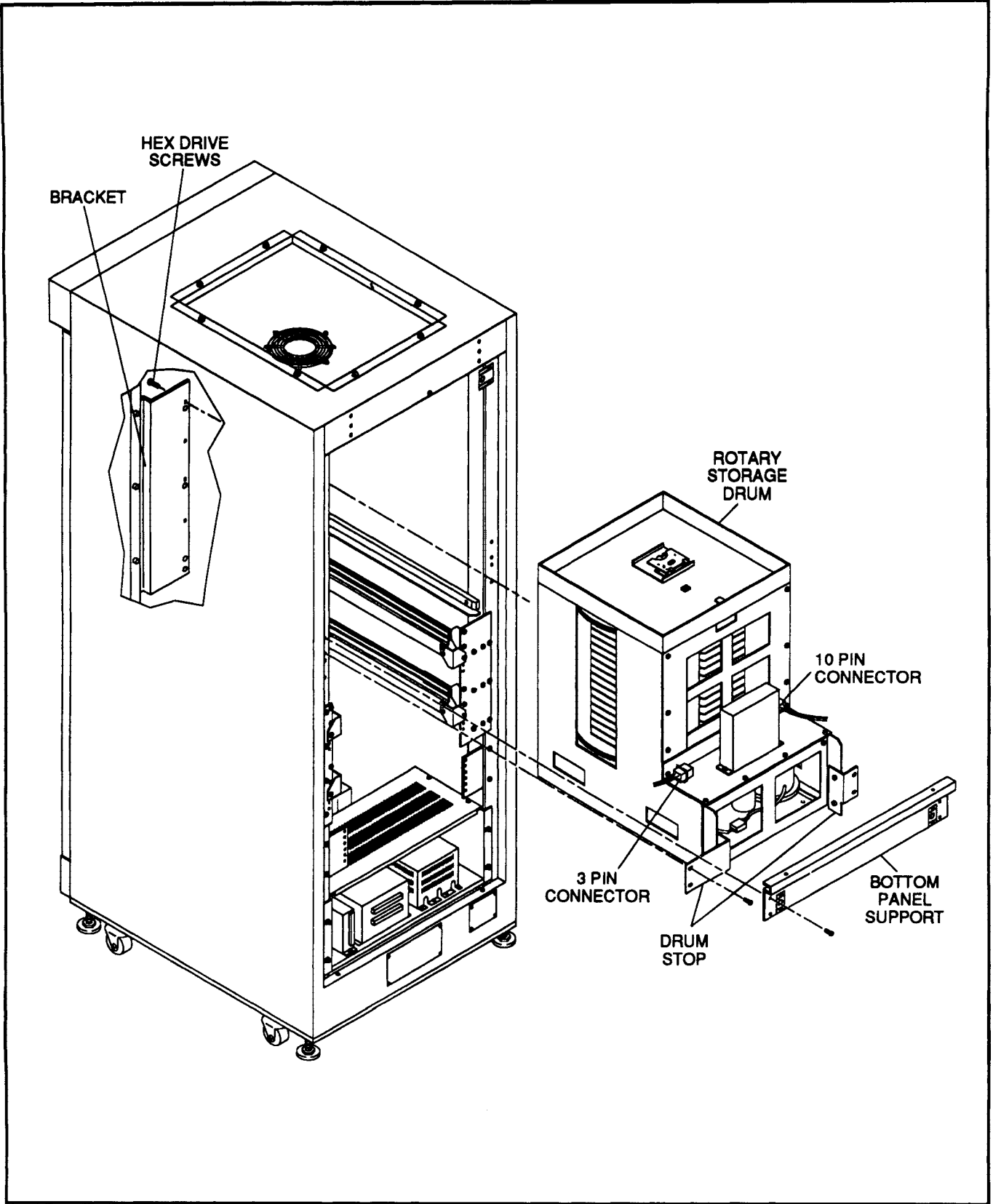

Figure 5-10. Rotary Storage Drum Assembly Replacement

### 5.6.1.14.1. Drum Pulse Motor/Drive Belts

Figure 5-11 illustrates Drum Pulse Motor/Drive Belt removal and installation.

**NOTE** If just removing drive belts, omit removal step 7 (and installation step 1).

#### Removal

1. Remove the Rotary Storage Drum (refer to paragraph 5.6.1.14).
2. Remove the driver bracket/Pulse Motor Driver combination (four screws and lockwashers)
3. Remove six screws, lock-washers, and flat washers holding the rear bracket.
4. Disconnect the 10-pin cable from J35.
5. Remove four screws, lockwashers, and flat washers holding the motor/bearing plate to the drum chassis.
6. Loosen the four screws holding bearing case A and B. Slide case forward and remove drive belts B and A.
7. Remove the Drum Pulse Motor (four screws and lockwashers).

#### Installation

1. Install Drum Pulse Motor (four screws, lockwashers, and flat washers).
2. Replace drive belts A and B. Adjust tension on drive belts A and B until it is within specified limits. Tension is changed by moving bearing case A.
3. Install motor/bearing plate in the drum chassis. Make sure drum and bearing case B gears are meshed, and that movement is free and smooth.
4. Finish installation by reversing steps 4 through 1.
5. If installing a replacement motor, perform Pulse Motor Adjustment (see paragraph 5.7).

### 5.6.1.14.2. Drum Gray Code Sensor CCA

Figure 5-11 illustrates Drum Gray Code Sensor CCA removal and installation.

#### Removal

1. Remove the Rotary Storage Drum (refer to paragraph 5.6.1.14).
2. Remove four screws, lockwashers, and flat washers holding the CCA.
3. Disconnect the following cables:
  - 3 pin cable at J33
  - 5 pin cable at J32
4. Rotate the rotary storage drum to face C and remove the Drum Gray Code Sensor CCA.

#### Installation

1. Install by reversing removal steps 4 through 1.

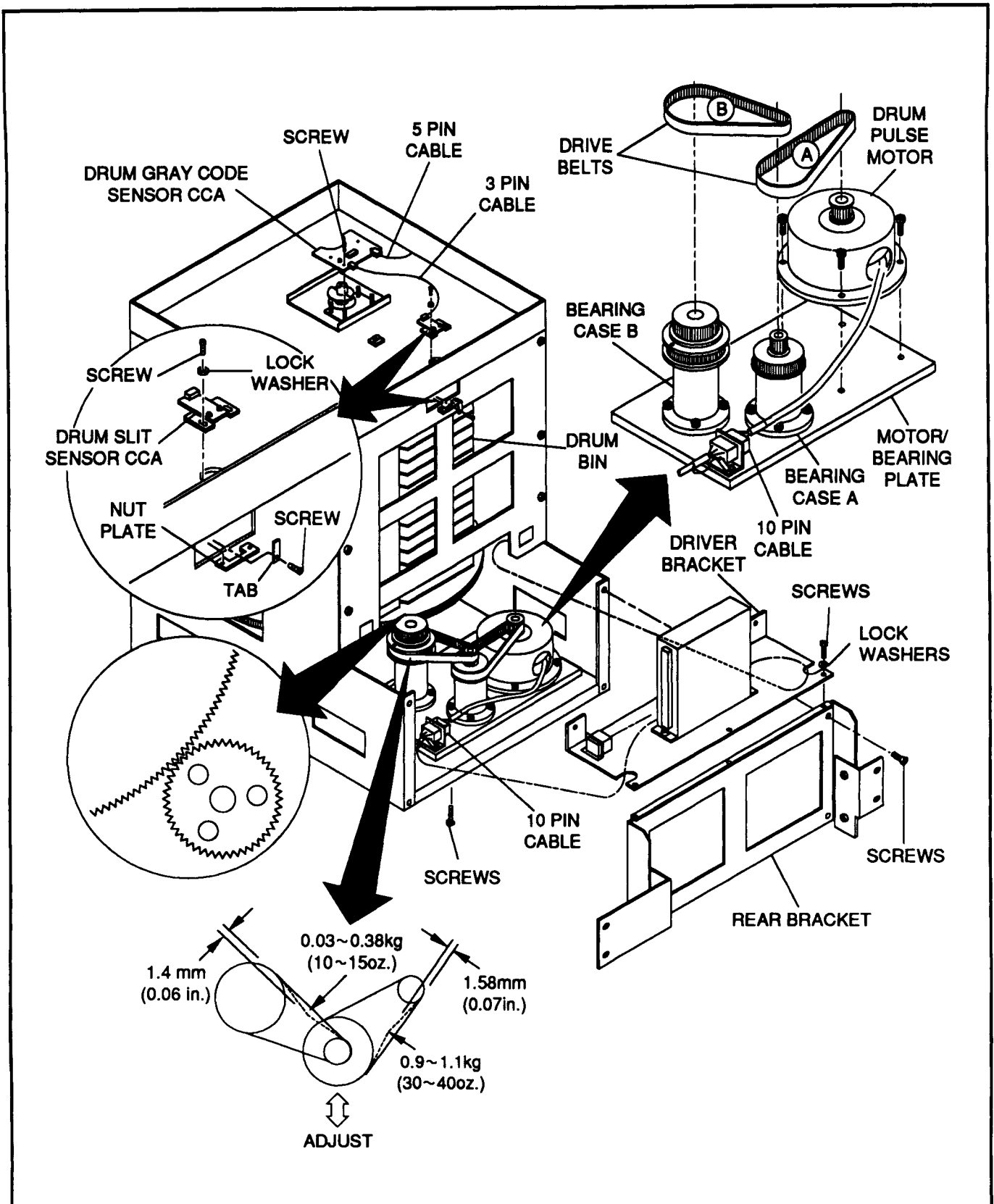

Figure 5-11. Drum Motor, Drive Belt, Sensor CCA, and Tab Replacement

### **5.6.1.14.3. Drum Slit Sensor CCA**

Figure 5-11 illustrates Drum Slit Sensor CCA removal and installation.

#### **Removal**

1. Remove the Rotary Storage Drum (refer to paragraph 5.6.1.14).
2. Rotate the Rotary Storage Drum until in between faces.
3. Remove two hex screws and flat washers holding the CCA/plate combination.
4. Disconnect the 3 pin cable at J34.
5. Remove the Drum Slit Sensor CCA.

#### **Installation**

1. Install by reversing removal steps 5 through 1.
2. Perform Drum Rotation Stop Adjustment (see paragraph 5.7).

### **5.6.1.14.4. Drum Face Tab**

Figure 5-11 illustrates Drum Face Tab removal and installation.

#### **Removal**

1. Remove the Rotary Storage Drum (refer to paragraph 5.6.1.14).
2. Remove screw and tab.

#### **Installation**

1. Install by reversing removal steps 2 through 1.
2. Perform Drum Rotation Stop Adjustment (see paragraph 5.7).

### 5.6.1.15. Handler Assembly

The field replaceable items on the Handler Assembly are as follows:

- Rubber Fingers
- Plate Springs
- Coil Springs
- Cartridge Sensor Switch
- Cartridge Sensor Switch Spring
- Z-Motor
- Drive Belt

Procedures are provided for each assembly. Figure 5-12 illustrates Handler Assembly removal and installation.

#### Removal

1. Open the front door (refer to paragraph 5.6.1.1).
2. Move the elevator to the upper most position and disconnect the 30-pin cable at J46.
3. Remove the Handler Assembly (four screws).

#### Installation

1. Place Handler Assembly on guide pins.
2. Install by reversing removal steps 3 through 1.
3. If installing a replacement assembly, perform Bar Code Adjustment and Z-Motor Adjustment (see paragraph 5.7).

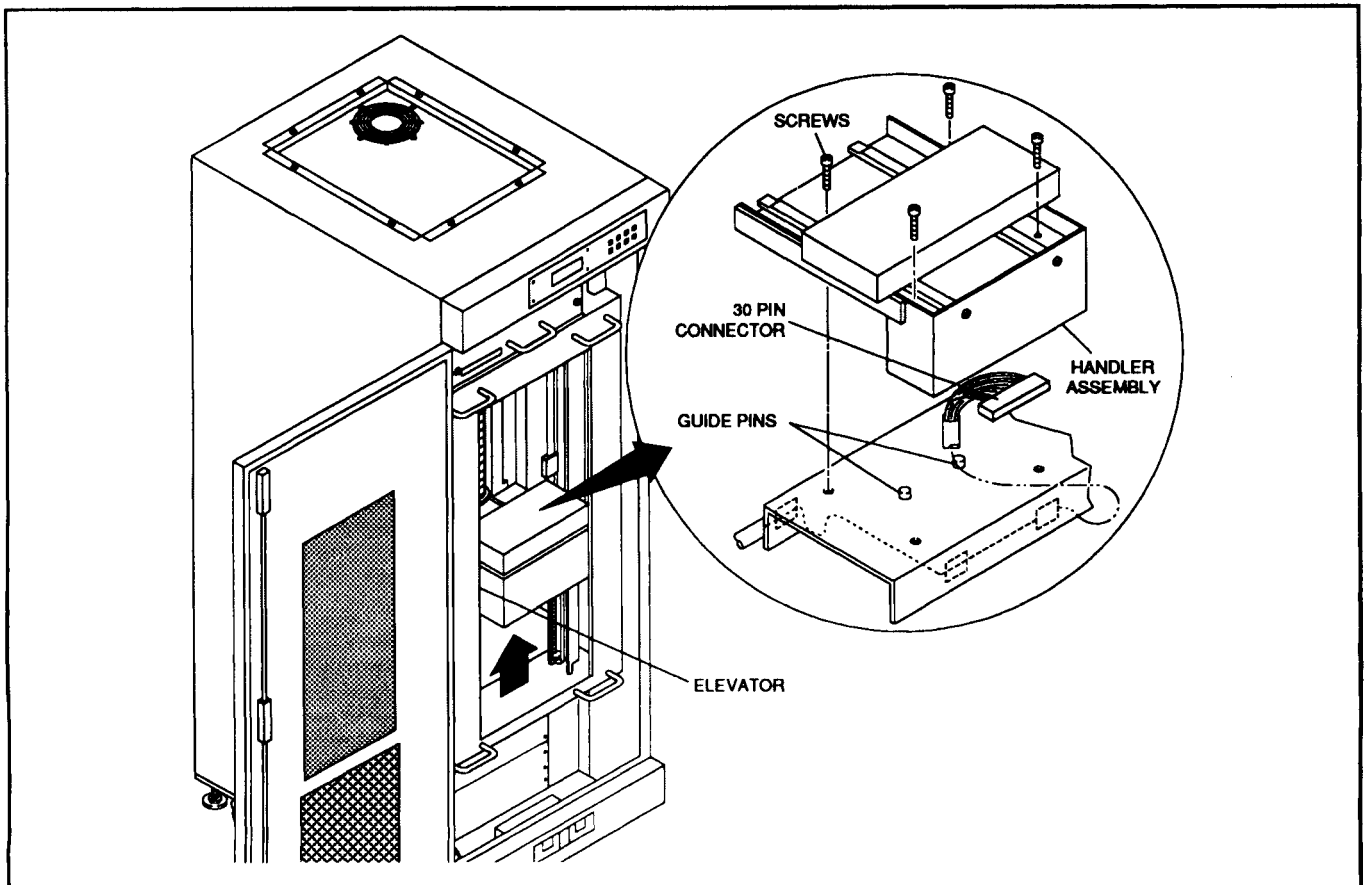

Figure 5-12. Handler Assembly Replacement

### 5.6.1.15.1. Rubber Fingers

Figure 5-13 illustrates Rubber Finger removal and installation.

#### Removal

1. Pull old rubber fingers from the arm.

#### Installation

1. Press replacement rubber fingers on arms with gripper towards the center.

### 5.6.1.15.2. Plate Springs

Figure 5-13 illustrates Plate Spring removal and installation.

#### Removal

1. Remove Plate Spring (one screw).

#### Installation

1. Install plate spring with rounded edge towards the center.

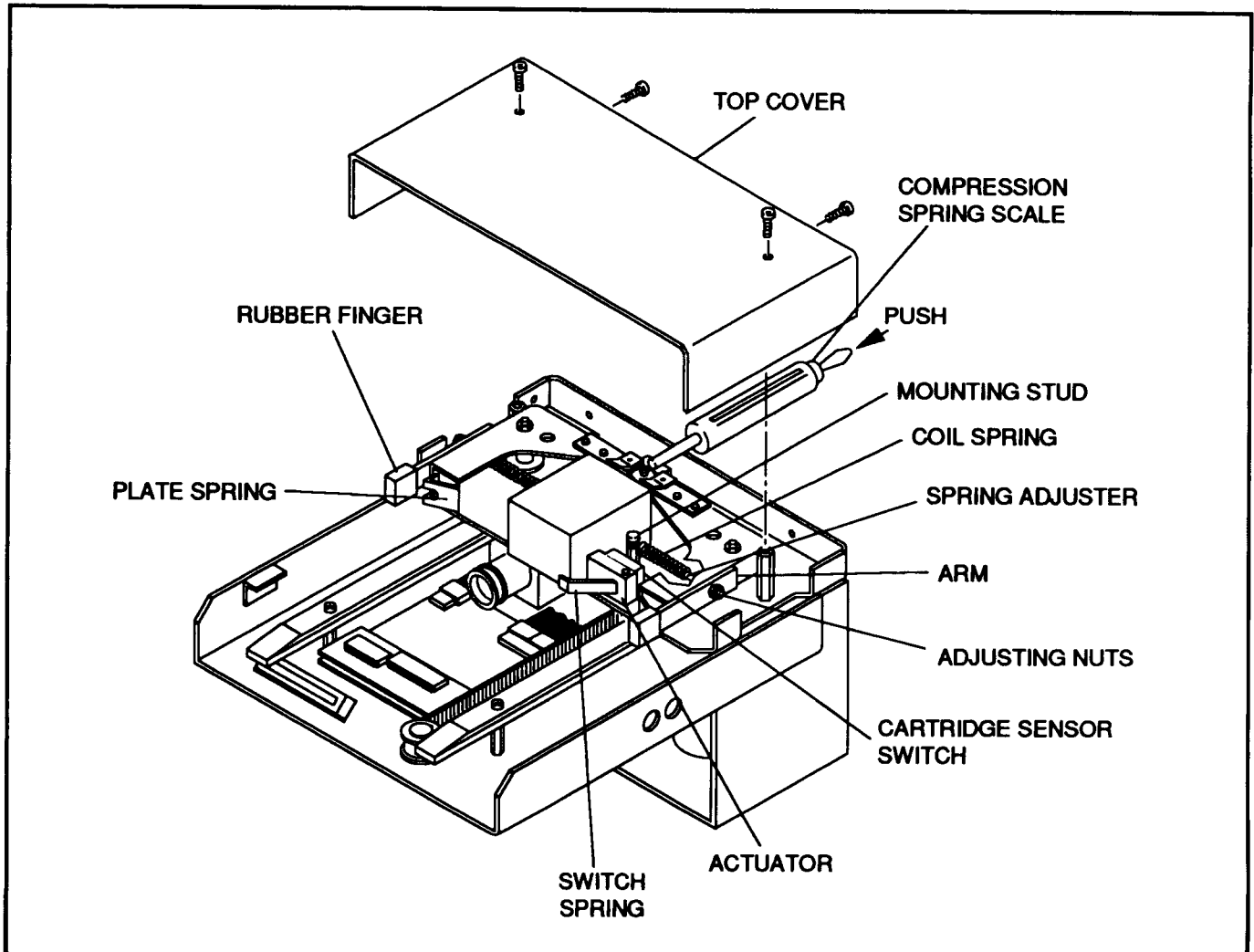

Figure 5-13. Handler Finger, Spring, and Switch Replacement

### **5.6.1.15.3. Coil Springs**

Figure 5-13 illustrates Coil Spring removal and installation.

#### **Removal**

1. Remove the cover (four screws).
2. Remove spring from mounting stud.
3. Remove spring adjuster (two nuts) and spring.
4. Repeat steps 1 through 3 for the other side.

#### **Installation**

1. Install by reversing removal steps 4 through 1. Install spring adjuster nuts (on both sides) so second nut is even with adjuster threads.
2. Using a 5 to 10 lb compression type spring scale, push on the screw head of the solenoid and adjust the spring adjuster nuts on both sides (equally) until it takes 4.4 lb (2 kg) of pressure to keep the solenoid pushed in.

### **5.6.1.15.4. Cartridge Sensor Switch**

Figure 5-13 illustrates Cartridge Sensor Switch removal and installation.

#### **Removal**

1. Remove the cover (four screws).
2. Remove two screws and lockwashers holding switch.
3. Tag and unsolder two wires.
4. Remove Cartridge Sensor Switch.

#### **Installation**

1. Install by reversing removal steps 4 through 1.

### **5.6.1.15.5. Cartridge Sensor Switch Spring**

Figure 5-13 illustrates Cartridge Sensor Switch Spring removal and installation.

#### **Removal**

1. Remove Cartridge Sensor Switch Spring (one screw).

#### **Installation**

1. Install Cartridge Sensor Switch Spring (one screw) as shown on figure.

### 5.6.1.15.6. Z-Motor

Figure 5-14 illustrates Z-Motor removal and installation.

#### Removal

1. Remove the Handler Assembly (refer to paragraph 5.6.1.15).
2. Move the carrier to the full forward position.
3. Remove the bottom cover (six screws).
4. Tag and unsolder two wires (RED and BLK).
5. Remove the Motor/motor bracket combination (two screws, lockwashers, and flat washers).

#### Installation

1. Start installation by reversing removal steps 5 and 4.
2. Loosen idler nut and move idler towards the rear. Place drive belt over the motor gear.
3. Adjust tension on drive belt by moving idler towards the front. Correct tension is when the teeth on the belt are engaged (without possibility of slippage) when the carriage is quickly moved forward and backward.
4. Complete installation by reversing removal steps 2 and 1.
5. If installing a replacement assembly, perform Z-Motor Adjustment (see para 5.7).

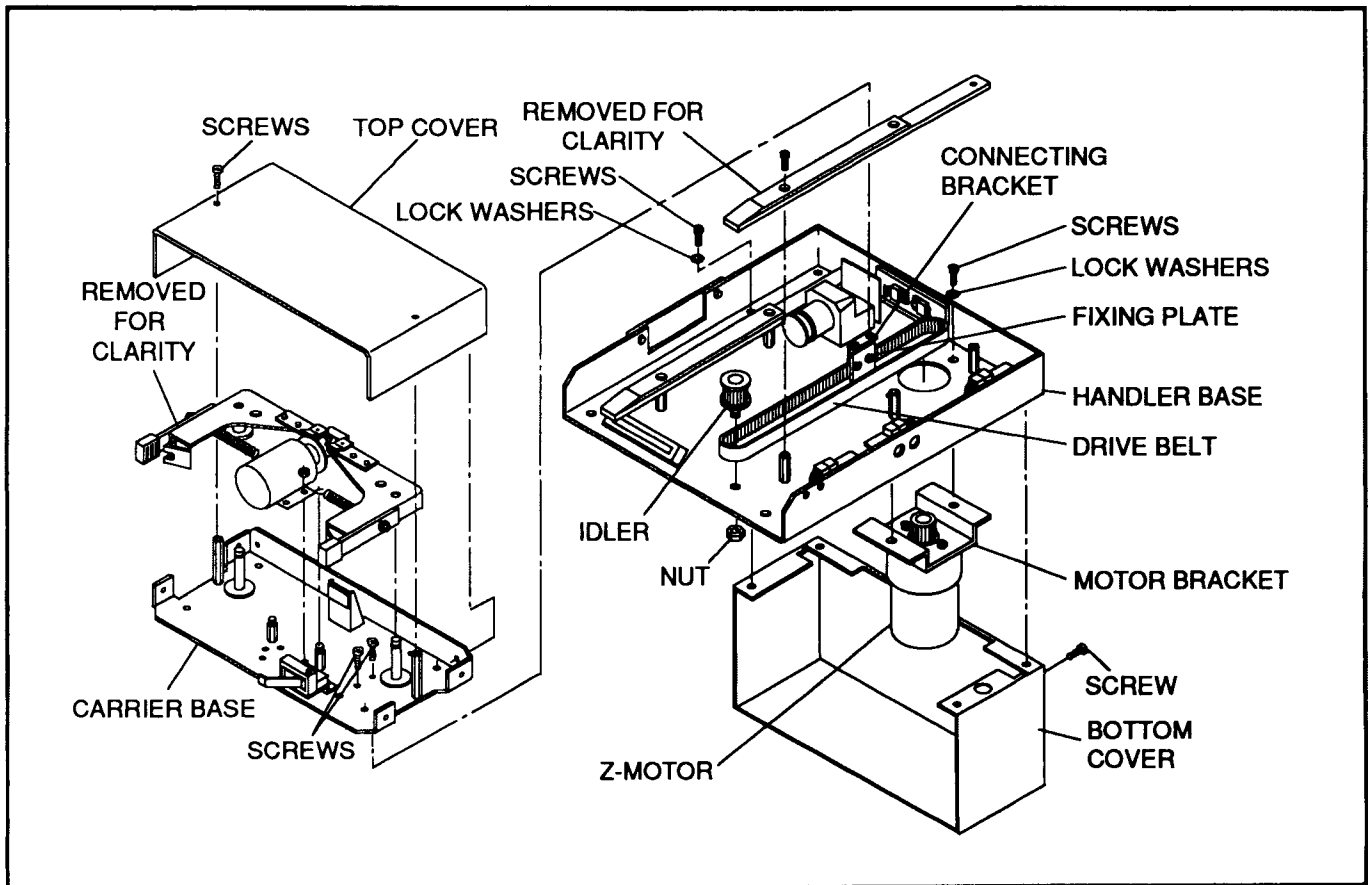

Figure 5-14. Handler Z-Motor and Drive Belt Replacement

### **5.6.1.15.7. Handler Drive Belt**

Figure 5-14 illustrates Drive Belt removal and installation.

1. Remove the top cover (four screws).
2. Move the carrier to the middle position.
3. Remove the two screws holding the drive belt connector bracket to the carrier base.
4. Loosen idler nut and move idler to reduce tension on drive belt.
5. Lift drive belt over the Z-Motor gear, and remove drive belt from front of handler.
6. Remove the fixing plate and connector bracket from drive belt (two screws, lockwashers, and flat washers).

#### **Installation**

1. Start installation by reversing removal steps 6 through 4.
2. Align carrier base holes with drive belt connector bracket and replace two screws, lockwashers, and flat washers.
3. Adjust tension on drive belt by moving idler towards the front. Correct tension is when the teeth on the belt are engaged (without possibility of slippage) when the carriage is quickly moved forward and backward.
4. Complete installation by reversing removal steps 2 and 1.

## 5.6.1.16. ELEVATOR ASSEMBLY

The field replaceable items on the Elevator Assembly are as follows:

- Elevator Sensor CCA
- 50-Pin Cable Assembly
- Elevator Motor Assembly
- Drive Belts
- A and B Guide Rollers

Procedures are provided for each assembly. Figure 5-15 illustrates Elevator (Cartridge Loader) removal and installation.

### Removal

1. Open the front door (refer to paragraph 5.6.1.1). Remove door (spring loaded hinge pins).
2. Lower the Cartridge Loader (refer to paragraph 5.6.1.1).
3. Disconnect the following cables:
  - 10 pin cable from J41/P41
  - 50 pin cable from J43/P43

#### WARNING

A minimum of 2 persons are required to perform the next step. If the Cartridge Loader Assembly is allowed to drop uncontrolled, serious bodily injury and/or equipment damage may result.

#### WARNUNG

Mindestens 2 Personen sind zur Ausführung des nächsten Schrittes erforderlich. Wenn die Patronenladeeinheit unkontrolliert fallen gelassen wird, kann das zu ernsthafter Körperverletzung bzw. Geräteschaden führen.

#### AVERTISSEMENT

Il faut au minimum 2 personnes pour effectuer l'opération suivante. Si on laisse tomber l'ensemble de chargeur à cartouche, on s'expose à des blessures et/ou à des dégâts matériels graves.

4. Raise the Cartridge Loader Assembly until horizontal, then lift and pull forward until guide pins clear pin guides.
5. Set Cartridge Loader Assembly on the floor.

### Installation

1. Install by reversing removal steps 5 through 1.

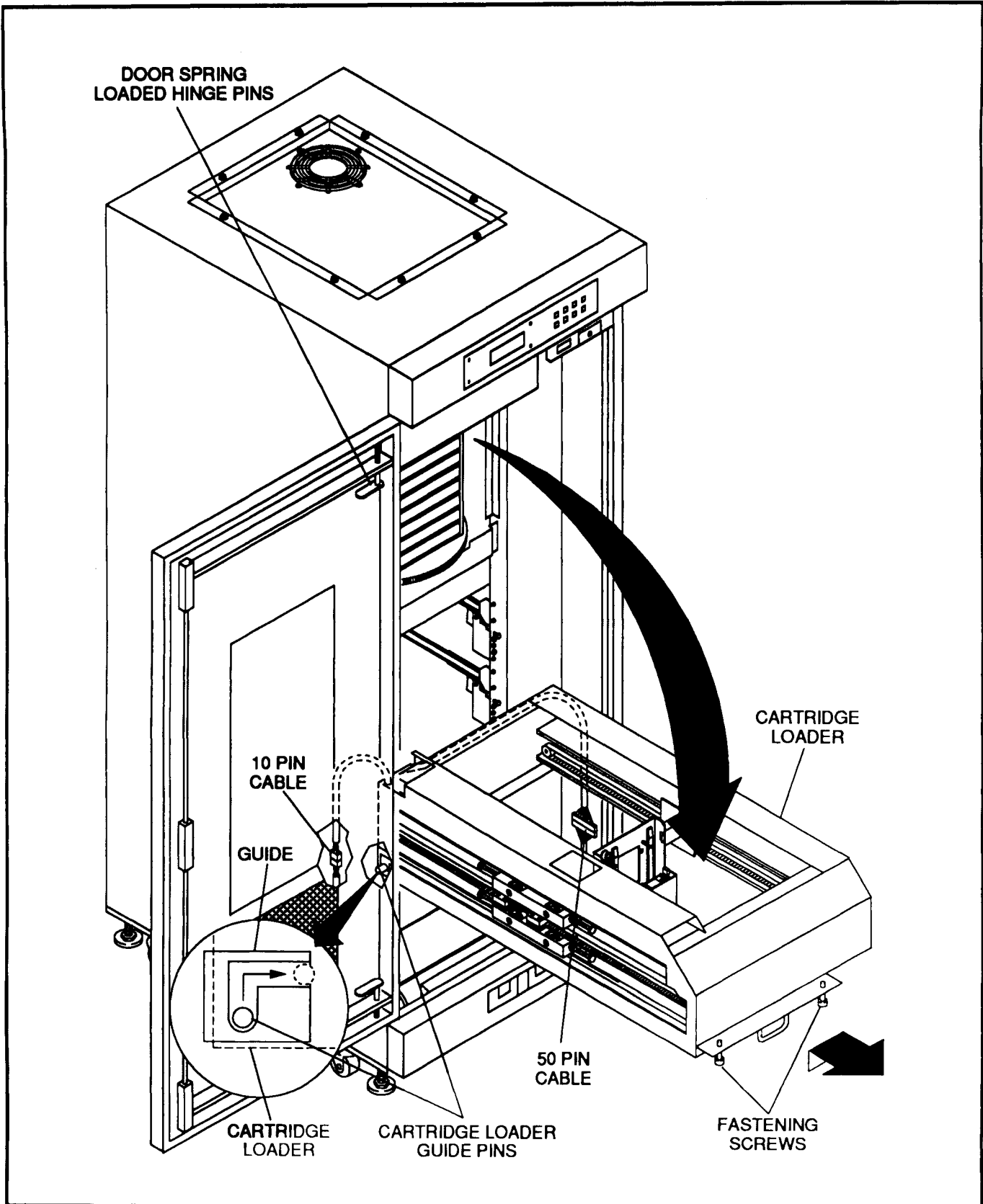

Figure 5-15. Elevator (Cartridge Loader) Assembly Replacement

### 5.6.1.16.1. Elevator Gray Code Sensor CCA

Figure 5-16 illustrates Elevator Gray Code Sensor CCA removal and installation.

#### Removal

1. Lower the Cartridge Loader (refer to paragraph 5.6.1.1).
2. Remove four screws, lockwashers, and flat washers holding the Sensor CCA/Cover combination.
3. Carefully lower and remove Sensor CCA/Cover combination from frame.
4. Remove two cable clamps (one screw and lockwasher each).
5. Remove four screws, lockwashers, and flat washers holding the cover.
6. Disconnect the following cables:
  - 30 pin cable from CN2
  - 50 pin cable from CN1
7. Remove the Sensor CCA.

#### Installation

1. Install by reversing removal steps 7 through 1.

**NOTE** Clearance from the sensor to the gray scale should be from 1.5 to 2.0 mm.

### 5.6.1.16.2. 50-Pin Cable Assembly

Figure 5-16 illustrates 50-Pin Cable Assembly removal and installation.

#### Removal

1. Remove the Elevator Gray Code Sensor CCA (paragraph 5.6.1.16.1).
2. Remove the upper and lower cable clamps (four screws, lockwashers, and flat washers).
3. Remove two cable clamps (one screw and lockwasher each).
4. Disconnect the 50 pin cable at J43/P43.
5. Carefully remove 50-Pin Cable from Cable Guide and the frame.

#### Installation

1. Install by reversing removal steps 5 through 1. Cable routing is as shown in the figure.

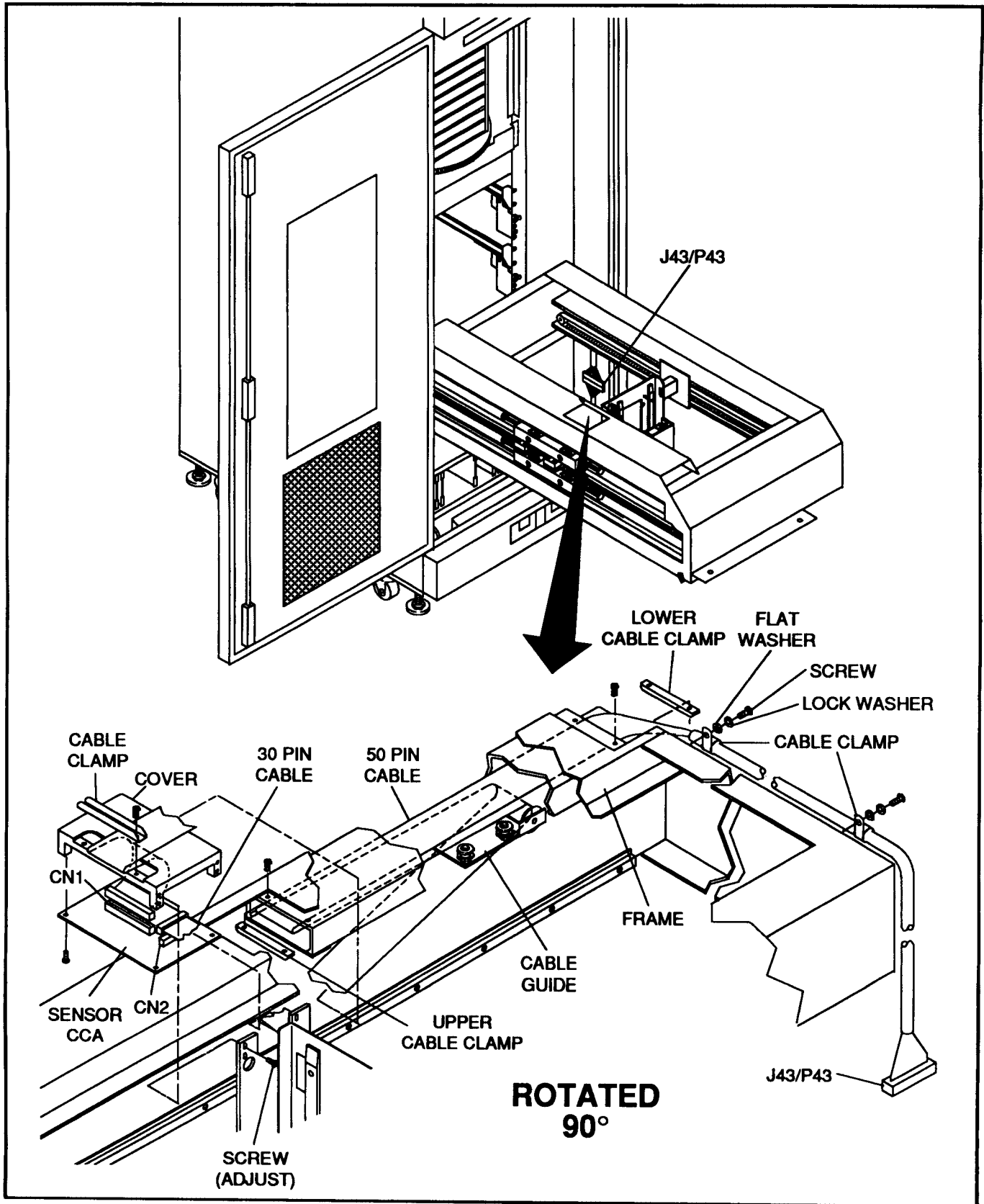

Figure 5-16. Elevator Sensor CCA and 50-Pin Cable Replacement

### 5.6.1.16.3. Elevator Motor Assembly

Figure 5-17 illustrates Elevator Motor removal and installation.

#### Removal

1. Remove the Elevator (Cartridge Loader) Assembly (paragraph 5.6.1.16).
2. Move the elevator to the lowest position and place the Cartridge loader on a flat surface (resting on it's handles) as shown.
3. Remove four hex drive screws holding rigid coupling.
4. Loosen eight hex drive screws holding both flexible couplings.
5. Remove the cable clamp (one screw, lockwasher, flat washer).
6. Disconnect the 10 pin cable (P42/J42).
7. Remove elevator motor/motor bracket combination (two hex drive screws).
8. Separate elevator motor and motor bracket (four hex drive screws).

#### Installation

1. Install by reversing removal steps 8 through 1.
2. Perform Elevator Horizontal and Height Adjustment (see paragraph 5.7).
3. Perform Pulse Motor Adjustment (see paragraph 5.7).

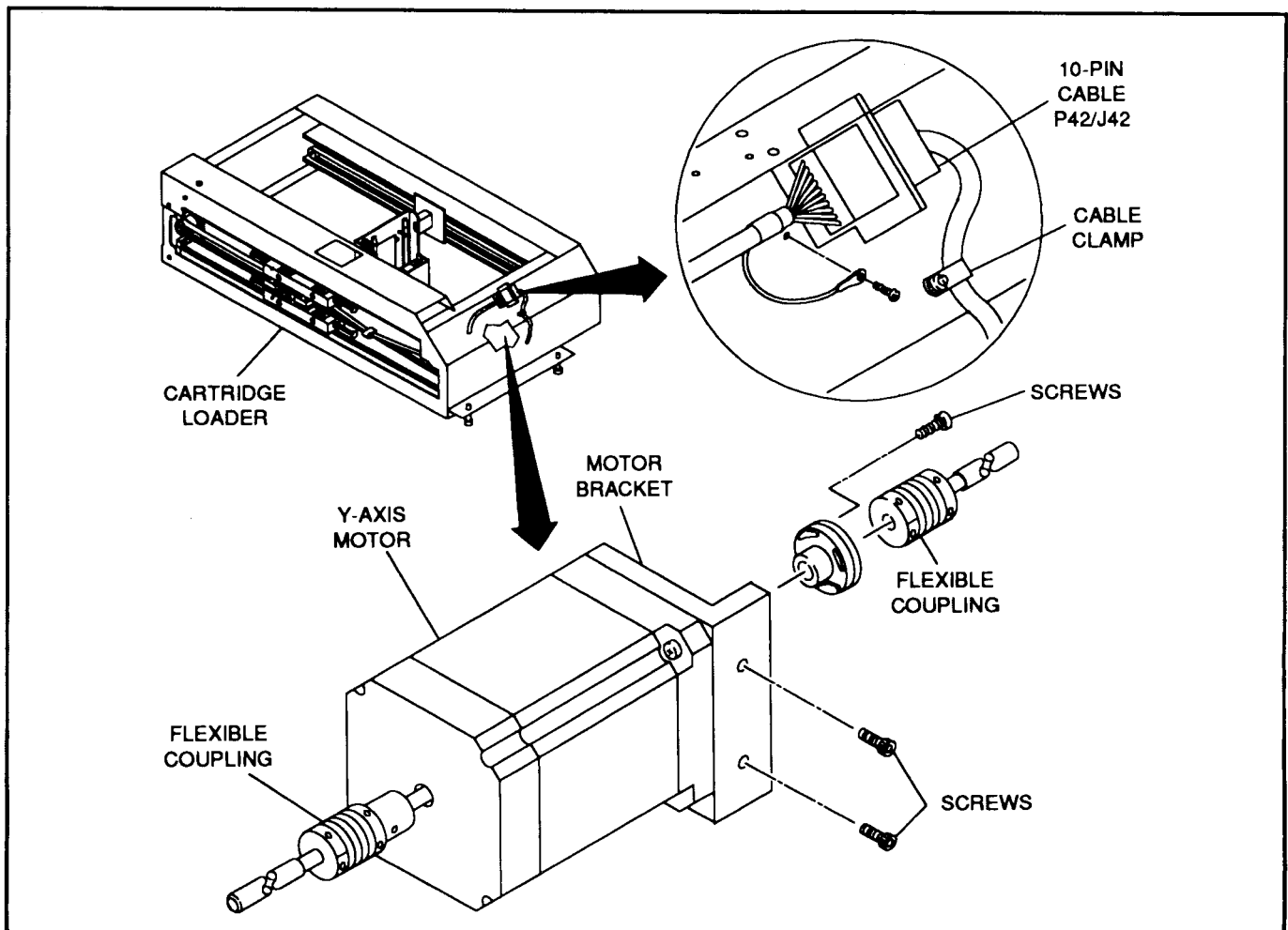

Figure 5-17. Elevator Motor Replacement

#### **5.6.1.16.4. Inner Drive Belt**

Figure 5-18 illustrates Inner Drive Belt removal and installation.

**NOTE** Procedure is identical for right and left sides.

##### **Removal**

1. Remove the Handler Assembly (paragraph 5.6.1.15).
2. Remove the Elevator (Cartridge Loader) Assembly (paragraph 5.6.1.16).
3. Move the elevator to the mid position and place the Cartridge loader on a flat surface (resting on it's handles) as shown.
4. Install two drive belt retainers (from shipping) on both outer drive belts (teeth interlocked).
5. Mark the position of the guide plate on the frame using tape.
6. Remove tension adjustment screw and nuts holding the upper support.
7. Remove four hex drive screw holding the plate to the lower support.
8. Remove the inner drive belt.
9. Remove both the upper and lower supports (eight screws).

##### **Installation**

1. Start installation by reversing removal steps 9 through 6.
2. Tighten four tension adjustment nuts just enough to apply tension to the drive belt. Guide plate must be at the same position as marked.
3. Remove drive belt retainers from the outer drive belt and move the elevator to the lowest position.
4. Adjust four tension adjustment nuts until drive belt tension (at the center of the belt) as shown.
5. Complete installation by reversing removal steps 2 and 1.
6. Perform Elevator Horizontal and Height Adjustment (see paragraph 5.7).

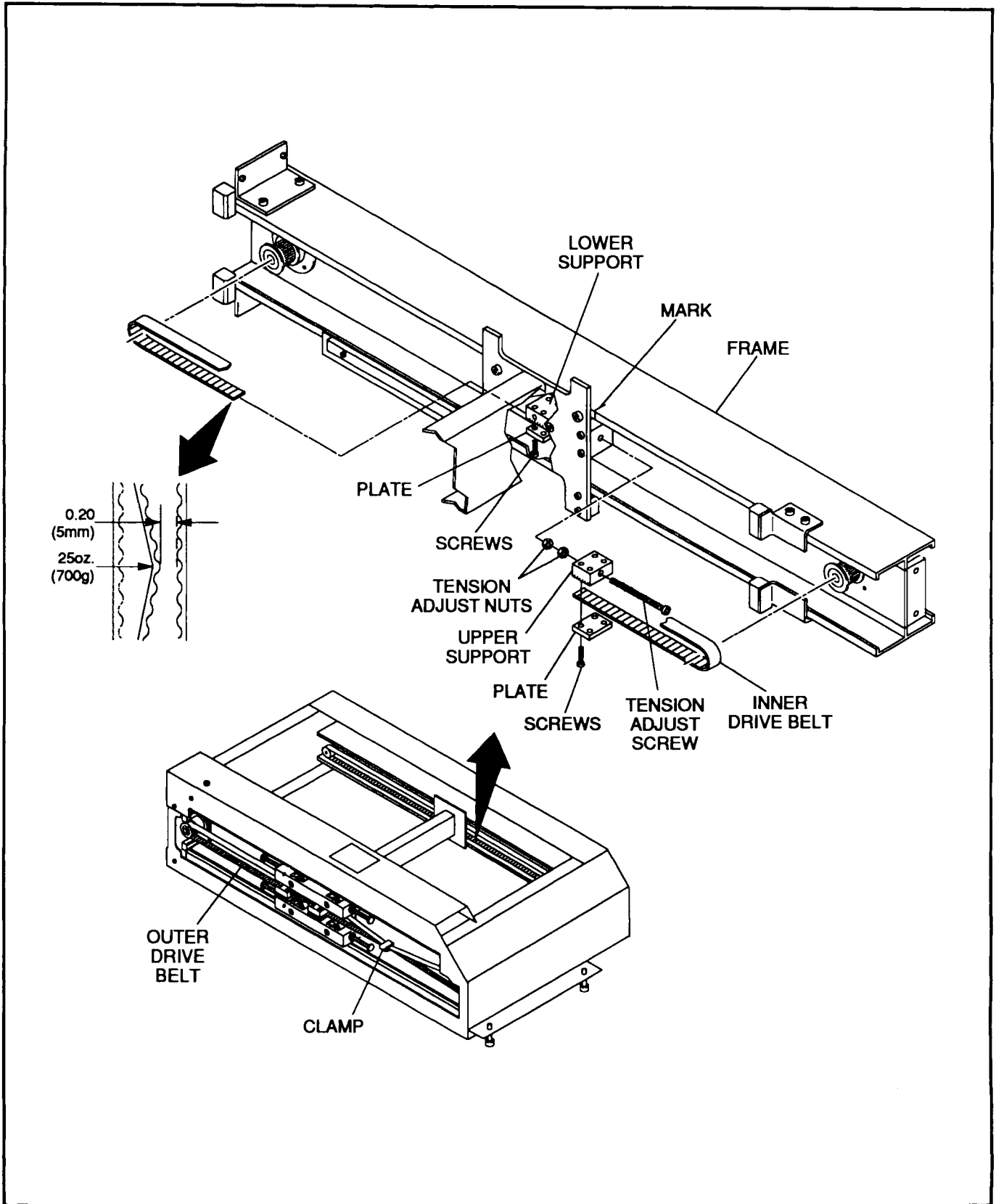

Figure 5-18. Inner Elevator Drive Belt Replacement

### 5.6.1.16.5. Outer Drive Belt

Figure 5-19 illustrates Outer Drive Belt removal and installation.

**NOTE** Procedure is identical for right and left sides.

#### **Removal**

1. Remove the Elevator (Cartridge Loader) Assembly (paragraph 5.6.1.16).
2. Move the elevator to the upper position and place the Cartridge loader on a flat surface (resting on it's handles) as shown.
3. Install two drive belt retainers (from shipping) on both inner drive belts (teeth interlocked).
4. Loosen two lock nuts, then the tension adjustment nut.
5. Remove two hex drive screws holding the lower support to the counter weight through the bottom hole.
6. Remove the outer drive belt.
7. Remove both the upper and lower supports (eight screws).

#### **Installation**

1. Start installation by reversing removal steps 7 and 5.
2. Tighten tension adjustment nut just enough to apply tension to the drive belt.
3. Remove drive belt retainers from the inner drive belt and move the elevator to the lowest position.
4. Adjust the tension adjustment nut until drive belt tension (at the center of the belt) as shown.
5. Complete installation by reversing removal step 1.
6. Perform Elevator Horizontal and Height Adjustment (see paragraph 5.7).

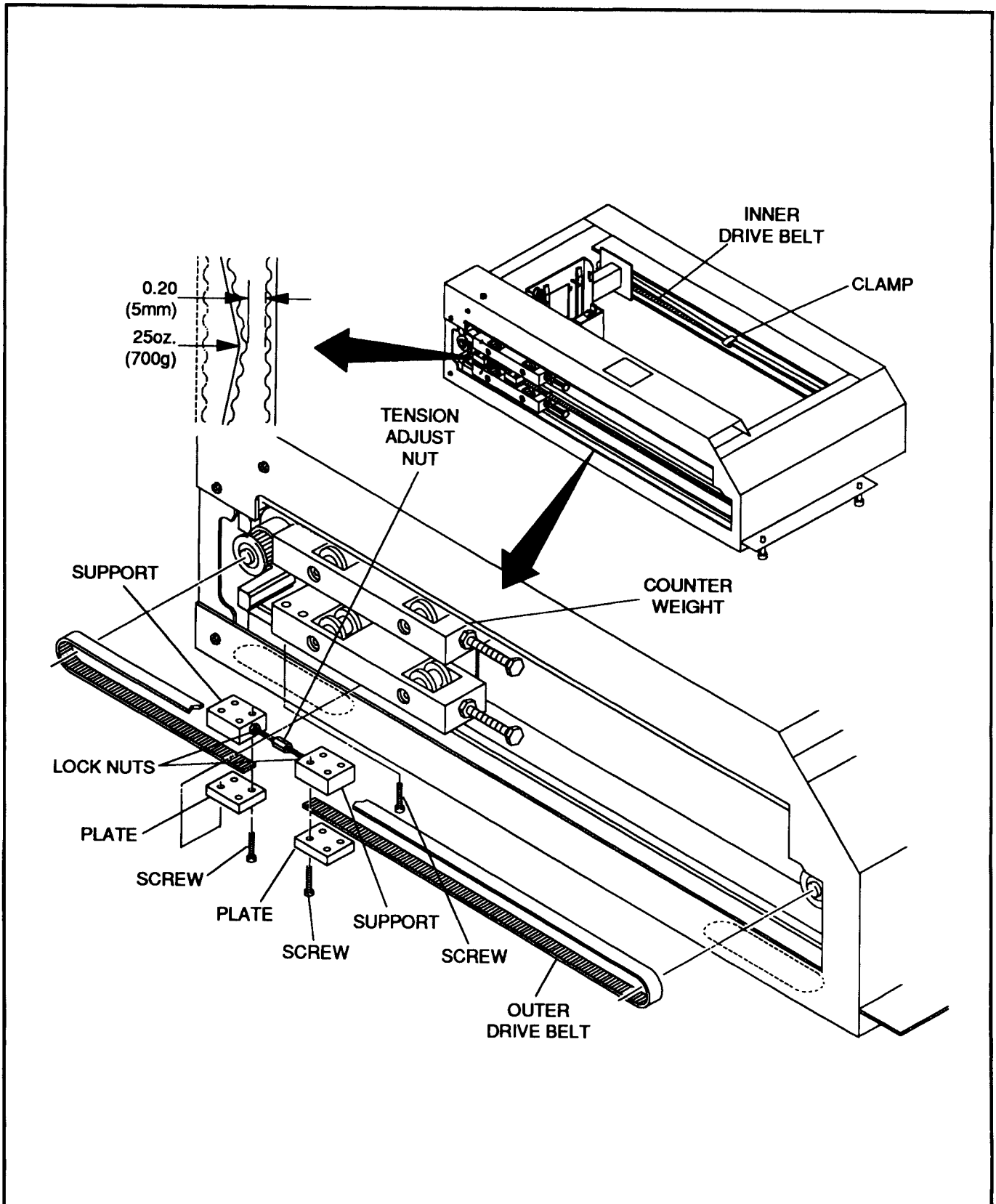

Figure 5-19. Outer Elevator Drive Belt Replacement

### **5.6.1.16.6. A and B Guide Rollers**

Figure 5-20 illustrates Guide Roller removal and installation.

#### **Removal**

1. Remove the Elevator (Cartridge Loader) Assembly (paragraph 5.6.1.16) if required to gain access to desired rollers.
2. Remove old A and B guide rollers (one hex drive screw).

#### **Installation**

1. Install new A and B guide rollers (one hex drive screw). A guide rollers can be tightened. B guide rollers should be snug.
2. B guide rollers are eccentric to allow adjustment of the rollers on the frame. Use the 10 mm wrench to rotate the B guide roller until:
  - there is no space between the A and B guide rollers and the frame.
  - roller movement is smooth and non-binding.
  - tighten screw to lock into place.
3. Install the Elevator (Cartridge Loader) Assembly (paragraph 5.6.1.16) if previously removed.

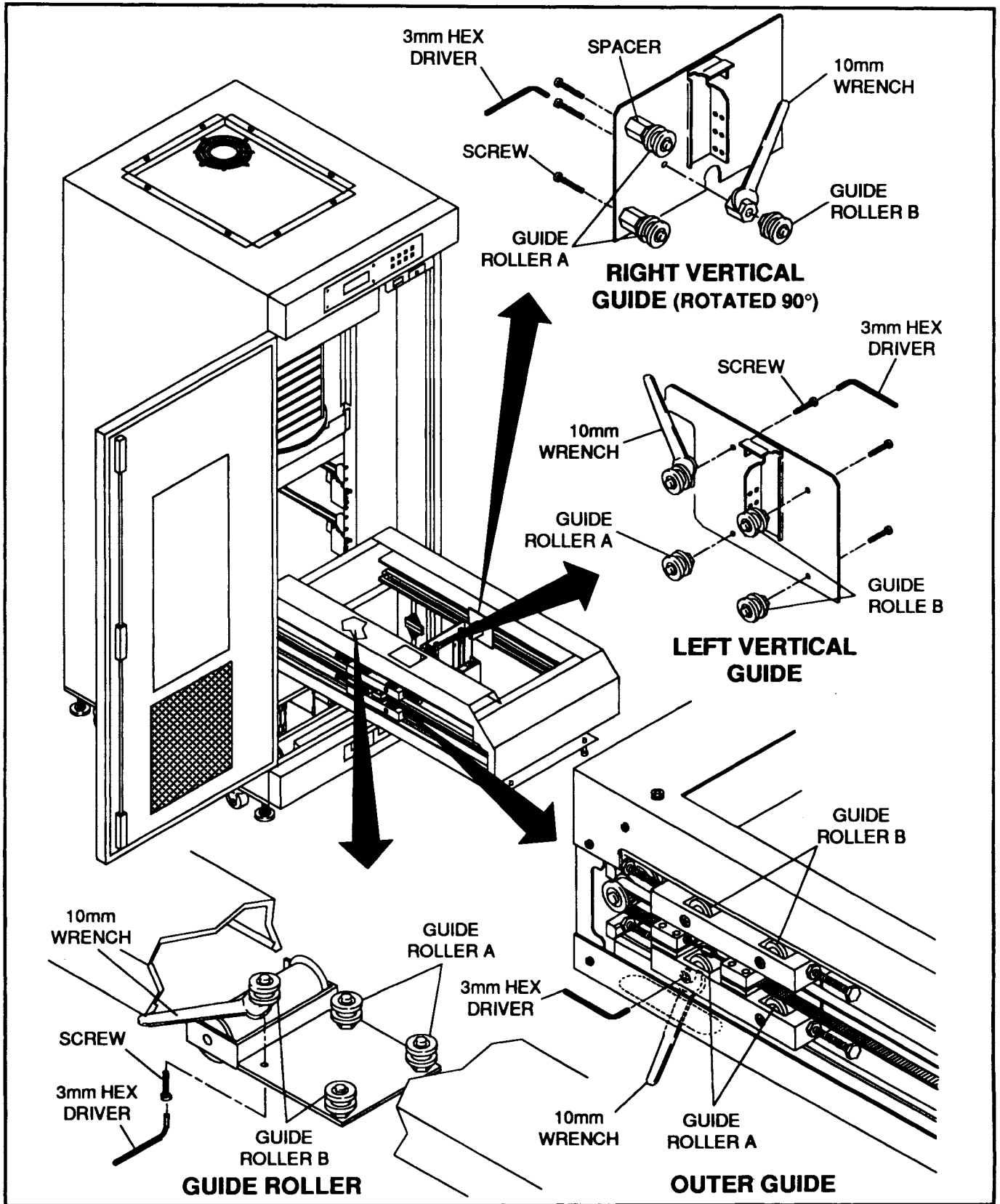

Figure 5-20. A and B Guide Roller Replacement

## **5.6.2 REPAIR**

The following information is provided to help the technician when repairing the RSS-48b.

- Limited repair explanation
- Where to find repair parts
- How to exchange defective modules
- The adjustments and/or calibration procedures needed after repair

**NOTE** A RSS-48b service training program is available upon request. This course is strongly recommended prior to servicing the RSS-48b. Contact your Distributor for more information.

### **5.6.2.1. LIMITED REPAIR**

Repair of the RSS-48b is basically limited to module exchange, with some individual high-wear parts included. This is due to a number of reasons, including:

- complexity of design
- cost of required test equipment
- interaction of various modules
- low failure rate
- low replacement cost
- repair time considerations

Because of these and other reasons, repair of the RSS-48b and its assemblies are limited to replacement of selected parts.

### **5.6.2.2. REPAIR PARTS**

All field replaceable parts are listed and illustrated in Section 6 of this manual.

### **5.6.2.3. REPAIR/EXCHANGE PROGRAM**

Certain modules in the RSS-48b are available on an exchange basis from the manufacturer. Defective modules are sent to the manufacturer, and in exchange, a factory repaired and tested module is returned. To see if a module is available on the repair/exchange program, contact your Distributor. A list of sales and service office locations are provided at the rear of this manual.

### **5.6.2.4. POST REPAIR ADJUSTMENTS**

RSS-48b adjustments that are required after a repaired or replaced assembly are provided and/or referenced in paragraph 5.7.

## 5.7. ADJUSTMENTS

RSS-48b adjustments and/or calibration(s) that are required after replacement or repair of assemblies, subassemblies, or modules are provided in the following paragraphs.

- Bar Code (para 5.7.3)
- Drum Rotation Stop (para 5.7.4)
- Elevator Horizontal and Height (para 5.7.5)
- Pulse Motor (para 5.7.1)
- Z-Motor (para 5.7.2)

Table 5-5 lists the specific adjustments required after installing a replacement assembly. If an assembly is not listed, no adjustment is required.

Table 5-5. Post-Repair Adjustments

Repaired/Replaced Assembly	Adjustment or Calibration Required
Drum Pulse Motor Drum SLIT Sensor CCA Drum Tab Elevator Motor Elevator Pulse Motor Handler Assy Handler Assy Inner Drive Belt Outer Drive Belt PM Controller CCA's Pulse Motor Drivers Z-Motor	Pulse Motor Drum Rotation Stop Drum Rotation Stop Elevator Horizontal and Height Pulse Motor Bar Code Z-Motor Elevator Horizontal and Height Elevator Horizontal and Height Pulse Motor Pulse Motor Z-Motor

**WARNING**

These procedures are performed with the covers removed and power applied to the RSS-48b. Voltages in excess of 100 volts are present inside the RSS-48b. Use only non-metallic tools when performing this procedure.

**WARNUNG**

Diese Vorgänge werden bei entfernten Abdeckungen und eingeschalteter RSS-48b durchgeführt. Spannungen von mehr als 100 Volt befinden sich im Inneren der RSS-48b. Nur nicht-metallische Werkzeuge benutzen, wenn dieser Vorgang durchgeführt wird.

**AVERTISSEMENT**

Ces opérations sont à effectuer avec les capots de protection ôtés pendant que le RSS-48b est sous tension. Le RSS-48b contient des composants sous tension de plus de 100 volts. N'utiliser que des outils non métalliques pour ces opérations.

**NOTE**

Figure 8-5 illustrates the locations for all test points and components referenced in this procedure (unless otherwise specified).

**NOTE**

There are a number of adjustable components on assemblies within the RSS-48b that can only be set at the factory. Only user adjustable components are described below. DO NOT adjust components unless instructed to do so.

### 5.7.1. PULSE MOTOR

The following procedure is used to set the pulse output on Pulse Motor Controller CCA #1 and/or #2. Figure 8-5 illustrates Pulse Motor adjustment location.

1. Open the front door (refer to paragraph 5.6.1.1).

2. Power-up the RSS-48b using the instructions provided in Section 3, paragraph 3.5.1.

**WARNING**

The next steps are performed with power applied to the RSS-48b and the front door open. Both electrical shock hazard and mechanical hazard from moving parts exist when operating the RSS-48b with the door open. Take necessary precautions to protect yourself from both hazards during the remainder of this procedure.

**WARNUNG**

Die nächsten Schritte werden bei eingeschalteter RSS-48b und geöffneter Fronttür durchgeführt. Sowohl die Gefahr eines elektrischen Schlags als auch die Gefahr durch sich bewegende Teile besteht, wenn die RSS-48b bei offener Tür betrieben wird. Die notwendigen Vorsichtsmaßnahmen zum Schutz gegen beide Gefahren sind für den Rest dieses Vorgangs zu treffen.

**AVERTISSEMENT**

Les opérations suivantes doivent être effectuées avec le RSS-48b sous tension et le panneau avant ouvert. Il existe dans ces conditions des dangers d'électrocution et des risques de blessures provenant de pièces mécaniques en mouvement. Prendre les précautions nécessaires pour se protéger de ces deux dangers pendant le reste de cette opération.

3. Locate the interlock switch on the upper right side of the RSS-48b and pull the plunger to the full out position (interlock defeated).
4. Connect an Oscilloscope to Pulse Motor Controller CCA at TP3 (Pulse A) and GND (see Figure 8-5).
  - Drum pulse – Pulse Motor Controller CCA #1.
  - Elevator pulse– Pulse Motor Controller CCA #2.

**NOTE** Adjustment must be performed while the corresponding motor is running at full speed.

- Drum pulse – Drum face from A to C or B to D.
  - Elevator pulse– Elevator from tape drive 02 to bin 01.
5. While motor's are running, adjust VR1 on Pulse Motor Controller CCA until the minimum pulse width is as specified.
    - Drum pulse – Pulse Motor Controller CCA #1 for a minimum pulse width of 40 $\mu$ sec.
    - Elevator pulse – Pulse Motor Controller CCA #2 for a minimum pulse width of 94 $\mu$ sec.
  6. Shut down the RSS-48b using the instructions provided in Section 3, para 3.5.3.
  7. Disconnect test equipment and close front door.

## 5.7.2. Z-MOTOR

The following procedure is used to set the DC voltage to the Z-Motor. Figure 8-5 illustrates Z-Motor adjustment location.

1. Open the front door (refer to paragraph 5.6.1.1).
2. Remove the handler's bottom cover (six screws).

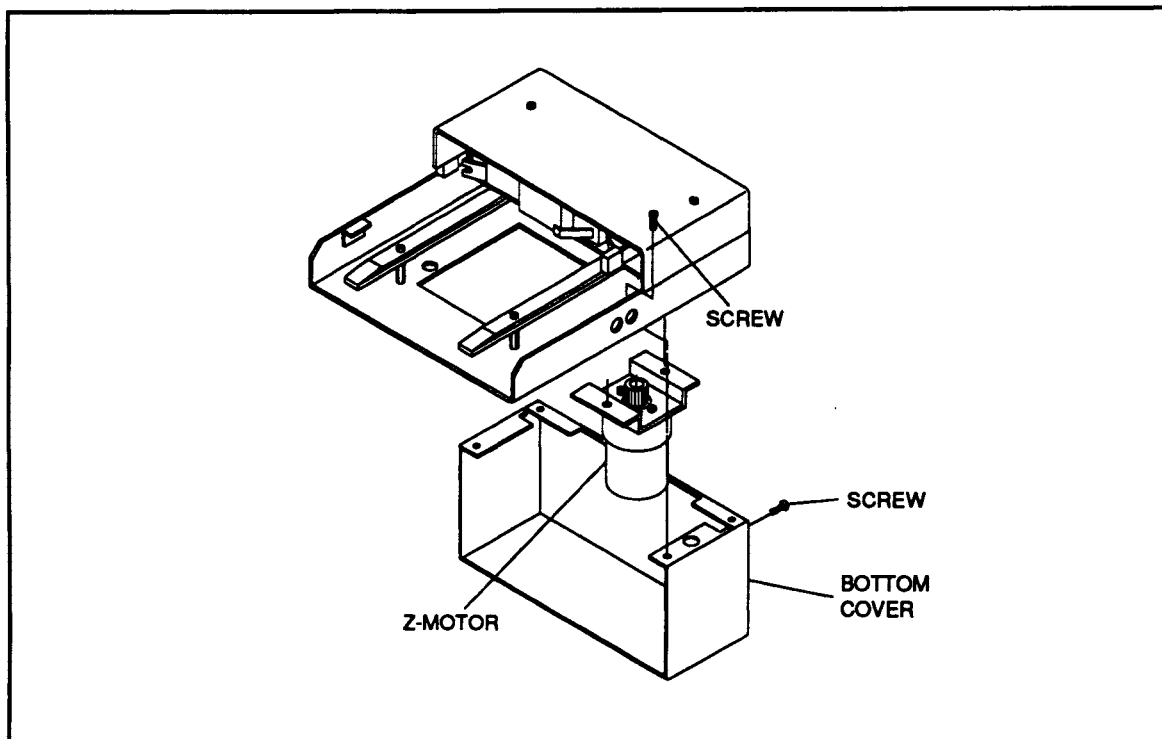

Figure 5-21. Handler Cover

3. Power-up the RSS-48b using the instructions provided in Section 3, paragraph 3.5.1.

**WARNING**

The next steps are performed with power applied to the RSS-48b and the front door open. Both electrical shock hazard and mechanical hazard from moving parts exist when operating the RSS-48b with the door open. Take necessary precautions to protect yourself from both hazards during the remainder of this procedure.

**WARNUNG**

Die nächsten Schritte werden bei eingeschalteter RSS-48b und geöffneter Fronttür durchgeführt. Sowohl die Gefahr eines elektrischen Schlags als auch die Gefahr durch sich bewegende Teile besteht, wenn die RSS-48b bei offener Tür betrieben wird. Die notwendigen Vorsichtsmaßnahmen zum Schutz gegen beide Gefahren sind für den Rest dieses Vorgangs zu treffen.

**AVERTISSEMENT**

Les opérations suivantes doivent être effectuées avec le RSS-48b sous tension et le panneau avant ouvert. Il existe dans ces conditions des dangers d'électrocution et des risques de blessures provenant de pièces mécaniques en mouvement. Prendre les précautions nécessaires pour se protéger de ces deux dangers pendant le reste de cette opération.

4. Locate the interlock switch on the upper right side of the RSS-48b and pull the plunger to the full out position (interlock defeated).
5. Connect a Digital Multimeter to the Z-Motor terminals (see Figure 8-5).

**NOTE** Adjustment must be performed with the handler fingers in the open position and the handler in the eject state.

6. Press and hold the front panel EJECT button, and adjust VR1 on Z-Motor Driver CCA until the Digital Multimeter reads +12 Vdc  $\pm 0.5$  V.
7. Shut down power to the RSS-48b using the instructions provided in Section 3, paragraph 3.5.3.
8. Disconnect test equipment, replace bottom cover, and close front door.

### 5.7.3. BAR CODE

The following procedure is used to adjust the bar code camera, reader, and decoder circuitry. Figure 8-5 illustrates Bar Code adjustment locations.

1. Open the front door (refer to paragraph 5.6.1.1).
2. Insert a data cartridge with bar code label into rotary storage drum bin #12 (current face).
3. Power-up the RSS-48b using the instructions provided in Section 3, paragraph 3.5.1.

#### **WARNING**

The next steps are performed with power applied to the RSS-48b and the front door open. Both electrical shock hazard and mechanical hazard from moving parts exist when operating the RSS-48b with the door open. Take necessary precautions to protect yourself from both hazards during the remainder of this procedure.

#### **WARNUNG**

Die nächsten Schritte werden bei eingeschalteter RSS-48b und geöffneter Fronttür durchgeführt. Sowohl die Gefahr eines elektrischen Schlags als auch die Gefahr durch sich bewegende Teile besteht, wenn die RSS-48b bei offener Tür betrieben wird. Die notwendigen Vorsichtsmaßnahmen zum Schutz gegen beide Gefahren sind für den Rest dieses Vorgangs zu treffen.

#### **AVERTISSEMENT**

Les opérations suivantes doivent être effectuées avec le RSS-48b sous tension et le panneau avant ouvert. Il existe dans ces conditions des dangers d'électrocution et des risques de blessures provenant de pièces mécaniques en mouvement. Prendre les précautions nécessaires pour se protéger de ces deux dangers pendant le reste de cette opération.

4. Locate the interlock switch on the upper right side of the RSS-48b and pull the plunger to the full out position (interlock defeated).
5. Use the UP/DOWN buttons to position the handler at the data cartridge in the rotary storage drum #12.
6. Connect the trigger input of an Oscilloscope to the handler Bar Code Reader CCA at TP2 (see Figure 8-5).

### 5.7.3.1. CCD CAMERA LENS

7. Connect the Oscilloscope channel A input to the handler Bar Code Reader CCA at TP3 (see Figure 8-5). Set the Oscilloscope controls as follows:
  - Time/Div to 10 msec
  - V/Div to 5V
8. Adjust the lens on the CCD Camera until the waveform is as shown in Figure 5-22.

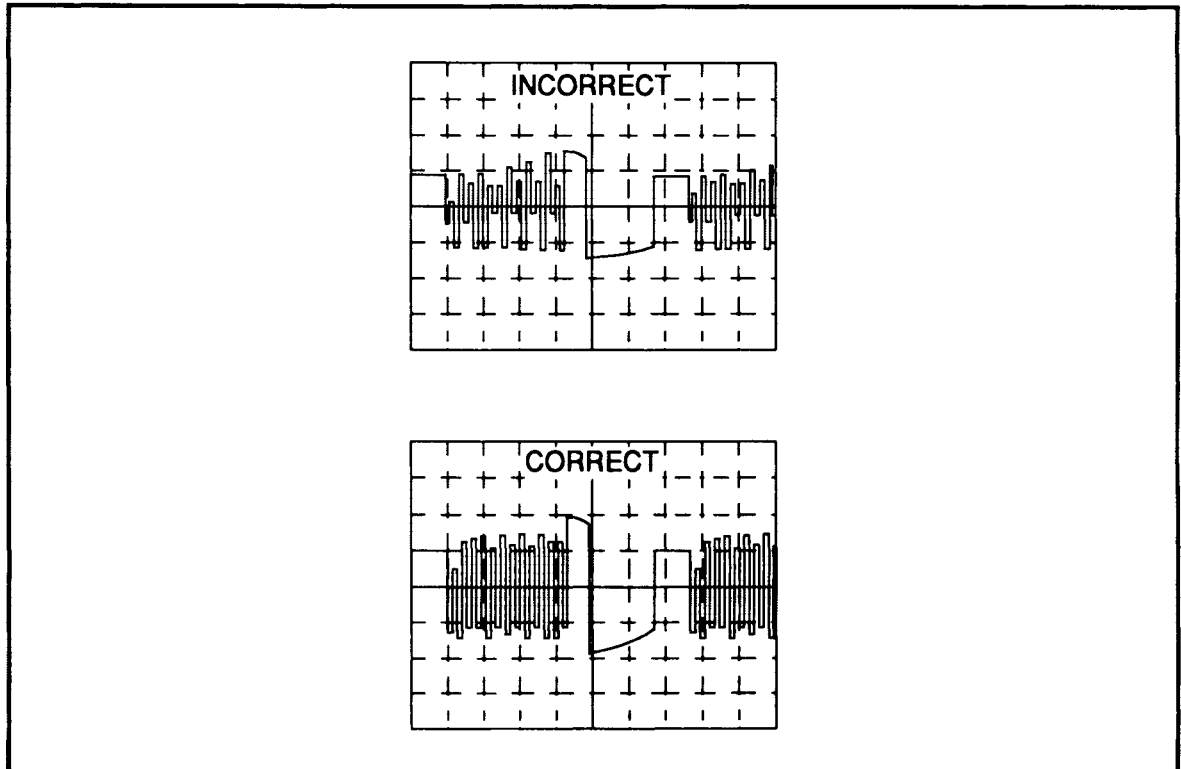

Figure 5-22. Lens Focusing

### 5.7.3.2. BAR CODE DC LEVEL

9. Use the UP/DOWN buttons to move the handler to a rotary storage drum bin without a data cartridge installed.
10. Set the Oscilloscope controls as follows:
  - Time/Div to 10 msec
  - V/Div to 1 V
11. Adjust VR3 until the DC level is  $-1$  V as shown in Figure 5-23.

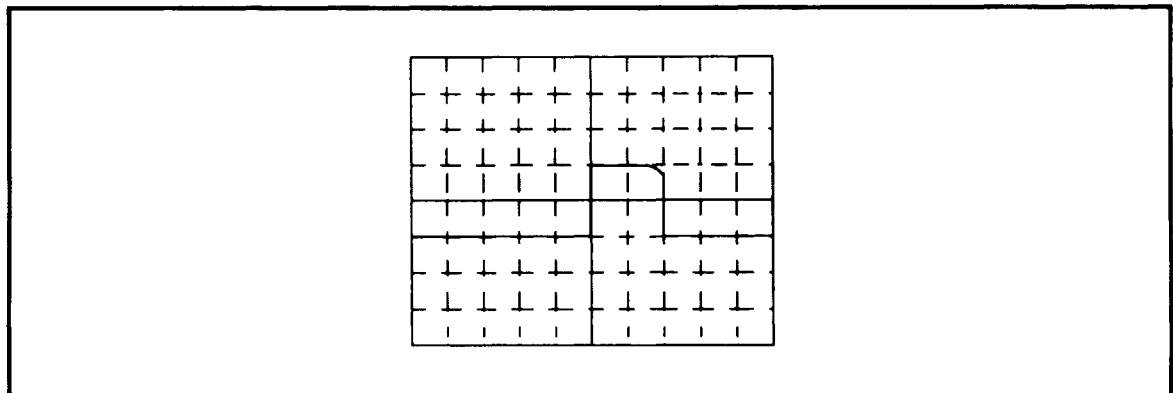

Figure 5-23. DC Level

12. Verify that LED D5 is OFF.
  - If ON, readjust VR3 (more negative) until the D5 just goes out (do not adjust below  $-2.0$  Vdc).
13. Use the UP/DOWN buttons to move the handler to a rotary storage drum bin with a data cartridge installed.
14. Verify that LED D5 is ON.
  - If OFF, readjust VR3 (more positive) until the D5 just goes on (do not adjust above  $-0.5$  Vdc).

### 5.7.3.3. BAR CODE GAIN

15. Use the UP/DOWN buttons to move the handler to a rotary storage drum bin with a data cartridge installed (with bar code label).
16. Set the Oscilloscope controls as follows:
  - Time/Div to 10 msec
  - V/Div to 5V

17. Adjust VR1 until the waveform amplitude is 12 Vp-p as shown in Figure 5-24.

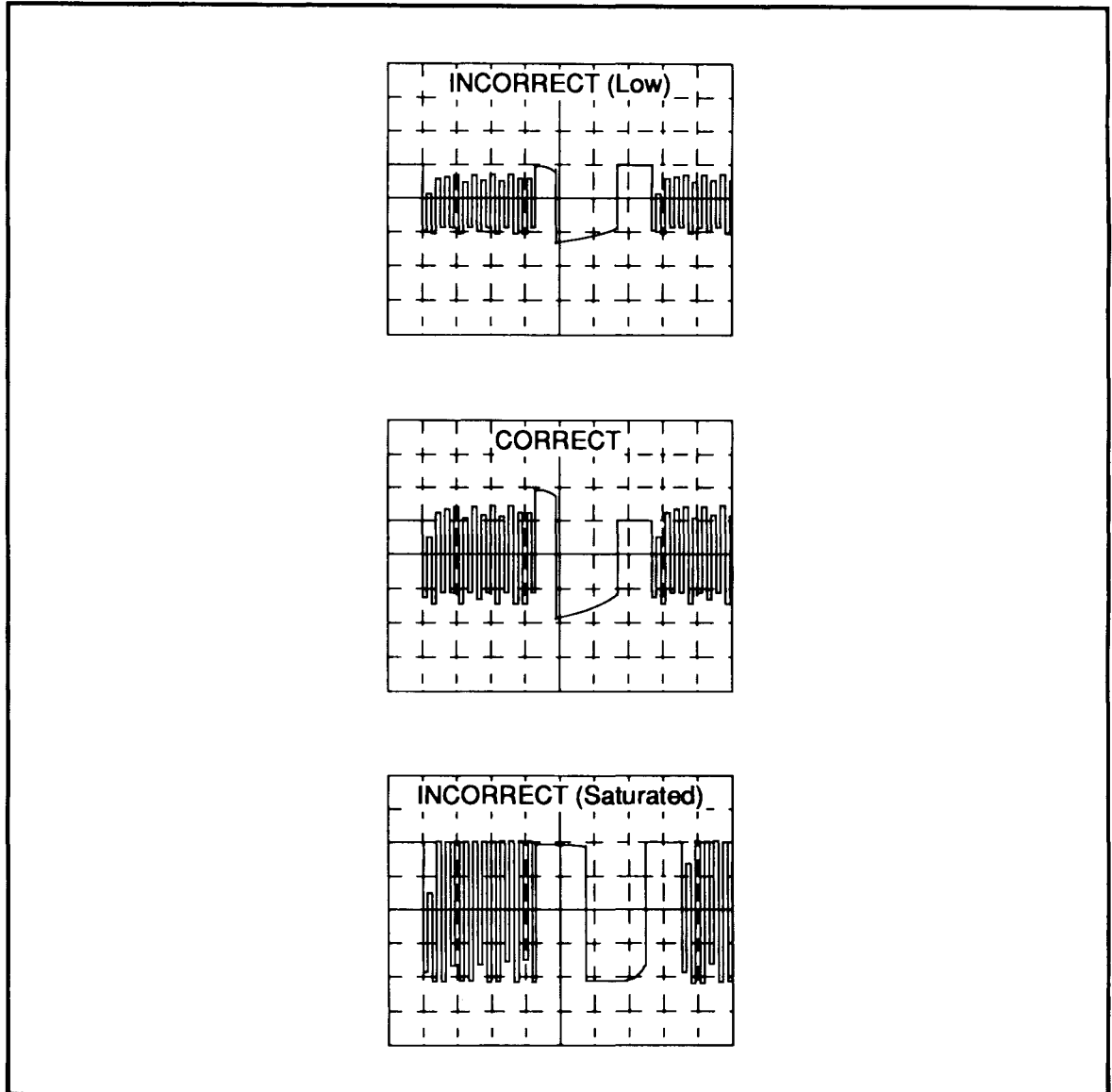

Figure 5-24. Gain

#### 5.7.3.4. SLICE LEVEL

18. Leave the Oscilloscope channel A input at TP3 and connect channel B to TP4. Set the Oscilloscope controls as follows:
- Time/Div to 10 msec
  - V/Div to 5V (A and B)
  - Mode to chop

19. Adjust VR2 until the signal at TP4 (channel B) is  $-1$  V from the average level of the signal at TP3 as shown in Figure 5-25.

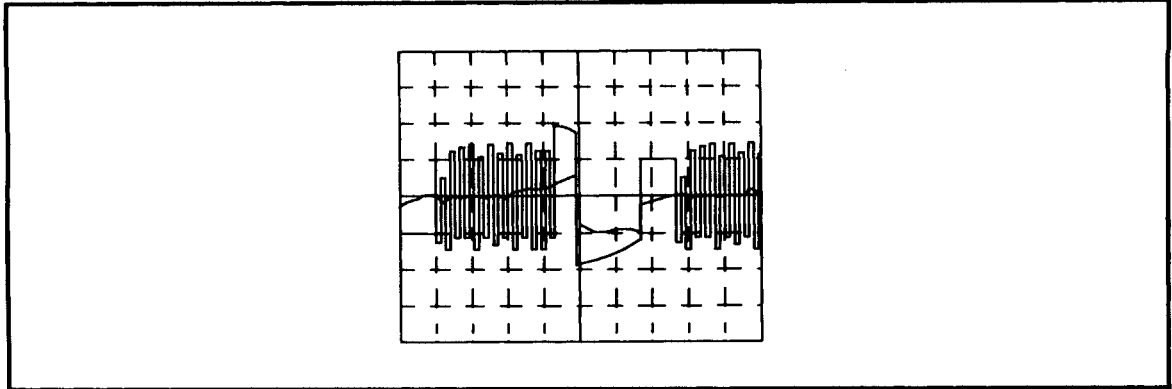

Figure 5-25. Slice Level

Observe the waveforms at test pins TP1 and TP3; adjust the variable resistor, VR4, until the blanking width is 5ms.

#### 5.7.3.5. BLANKING WIDTH

20. Leave the Oscilloscope channel A input at TP3 and connect channel B to TP1. Set the Oscilloscope controls as follows:
- Time/Div to 10 msec
  - V/Div to 5V (A and B)
  - Mode to chop
21. Adjust VR4 until the signal at TP1 (channel B) is 5 msec wide as shown in Figure 5-26.

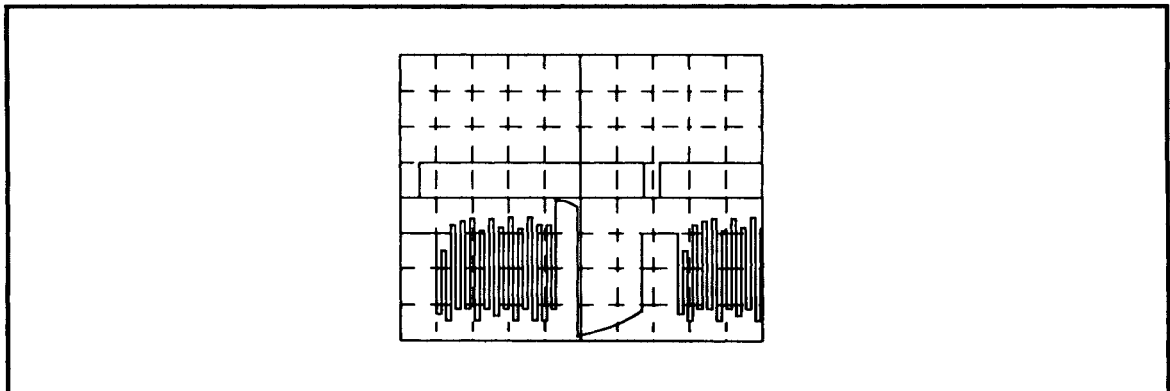

Figure 5-26. Blanking Width

22. Shut down power to the RSS-48b using the instructions provided in Section 3, paragraph 3.5.3.
23. Disconnect test equipment, replace bottom cover, and close front door.

## 5.7.4. DRUM ROTATION STOP

The following procedure is used to adjust the rotary storage drum stopping position. Figure 5-27 illustrates adjustment locations.

1. Open the front door (refer to paragraph 5.6.1.1).
2. Insert a data cartridge into the center of rotary storage drum bin A 12.
3. Insert a data cartridge into the handler's carrier (spread fingers, insert cartridge until flush against plate springs, the release fingers).
4. Rotate the drum, elevator, and carrier until the two data cartridges are aligned (flush with slight (but equal) gap between edges).
5. Verify the tab on top of the drum is aligned with the sensor on the Drum Slit Sensor CCA.
  - If incorrect, loosen the screws holding the Sensor CCA/Bracket combination and move until properly aligned. Retighten screws.
6. Remove data cartridges and close the front door.

## 5.7.5. ELEVATOR HORIZONTAL AND HEIGHT

The following procedure is used to adjust the elevator horizontal and height positions. Figure 5-27 illustrates adjustment locations.

### 5.7.5.1. HORIZONTAL POSITION

1. Open the front door (refer to paragraph 5.6.1.1).
2. Insert a data cartridge into the center of rotary storage drum bin A 12.
3. Insert a data cartridge into the handler's carrier (spread fingers, insert cartridge until flush against plate springs, the release fingers).
4. Rotate the drum, elevator, and carrier until the upper edge of both data cartridges is aligned.
  - If the upper edge is not aligned:
    - rotate the drum, elevator, and carrier until the left upper corners of the two data cartridges is aligned.
    - clamp the inner drive belt so it cannot move.
    - loosen the four hex drive screws holding the elevator motor flange.
    - rotate the outer drive shaft until the upper edge of both data cartridges are aligned.
    - tighten the four hex drive screws holding the motor flange.
    - remove the clamp.

## 5.7.5.2. HEIGHT POSITION

### WARNING

The next steps are performed with power applied to the RSS-48b and the front door open. Both electrical shock hazard and mechanical hazard from moving parts exist when operating the RSS-48b with the door open. Take necessary precautions to protect yourself from both hazards during the remainder of this procedure.

### WARNUNG

Die nächsten Schritte werden bei eingeschalteter RSS-48b und geöffneter Fronttür durchgeführt. Sowohl die Gefahr eines elektrischen Schlags als auch die Gefahr durch sich bewegende Teile besteht, wenn die RSS-48b bei offener Tür betrieben wird. Die notwendigen Vorsichtsmaßnahmen zum Schutz gegen beide Gefahren sind für den Rest dieses Vorgangs zu treffen.

### AVERTISSEMENT

Les opérations suivantes doivent être effectuées avec le RSS-48b sous tension et le panneau avant ouvert. Il existe dans ces conditions des dangers d'électrocution et des risques de blessures provenant de pièces mécaniques en mouvement. Prendre les précautions nécessaires pour se protéger de ces deux dangers pendant le reste de cette opération.

5. Locate the interlock switch on the upper right side of the RSS-48b and pull the plunger to the full out position (interlock defeated).
6. While observing the elevator, power-up the RSS-48b using the instructions provided in Section 3, paragraph 3.5.1. Verify that the elevator does not move up or down when power is applied.
  - If the elevator moves up or down when power is applied, note direction and amount of movement and proceed as follows:
    - power down the RSS-48b using the instructions provided in Section 3, paragraph 3.5.3.
    - rotate the drum, elevator, and carrier until the upper edge of both data cartridges is again aligned.
    - loosen the nine screws holding the slit board and move the board up or down to correct alignment. Retighten screws.
    - repeat step until no movement is observed when power is applied.
7. Remove data cartridges and close the front door.

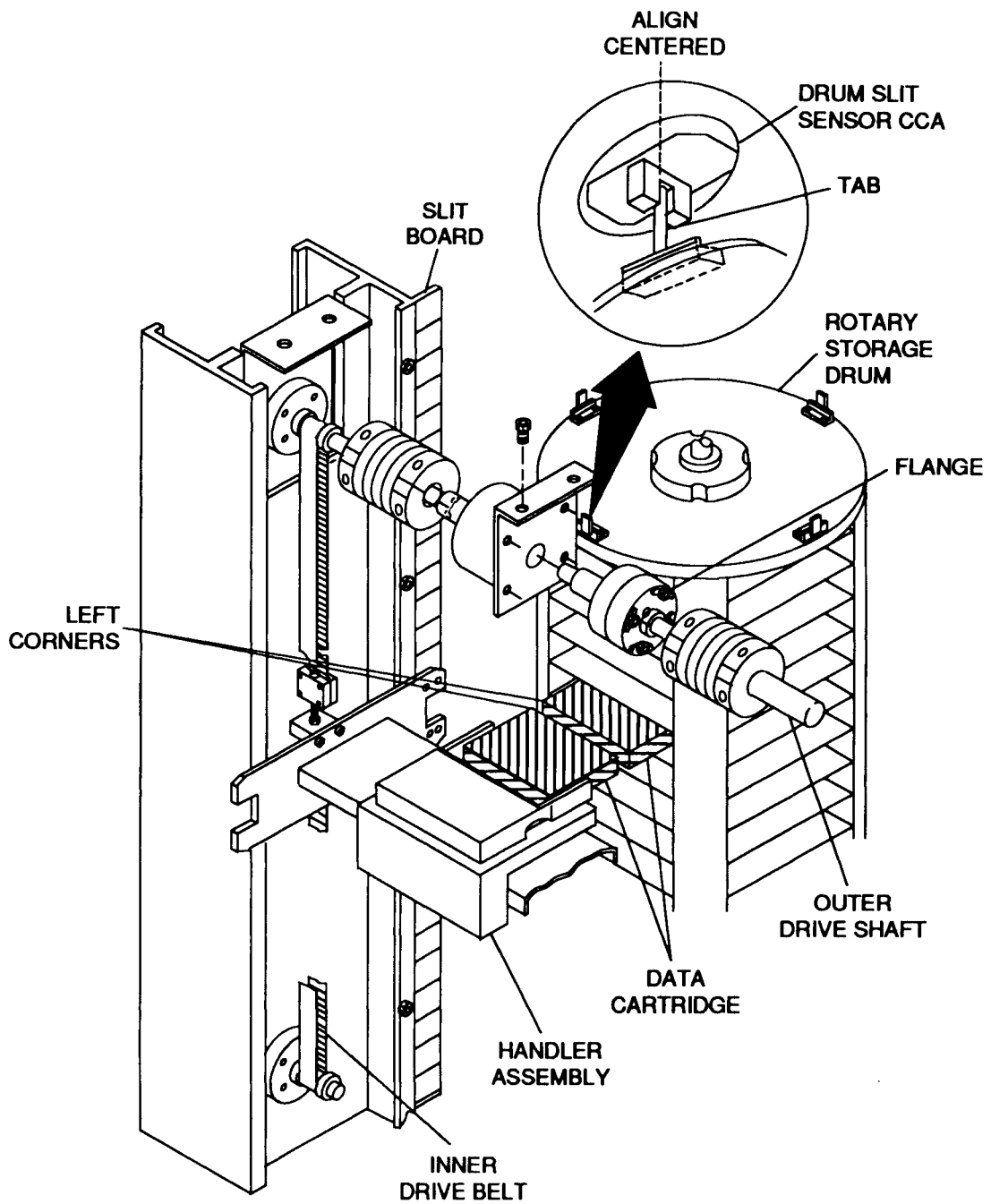

Figure 5-27. Drum and Elevator Adjustments



# **6. ILLUSTRATED PARTS BREAKDOWN**

## **6.1. GENERAL**

The parts list contains all replaceable assemblies and parts indented under their respective assemblies and subassemblies. Common hardware is not listed, but special and consumable hardware items are listed and illustrated. An explanation of each column contained in the parts listing table is provided in the following paragraph.

### **6.1.1. FIGURE NUMBER**

This column lists the figure number of the illustration on which a particular part can be found.

### **6.1.2. INDEX NUMBER**

This column lists the index number of an item which is used to locate the item in the illustration.

### **6.1.3. MANUFACTURER'S PART NUMBER**

This column lists the manufacturer's part number. In some cases more than one manufacturer can supply an "or equal" part, but the intent is to show only one outside source.

**NOTE** In most instances where standard hardware appears in the parts list, the government specification part number or government standard part number shown may identify an acceptable replacement item and not necessarily an identical replacement item.

### **6.1.4. DESCRIPTION**

This column lists, in most cases, the approved government item name and modifiers as contained in Cataloging Handbook H6-1. In the case of standard electronic items and hardware, additional data has been added to the description to enable procurement of a replacement item from local commercial sources. In addition to the name, the description column contains the following items:

#### 6.1.4.1. Indenture

Items listed in the Parts List are indented to show their Next Higher Assembly relationship. To determine the Next Higher Assembly of an item, note the position of the first word of the description for that item. The first item directly above it whose description starts one position to the left is the Next Higher Assembly for that item. The following example shows an assembly starting in the extreme left position (first indented position) and continues down through succeeding indented positions until the last item is reached:

Equipment

- . Assembly
- . . Detail parts for assembly
- . . Subassembly
- . . . Detail parts for subassembly

#### 6.1.4.2. Reference Designator

Lists (in parentheses) the schematic, assembly, or item reference designation which is used to locate electrical and electronic assemblies and/or items in their locator illustrations and schematic diagrams.

#### 6.1.4.3. CAGE Code

Lists (in parentheses) the manufacturers code as contained in the Commercial and Government Entity (CAGE) (Cataloging Handbook H4/H8). For those items where code 28009 is used, procurement must be made from Metrum.

The CAGE codes of all items used in this equipment and contained in the parts listings are identified in paragraph 6.4.

#### 6.1.4.4. Cross-Reference Notes

Various cross-reference notes appear throughout the Parts List. They list Detail Breakdown and Next Higher Assembly illustration relationship and provide equipment configuration continuity. For example:

- (See FIG. XXX for detail breakdown) indicates where the assembly is broken down into its component parts.
- (Refer to FIG. XXX for next higher assembly) indicates where the assembly is listed under its Next Higher Assembly.

### 6.1.5. QUANTITY PER ASSEMBLY

This column lists the number of times an item is used in its next higher assembly at the location indicated by the figure and index number.

### 6.1.6. NOTES

This column lists the number of the applicable note located at the bottom of the page.

## 6.2. RECOMMENDED SPARE PARTS LIST

Tables 6-1 and 6-2 list the recommended number of spare parts required to support an equipment for one year. The spare parts recommended were calculated on the basis of an equipment in operation for five days a week and eight hours per day or 2,000 hours of annual operation.

Table 6-1, Operator's Level Recommended Spare Parts List, contains the spare parts required to maintain the equipment with a maximum down-time of one hour. Operator's level maintenance is defined as maintenance performed by the operator and/or technician at the location of the equipment and within the down-time criterion.

Table 6-2, Intermediate/Bench Level Recommended Spare Parts List, contains the spare parts required to maintain the equipment where down-time is not a factor. Intermediate/Bench Level Maintenance is defined as maintenance performed by a technician in a repair facility and consists of tasks which exceed down-time of one hour.

Table 6-1. Operator's Level Recommended Spare Parts List

Part Number	Description	Cage Code	Qty Per Assy	Spares
70430469A	Air Filter Element	8Z476	1	—
70404394A	Handler Rubber Fingers	8Z476	2	—

Table 6-2. Intermediate Bench Level Recommended Spare Parts List (1 of 2)

Part Number	Description	Cage Code	Qty Per Assy	Spares
70402043A	Drum Slit Sensor Tabs (4/Set)	8Z476	4	—
70405397C	Cassette Sensor Switch Spring	8Z476	1	—
74430434A	Handler Z-Axis Motor	8Z476	1	—
845821000	Cassette Sensor Switch	8Z476	1	—
UCL005061	50 Pin Flat Cable Assy	8Z476	1	—
70402906E	Coil Spring (2 Sets)	8Z476	1	—
70403886D	Handler Plate Spring (2 Sets)	8Z476	1	—
70404394A	Handler Rubber Fingers (2 Sets)	8Z476	1	—
70430469A	Air Filter Element	8Z476	1	—
857130004	Power Supply #1 (5 & 12 Volt)	8Z476	1	—
857100124	Power Supply #2 (5 Volt)	8Z476	1	—
857100124	Power Supply #3 (24V)	8Z476	1	—

## 6.3. ORDERING INFORMATION

When ordering spare or replacement parts from Metrum, always specify the following:

- a. Equipment Name
- b. Metrum Model Number
- c. Metrum Serial Number
- d. Part Description
- e. Metrum Part Number
- f. Quantity Required

Send all orders to the following address:

**Metrum, Inc.**  
**P.O. Box 5227**  
**Denver, Colorado 80217-5227**  
**Attn: Customer Service**  
**Phone: 303-773-4700**

## 6.4. PARTS LIST AND ILLUSTRATIONS

The tables in Section 6 list all recommended replaceable assemblies and/or parts used in the equipment. These tables provide a means of locating spare or replacement part information through the use of appropriate references to their related illustrations.

## 6.5. MANUFACTURERS

The following is a numeric list of CAGE codes appearing in the parts list along with the name and address of the manufacturer.

**CODE NAME AND ADDRESS**

28009	METRUM, Inc. 4800 East Dry Creek Road Littleton, CO 80122
51279	Power Components Corporation P.O. Box 6626 Santa Rosa, Ca 95406
8Z476	ASACA/Shibasoku Corporation of America 12509 Beatrice Street Los Angeles, CA 90066

## 6.6. ASSEMBLY INTERCHANGEABILITY LIST

The following list contains the interchangeability of assemblies used in this equipment. This list is in alphabetical order by assemblies with the latest assembly part number listed last. The definition for each code at the right of each part number is at the bottom of each page.

Assembly Interchangeability List

Description	Part Number	Code

Code	Definition
A	Complete two way interchangeability between part number and previous part number.
B	Part number is interchange-backward with previous part number: old part numbers are interchangeable forward but with degraded performance or reliability.
C	Part number is interchangeable backward with previous part number: old part numbers are not interchangeable forward.
D	Part number is not interchangeable backward with any previous part numbers and old part numbers are not interchangeable forward.

## 6.7. RECOMMENDED LEVEL OF MAINTENANCE LIST

The following list contains the Recommended Level of Maintenance on assemblies and subassemblies used in this equipment.

The following definitions listed below are definitions of the notes which appear at the bottom of each page of this list.

Recommended Level of Maintenance List (1 of 2)

Metrum Part No.	Description	Notes								
		1	2	3	4	5	6	7	8	9
202014-2	Handler Assembly		X					X		
651043-2	Sensor 1 CCA	X			X					
651258-2	Drum Slit Sensor CCA	X			X					
651514-2	Sensor 2 CCA	X			X					
651515-2	Drive and I/O CCA	X			X					
651516-1482	Pulse Motor Control 1 CCA	X			X					
651516-2482	Pulse Motor Control 2 CCA	X			X					
651798-2	Drum Gray Code Sensor CCA				X					
651901-482	CPU CCA	X			X					
651902-2	FIP I/O CCA	X			X					
651904-2	Operational Panel CCA							X		
651979-2	Elevator Gray Code Sensor CCA				X					
652031-2	Middle Sensor CCA				X					
652032-2	Front and Rear Sensor CCA's				X					
74430196A	Y-Axis Motor Assembly			X						
74430434A	Z-Axis Motor Assembly			X						
74430616A	Drum Motor Assembly			X						
855929650	Power Transformer Assembly									
857100124	Power Supply Assembly #2	X			X					
857100125	Power Supply Assembly #3	X			X					
857130004	Power Supply Assembly #1	X			X					
861300008	Display Assembly				X					
86680031A	Pulse Motor Driver (Elevator)	X			X					
86680031B	Pulse Motor Driver Drum			X			X			

**NOTE****DEFINITION**

- 1 **Recommended Spare**: An item deemed necessary to have available to facilitate a timely and cost effective equipment repair. Included should be all CCA's and items critical to mission success.
- 2 **Mandatory Factory Repair (non-repairable)**: An item that cannot be repaired in the field because of a lack of special tooling and/or test equipment.
- 3 **Expendable (non-repairable) Throw Away**: An item that cannot be repaired because of the way it is assembled.
- 4 **Expendable (repairable) Throw Away**: An item that can be repaired in a time of need but is generally not because it is not cost effective.
- 5 **Repairable to Component Level**: An item that can be repaired by replacing individual components.
- 6 **Recommended Factory Repair**: An item that is recommended to be returned to the factory for repair.
- 7 **Repair Exchange**: An item that is normally carried in stock at the factory. Contact the factory for availability of repair exchange items. (New item may be ordered from the factory in lieu of repair exchange items.)
- 8 **Limited Repair**: An item that can be repaired by replacing a select number of individual components.

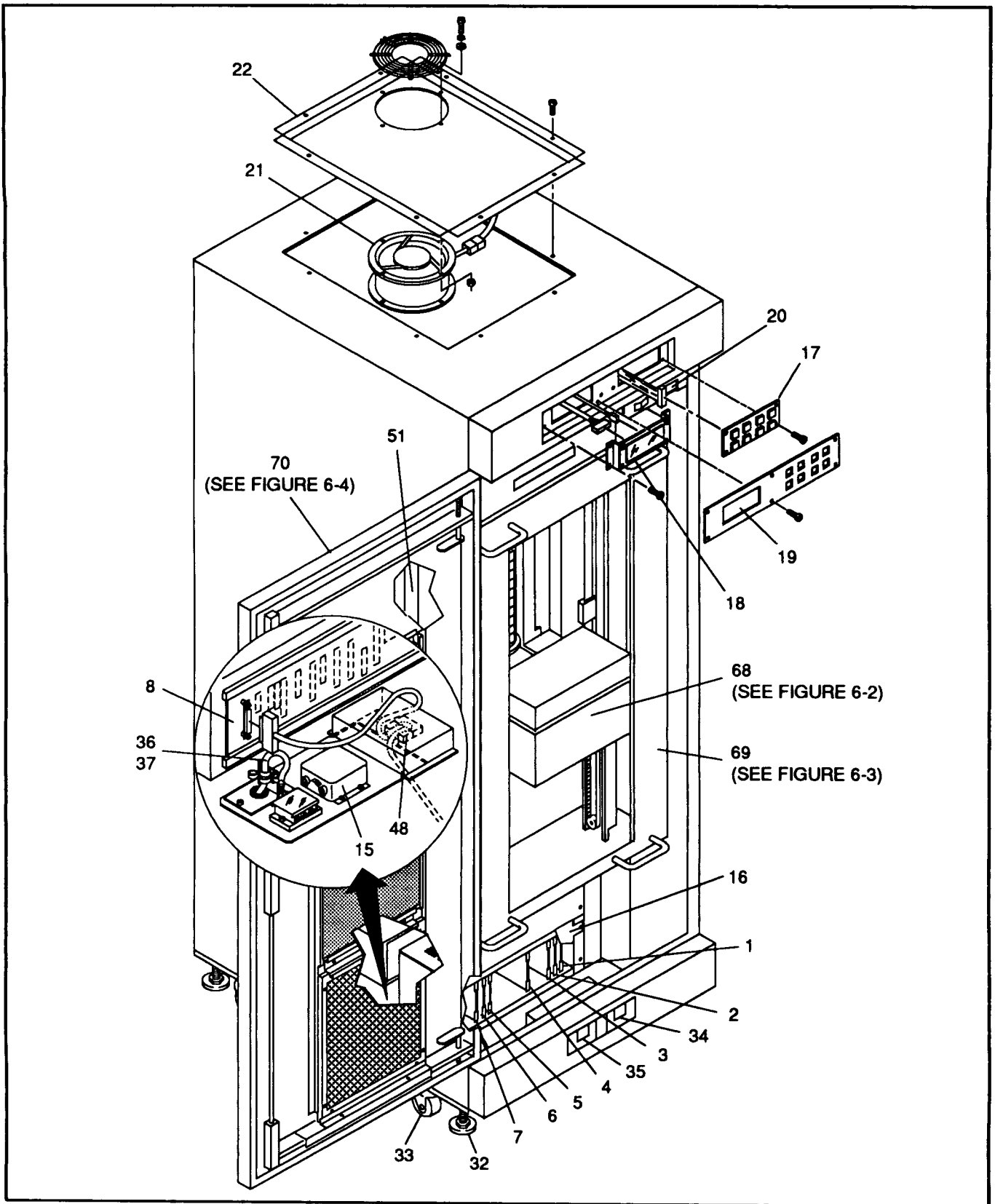

Figure 6-1. Rotary Storage RSS-48b (Sheet 1 of 2)

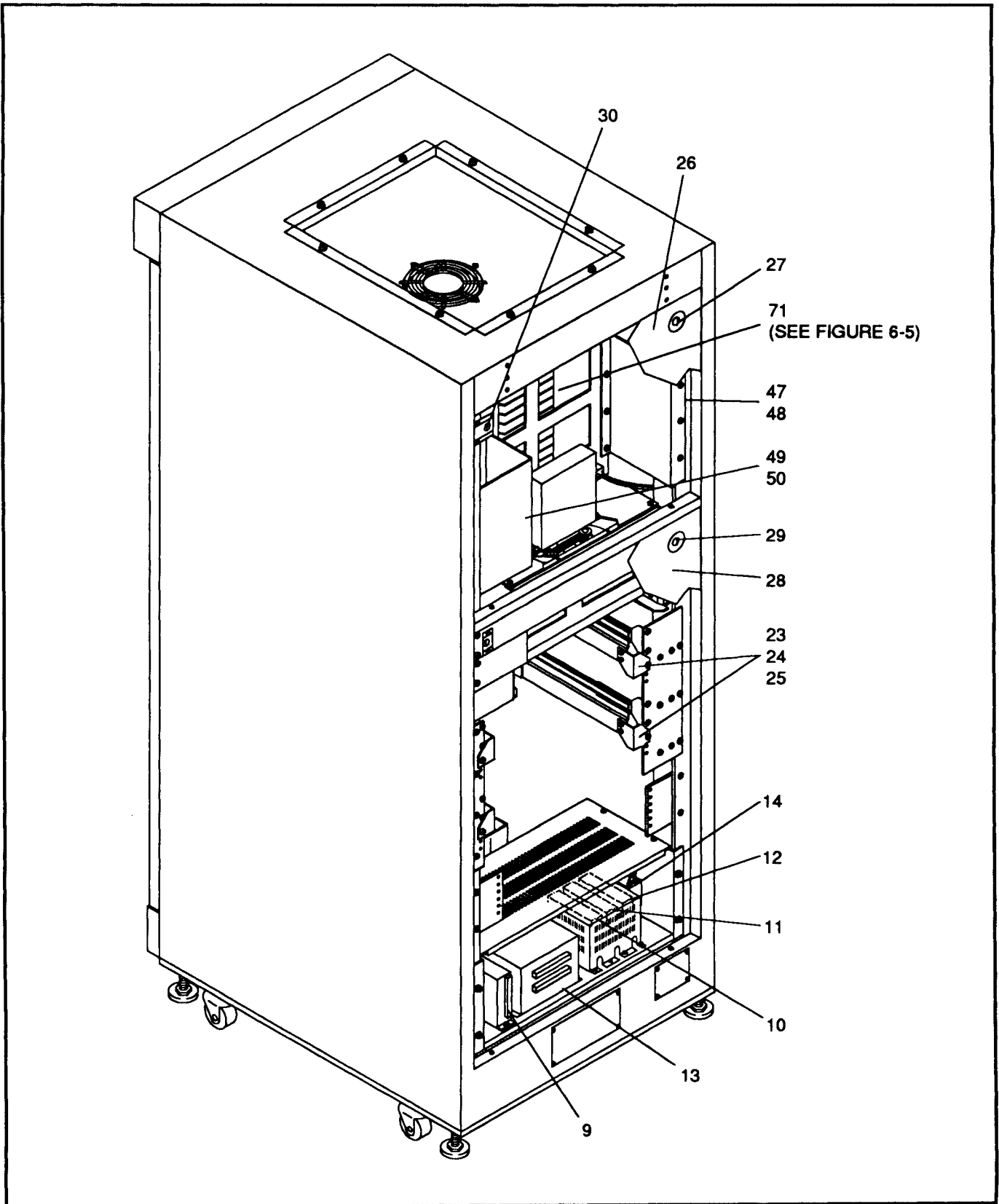

Figure 6-1. Rotary Storage RSS-48b (Sheet 2 of 2)

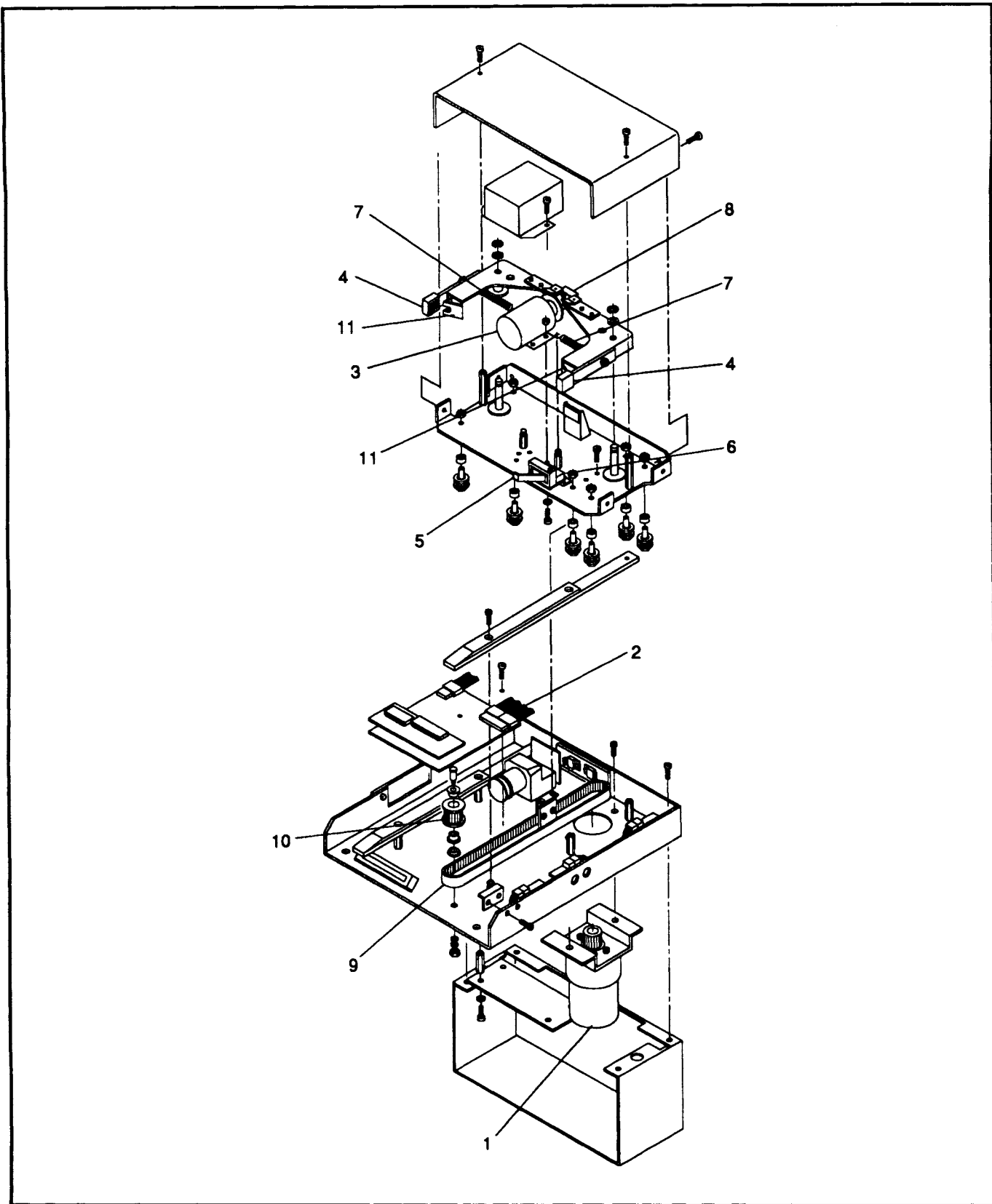

Figure 6-2. Handler Assembly

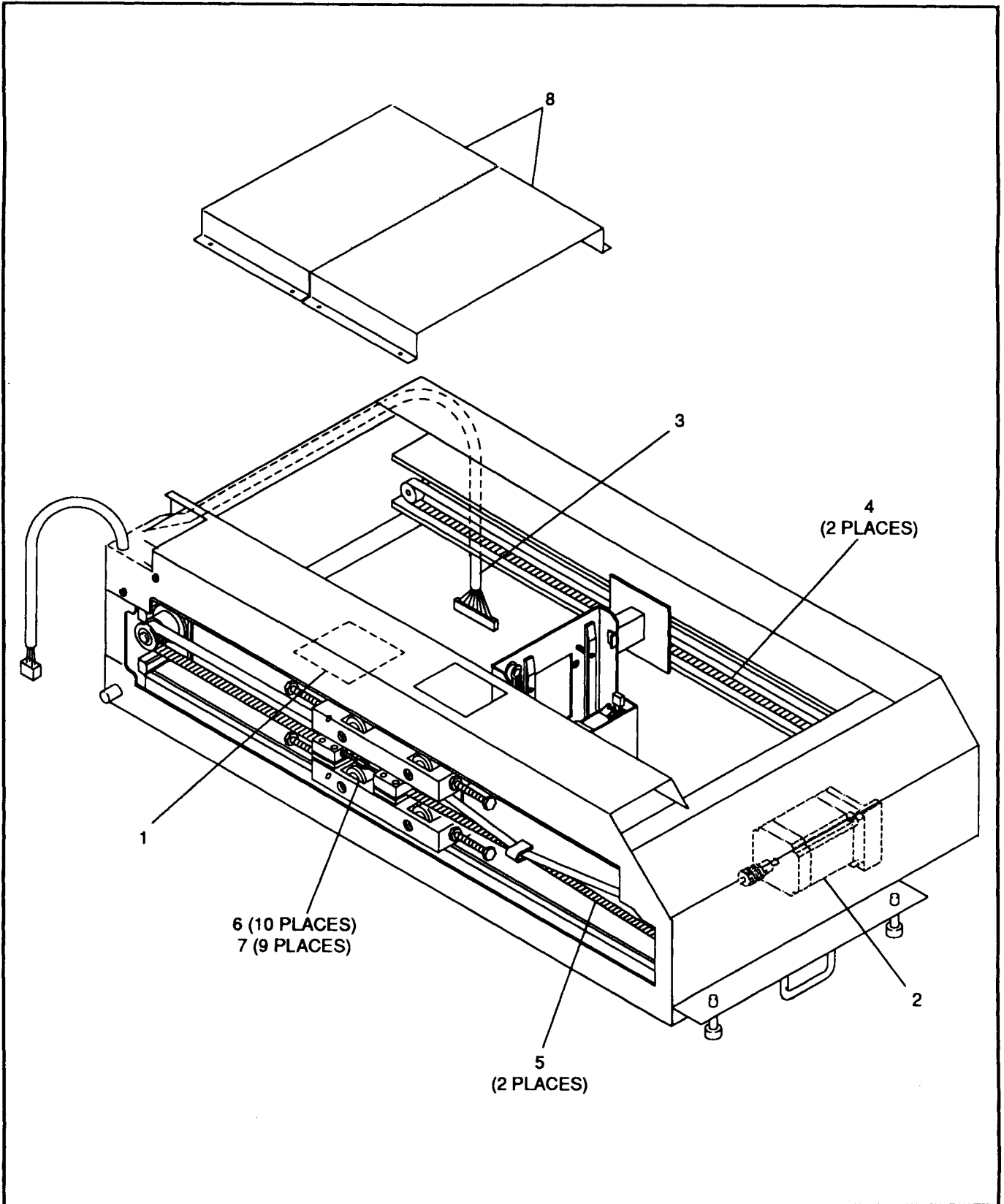

Figure 6-3. Elevator Assembly

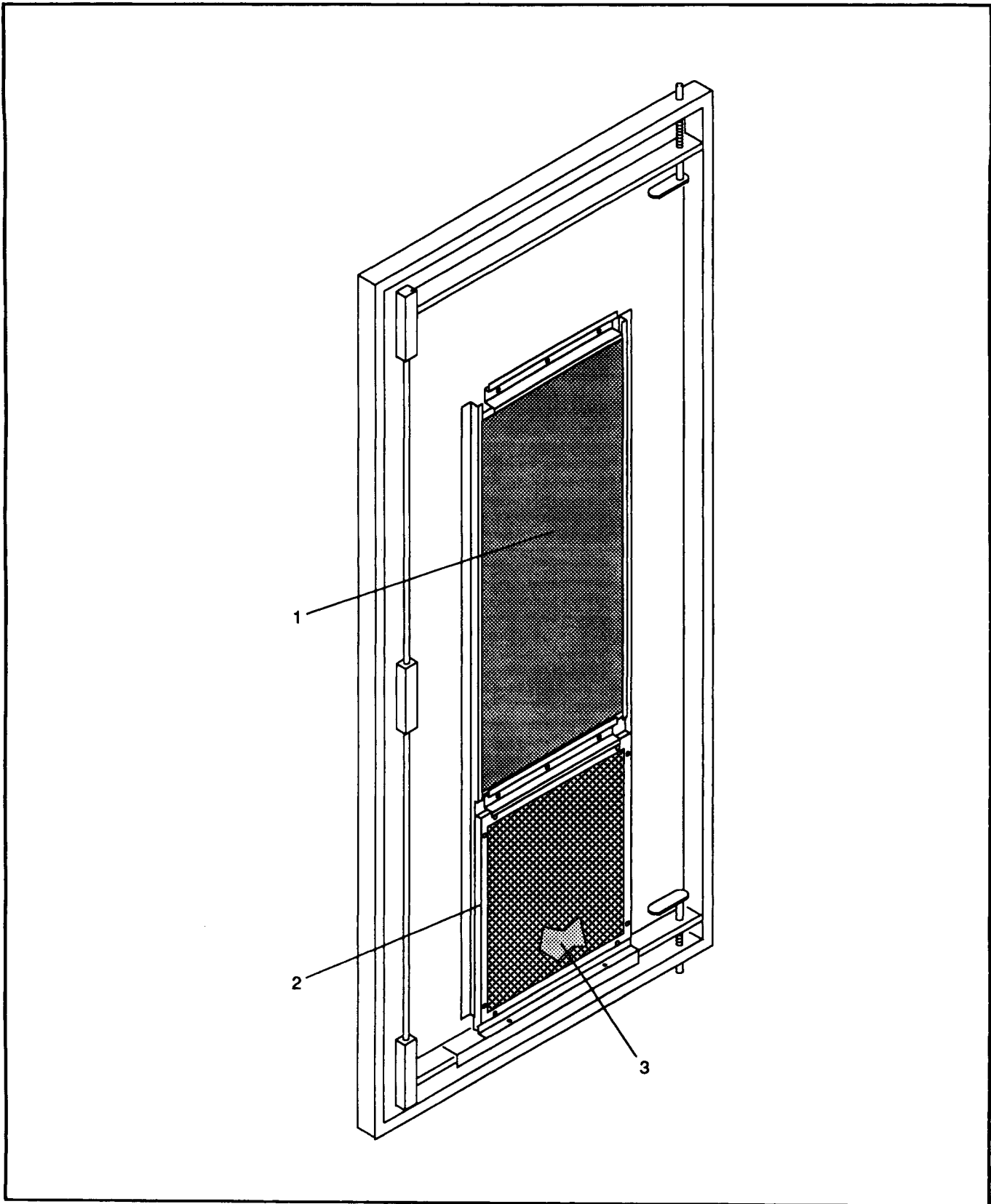

Figure 6-4. Front Door Assembly

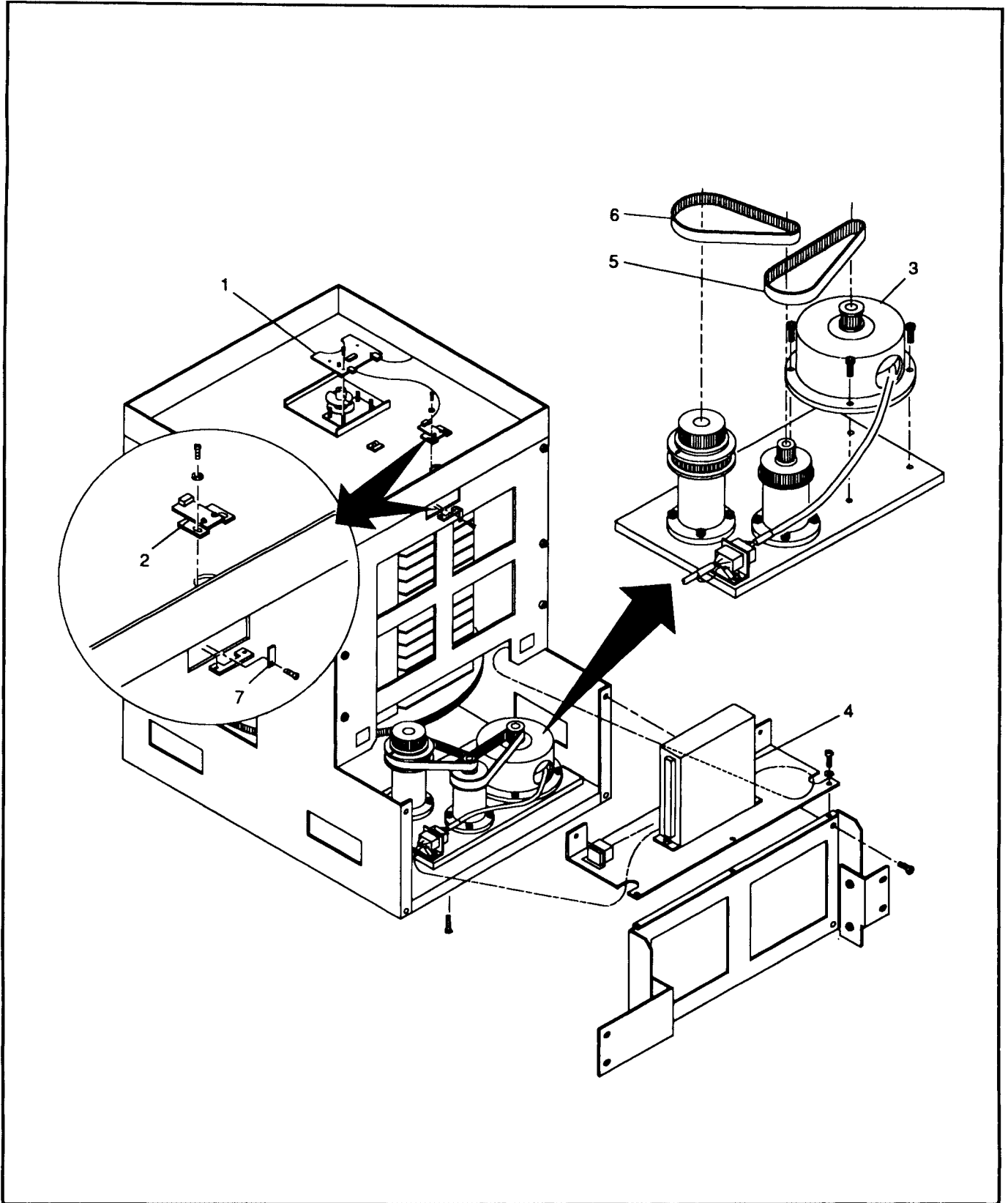

Figure 6-5. Drum Assembly

Table 6-3. RSS-48b Rotary Storage Subsystem

Figure and Index No.	Part Number	Description							QTY/ ASSY	Note
		1	2	3	4	5	6	7		
6-1-	RSS-48b	DATA STORAGE SYSTEM (8Z476) .....							1	
-1	651901-482	. CIRCUIT CARD ASSEMBLY, CPU (A1) .....							1	
		(8Z476)								
-2	651043-2	. CIRCUIT CARD ASSEMBLY, Sensor one .....							1	
		(A2)(8Z476)								
-3	651514-2	. CIRCUIT CARD ASSEMBLY, Sensor two .....							1	
		(A3)(8Z476)								
-4	651515-2	. CIRCUIT CARD ASSEMBLY, Drive and .....							1	
		I/O (A4)(8Z476)								
-5	651902-2	. CIRCUIT CARD ASSEMBLY, FIP I/O (A5) .....							1	
		(8Z476)								
-6	651516-1482	. CIRCUIT CARD ASSEMBLY, Pulse motor .....							1	
		control one (A6)(8Z476)								
-7	651516-2482	. CIRCUIT CARD ASSEMBLY, Pulse motor .....							1	
		control two (A7)(8Z476)								
-8	651512-2	. CIRCUIT CARD ASSEMBLY, .....							1	
		motherboard (8Z476)								
-9	866800031A	. PULSE MOTOR DRIVER, Elevator (8Z476).....							1	
-10	857130004	. POWER SUPPLY ASSEMBLY (1), ±12V .....							1	
		(8Z476)								
-11	857100124	. POWER SUPPLY ASSEMBLY (2), ±5V .....							1	
		(8Z476)								
-12	857100125	. POWER SUPPLY ASSEMBLY (3), ±24V .....							1	
		(8Z476)								
-13	855929650	. TRANSFORMER, Power (8Z476).....							1	
-14	868800025	. FILTER, Line (FL1,FL3) (8Z476) .....							2	
-15	868800025	. FILTER, Line (FL4) (8Z476).....							1	
-16	70430612A	. SHIELD, Circuit card (8Z476) .....							1	
-17	651904-2	. CIRCUIT CARD ASSEMBLY, Operational .....							1	
		panel (A9)(8Z476)								
-18	861300008	. DISPLAY ASSEMBLY, FIP (8Z476) .....							1	
-19	70430431A	. WINDOW, Display (8Z476) .....							1	
-20	845475000	. SWITCH, Door, Interlocking (8Z476).....							1	
-21	866800022	. FAN, Cooling, 24V.....							1	
-22	70430636A	. PANEL, Blank, fan (8Z476) .....							1	
-23	70419553A	. RAIL KIT, Slide - VLDS (8Z476) .....							2	
	70430255A	. . STOPPER, Right rear (8Z476) .....							1	
	70430256A	. . STOPPER, Left rear (8Z476) .....							1	
-24	URS04852A	. RAIL KIT, Slide - RSP-2150 (8Z476) .....							2	
	70430252A	. . STOPPER, Right rear (8Z476) .....							1	
	70430252B	. . STOPPER, Left rear (8Z476) .....							1	
-25	URS04850A	. SLIDE ASSEMBLY, Adjust (pair) (8Z476) .....							2	

Table 6-3. RSS-48b Rotary Storage Subsystem

Figure and Index No.	Part Number	Description							QTY/ ASSY	Note
		1	2	3	4	5	6	7		
-26	70230008A	.							1	
-27	70491430B	.							2	
-28	70230000B	.							1	
-29	70491430B	.							2	
-30	70491430E	.							4	
-31	70491411A	.							1	
-32	70491235A	.							4	
-33	70491236A	.							4	
-34	867290002	.							1	
-35	867290002	.							1	
-36	16823287-001	.							1	
-37	16823287-002	.							1	
-38	88020100	.							1	Not Shown
-39	88010801	.							1	Not Shown
-40	88010713	.							1	Not Shown
-41	88010721	.							1	Not Shown
-42	88010740	.							1	Not Shown
-43	88010713	.							1	Not Shown
-44	88010763	.							1	Not Shown
-45	88010771	.							1	Not Shown
-46	88010732	.							1	Not Shown
-47	88010780	.							1	Not Shown
-48	ESD-Q-45	.							1	
-49	70419915A	.							1	Not Shown
-50	70430087A	.							1	Not Shown
-51	70419915B	.							1	Not Shown
-52	70430088A	.							1	Not Shown
-53	70419920A	.							1	Not Shown
-54	70420086A	.							1	Not Shown
-55	16823272-001	.							1	Not Shown
-56	S48230057	.							A/R	Not Shown
-57	70491802A	.							2	Not Shown
-58	70430089A	.							2	Not Shown
-59	70408024A	.							1	Not Shown
-60	70423637A	.							1	Not Shown
-61	70430901A	.							1	Not Shown
-62	70423638A	.							1	Not Shown
-63	70423639A	.							1	Not Shown
-64	70430581A	.							1	Not Shown

Table 6-3. RSS-48b Rotary Storage Subsystem

Figure and Index No.	Part Number	Description							QTY/ ASSY	Note
		1	2	3	4	5	6	7		
-65	Order by Description	. .	INDICATOR, Tip-and-tell (28009).....						1	Not Shown
-66	Order by Description	. .	INDICATOR, 25G Shock (28009).....						1	Not Shown
-67	Order by Description	. .	INDICATOR, 50G Shock (28009).....						1	Not Shown
-68	202014-2	. .	HANDLER ASSEMBLY (Complete) (8Z476).....						1	
6-2-1	74430434A	. .	MOTOR, Z-Axis (8Z476).....						1	
-2	880200016	. .	CABLE, Flat ribbon (8Z476) .....						1	
-3	87200002	. .	SOLENOID, Plunger (8Z476) .....						1	
-4	70404394A	. .	RUBBER FINGER (8Z476) .....						2	
-5	70405397C	. .	SPRING, Switch (8Z476).....						1	
-6	845821000	. .	SWITCH, Spring (Cartridge) (8Z476).....						1	
-7	70402906E	. .	SPRING, Coil (8Z476).....						2	
-8	70408490A	. .	PAD, Solenoid (8Z476) .....						1	
-9	70491604G	. .	DRIVE BELT, Timing (8Z476) .....						1	
-10	74430892A	. .	IDLER ASSEMBLY (8Z476).....						1	
-11	70403886D	. .	SPRING, Plate (8Z476).....						2	
6-1-69	No Number	. .	ELEVATOR ASSEMBLY (8Z476).....						1	
6-3-1	651979-2	. .	CIRCUIT CARD ASSEMBLY, Elevator .....						1	
			gray code sensor (A8)(8Z476)							
-2	74430196A	. .	MOTOR, Y-axis (8Z476).....						1	
-3	UCL005061	. .	CABLE ASSEMBLY, Flat ribbon 50 cond.....						1	
			(8Z476)							
-4	70423583A	. .	DRIVE BELT, Y-Axis, inner (8Z476) .....						2	
-5	70423583B	. .	DRIVE BELT, Y-Axis, outer (8Z476).....						2	
-6	70408425A	. .	GUIDE ROLLER, Center (8Z476).....						10	
-7	70408425B	. .	GUIDE ROLLER, Eccentric (8Z476).....						9	
-8	70430621B	. .	PANEL, Blank, drive (8Z476).....						2	
6-1-70	70230011A	. .	FRONT DOOR ASSEMBLY (Complete).....						1	
			(8Z476)							
6-4-1	70430353A	. .	WINDOW, Front door (8Z476).....						1	
-2	74430617A	. .	FILTER ASSEMBLY, Air (8Z476).....						1	
-3	70430469A	. .	FILTER ELEMENT (8Z476).....						1	
6-1-71	No Number	. .	DRUM ASSEMBLY (8Z476).....						1	
6-5-1	651798-2	. .	CIRCUIT CARD ASSEMBLY, Drum gray ....						1	
			code sensor (8Z476)							
-2	651258-2	. .	CIRCUIT CARD ASSEMBLY, Drum slit .....						1	
			sensor (8Z476)							
-3	74430616A	. .	MOTOR, Drum (8Z476).....						1	
-4	866800031B	. .	PULSE MOTOR DRIVER, Drum (8Z476) .....						1	
-5	70491622A	. .	DRIVE BELT, Drum, motor (8Z476).....						1	
-6	70491622B	. .	DRIVE BELT, Drum, gearbox (8Z476).....						1	
-7	70402043A	. .	TAB, Slit sensor (8Z476).....						1	

# 7. PACKAGING

---

## 7.1. GENERAL

This section provides instructions for repackaging the RSS-48b for storage or shipment.

### WARNING

These instructions are for use by qualified personnel only. To avoid electric shock, do not remove covers or perform procedures unless you are qualified to do so.

### WARNUNG

Diese Anleitungen ist ausschließlich für qualifiziertes Personal bestimmt. Um einen elektrische Schlag zu vermeiden, darf nur qualifiziertes Personal Abdeckungen entfernen oder Arbeiten durchführen.

### AVERTISSEMENT

Ces instructions s'adressent à du personnel compétent seulement. Pour éviter tout choc électrique, ne retirez pas les garnitures et n'entrenez aucune procédure à moins d'être qualifié pour le faire.

### CAUTION

This equipment contains ESDS devices. Proper ESDS device handling procedures must be followed. Refer to the ESDS DEVICE HANDLING information at the front of this manual.

## 7.2. SAFETY PRECAUTIONS

### 7.2.1. ELECTRICAL SAFETY

#### WARNING

HIGH LEAKAGE CURRENT in excess of 5 ma. Earth connection essential before connecting supply.

#### WARNUNG

Kriechstrom von mehr als 5 mA kann vorhanden sein.

#### AVERTISSEMENT

Un courant d'excitation de plus de 5 mA peut exister.

**WARNING**

The RSS-48b contains dangerous high voltages. CARELESS OR IMPROPER HANDLING CAN RESULT IN SERIOUS ELECTRIC SHOCK. Never remove power cables with power applied.

**WARNUNG**

Die RSS-48b enthält gefährliche Hochspannungen. UNACHTSAME ODER UNSACHGEMÄSSE HANDHABUNG KANN ZU EINEN ERNSTHAFTEN ELEKTRISCHEN SCHLAG FÜHREN. Niemals unter Spannung stehende Netzkabel entfernen.

**AVERTISSEMENT**

Le RSS-48b contient des composants sous haute tension dangereux. UNE MANIPULATION INADÉQUATE OU NE RESPECTANT PAS LES PRÉCAUTIONS VOULUES PRÉSENTE DE GRAVES RISQUES D'ÉLECTROCUTION. Ne jamais ôter les câbles électriques quand l'unité est sous tension.

**7.2.2. MECHANICAL SAFETY****WARNING**

A minimum of 2 persons are required to pack the RSS-48b. The unit weighs approximately 800 lbs (360 kg) and, when the leveling pads are retracted, will roll freely on its built-in rollers. USE EXTREME CAUTION when rolling the RSS-48b up the ramp. If the RSS-48b is allowed to roll back down the ramp uncontrolled, serious bodily injury and/or equipment damage may result. Read these instructions completely prior to packing the RSS-48b.

**WARNUNG**

Mindestens 2 Personen sind zum Verpacken der RSS-48b erforderlich. Die Einheit wiegt ca. 360 kg (800 Pfund) und läuft frei auf den eingebauten Rollen, wenn die Ausrichtungskonsolen eingezogen sind. ÄUSSERSTE VORSICHT WALTEN LASSEN, wenn die RSS-48b die Rampe hinaufgerollt wird. Wenn die RSS-48b unkontrolliert auf der Rampe zurückrollt, kann das zu ernsthafter Körperverletzung bzw. Geräteschaden führen. Die Verpackungsanleitungen in diesem Handbuch oder an der Seite der Kiste vor dem Verpacken der RSS-48b vollständig lesen.

**AVERTISSEMENT**

Il faut au minimum 2 personnes pour emballer le RSS-48b. L'unité pèse environ 360 kg (800 lbs) et, quand le dispositif de mise à niveau est rétracté, roule librement sur ses roulettes incorporées. EXERCER UNE EXTRÊME PRUDENCE lorsque l'on fait rouler le RSS-48b sur la rampe de chargement. Si on laisse le RSS-48b redescendre la rampe sans le contrôler, on s'expose à des blessures et/ou à des dégâts matériels graves. Lire toutes les instructions d'emballage contenues dans le présent manuel ou figurant sur le côté de la caisse avant d'emballer le RSS-48b.

## 7.3. EQUIPMENT REQUIRED

Table 2-1 provides a list of recommended tools and test equipment required for use when packaging the RSS-48b.

Table 7-1. Required Equipment

DESCRIPTION	MODEL	USE*
Flat Bladed Screwdriver	N/A	P
Hex-drive set (2.5 mm to 4 mm)	N/A	P
Open end wrench set (3/8 to 5/8)	N/A	P
Open end wrench set (4 mm to 11 mm) 32 mm adj.	N/A	P
Phillips Screwdriver	N/A	P
* P=Packaging, U=Unpacking, I=Installation		

## 7.4. PACKAGING

The following instructions are provided to package the RSS-48b.

### 7.4.1. DISASSEMBLY

The following instructions are provided to disassemble the RSS-48b.

#### 7.4.1.1. Power Cable Removal

The power cable is disconnected as follows:

1. Power down the RSS-48b using the instructions provided in Section 3, paragraph 3.5.3 of this manual.
2. Reverse the instructions provided in Section 2, paragraph 2.7.2.3 of this manual to disconnect the AC power cable.

**NOTE** Once all cables have been removed, replace the access panels on the bottom and rear panel (four screws) of the RSS-48b.

#### 7.4.1.2. RS-232C Cable Removal

Reverse the instructions provided in Section 2, paragraph 2.7.4.2 of this manual to disconnect the RS-232 interconnect cable.

**NOTE** Once all cables have been removed, replace the access panels on the bottom and rear panel (four screws) of the RSS-48b.

### 7.4.1.3. Alarm Cable Removal

Reverse the instructions provided in Section 2, paragraph 2.7.5 of this manual to disconnect the external alarm cable (if connected).

**NOTE** Once all cables have been removed, replace the access panels on the bottom and rear panel (four screws) of the RSS-48b.

### 7.4.1.4. Drive Removal

Reverse the instructions provided in paragraph 2.7.3 to remove all installed tape drive(s).



Do not ship the RSS-48b with tape drives installed. Failure to remove the tape drives prior to shipment may damage both the tape drive and RSS-48b.

**NOTE** Once all cables have been removed, replace the access panels on the bottom and rear panel (four screws) of the RSS-48b.

### 7.4.1.5. Preparation for Shipment

The following instructions are provided to prepare the RSS-48b for shipment (see Fig 7-1).

1. Remove the top rear panel by rotating the fasteners until the slot is horizontal then lightly rap the upper corner with the palm of your hand.
2. Install the right rear shipping bracket (four M4 x 10 and three M5 x 10 hex drive screws and washers).
3. Install the left rear shipping bracket (four M4 x 10 and three M5 x 10 hex drive screws and washers). Replace the top rear panel.
4. Open the front door.



A minimum of 2 persons are required to perform the next step. If the Cartridge Loader Assembly is allowed to drop uncontrolled, serious bodily injury and/or equipment damage may result.



Mindestens 2 Personen sind zur Ausführung des nächsten Schrittes erforderlich. Wenn die Patronenladeeinheit unkontrolliert fallen gelassen wird, kann das zu ernsthafter Körperverletzung bzw. Geräteschaden führen.



Il faut au minimum 2 personnes pour effectuer l'opération suivante. Si on laisse tomber l'ensemble de chargeur à cartouche, on s'expose à des blessures et/ou à des dégâts matériels graves.

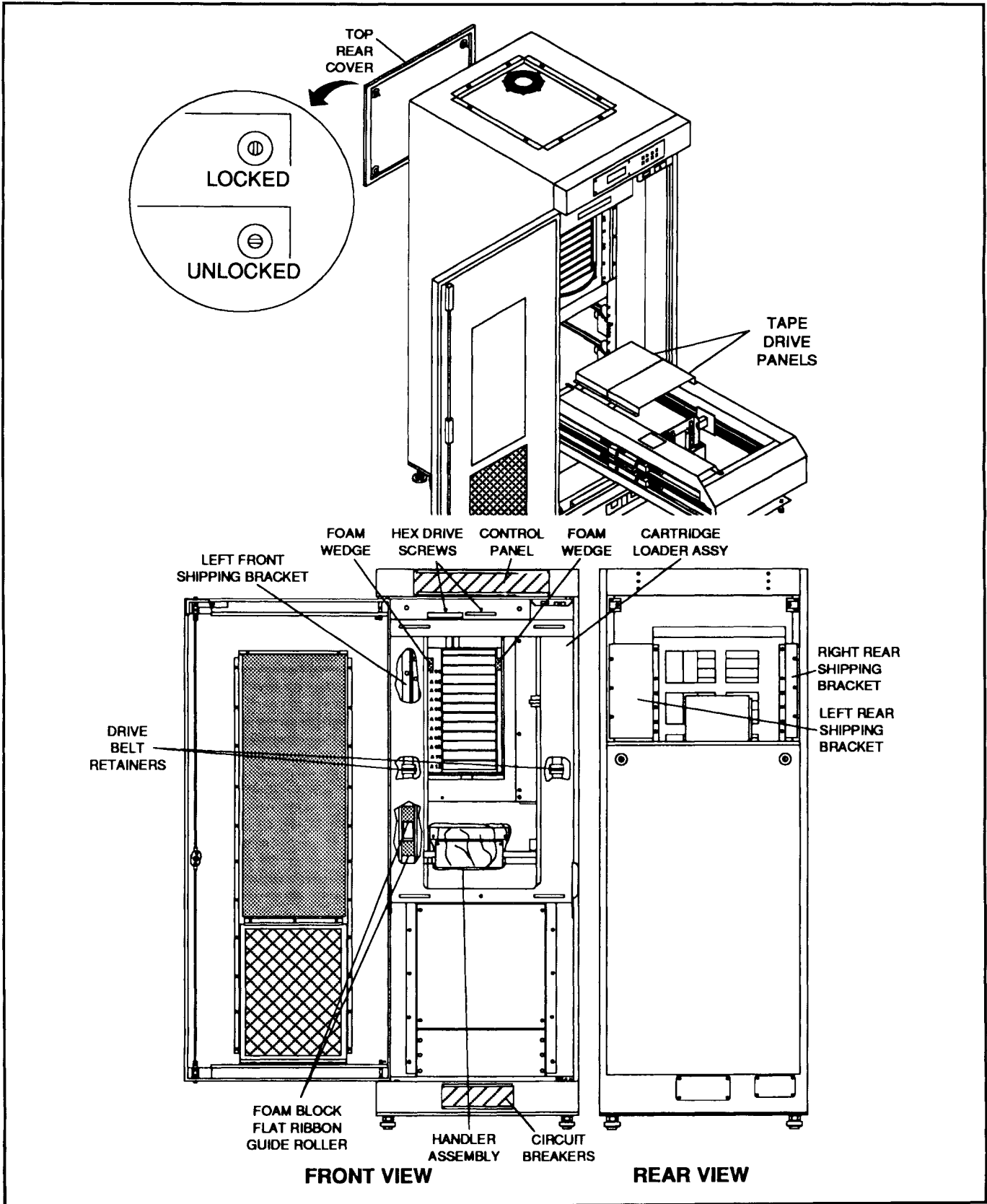

Figure 7-1. Preparation for Shipment

5. Loosen the two knurled fastening screws and two hex drive screws and lower the Cartridge Loader Assembly to the floor. While lowering the Cartridge Loader Assembly, make sure the cable harness on the lower left corner is free.
6. Install the left front shipping bracket (four M4 x 10 and four M5 x 10 hex drive screws and washers).
7. Place a  $3\frac{1}{2} \times 1\frac{1}{2} \times \frac{1}{2}$ " foam block below and a  $4 \times 3\frac{3}{4} \times 1\frac{7}{8}$ " foam block above the Flat Ribbon Guide Roller as shown.
8. Place two  $5\frac{5}{8} \times 2 \times 1$ " foam wedges to secure the drum as shown.
9. Raise the Cartridge Loader Assembly and secure with knurled fastening screws. Install two M5 x 10 hex drive screws and washers as shown.
10. Lower and center the Handler Assembly and secure using commercial grade  $\frac{1}{8}$ " ESD cushioning material and 2" mailing tape. Place drive belt retainers as shown.
11. Close the front door.
12. Tape cardboard over the system and drive circuit breakers and control panel areas as shown.
13. Wrap any accessories, including the power cord, RS-232C interconnect cable, and keys in commercial grade  $\frac{1}{8}$ " cushioning material and place in the accessory shipping box.

## 7.4.2. PACKING

The following instructions are provided to package RSS-48b for storage or shipment.

### WARNING

A minimum of 2 persons are required to pack the RSS-48b. The unit weighs approximately 800 lbs (360 kg) and, when the leveling pads are retracted, will roll freely on its built-in rollers. **USE EXTREME CAUTION** when rolling the RSS-48b up the ramp. If the RSS-48b is allowed to roll back down the ramp uncontrolled, serious bodily injury and/or equipment damage may result. Read these instructions completely prior to packing the RSS-48b.

### WARNUNG

Mindestens 2 Personen sind zum Verpacken der RSS-48b erforderlich. Die Einheit wiegt ca. 360 kg (800 Pfund) und läuft frei auf den eingebauten Rollen, wenn die Ausrichtungskonsolen eingezogen sind. **ÄUSSERSTE VORSICHT WALTEN LASSEN**, wenn die RSS-48b die Rampe hinaufgerollt wird. Wenn die RSS-48b unkontrolliert auf der Rampe zurückrollt, kann das zu ernsthafter Körperverletzung bzw. Geräteschaden führen. Die Verpackungsanleitungen in diesem Handbuch oder an der Seite der Kiste vor dem Verpacken der RSS-48b vollständig lesen.

### AVERTISSEMENT

Il faut au minimum 2 personnes pour emballer le RSS-48b. L'unité pèse environ 360 kg (800 lbs) et, quand le dispositif de mise à niveau est rétracté, roule librement sur ses roulettes incorporées. **EXERCER UNE EXTRÊME PRUDENCE** lorsque l'on fait rouler le RSS-48b sur la rampe de chargement. Si on laisse le RSS-48b redescendre la rampe sans le contrôler, on s'expose à des blessures et/ou à des dégâts matériels graves. Lire toutes les instructions d'emballage contenues dans le présent manuel ou figurant sur le côté de la caisse avant d'emballer le RSS-48b.

### CAUTION

Always push the RSS-48b using the lower corners of the cabinet. **NEVER** push on the center of any panel or permanent damage may result. Because the RSS-48b is top heavy, do not move by pushing on the upper portion of the unit.

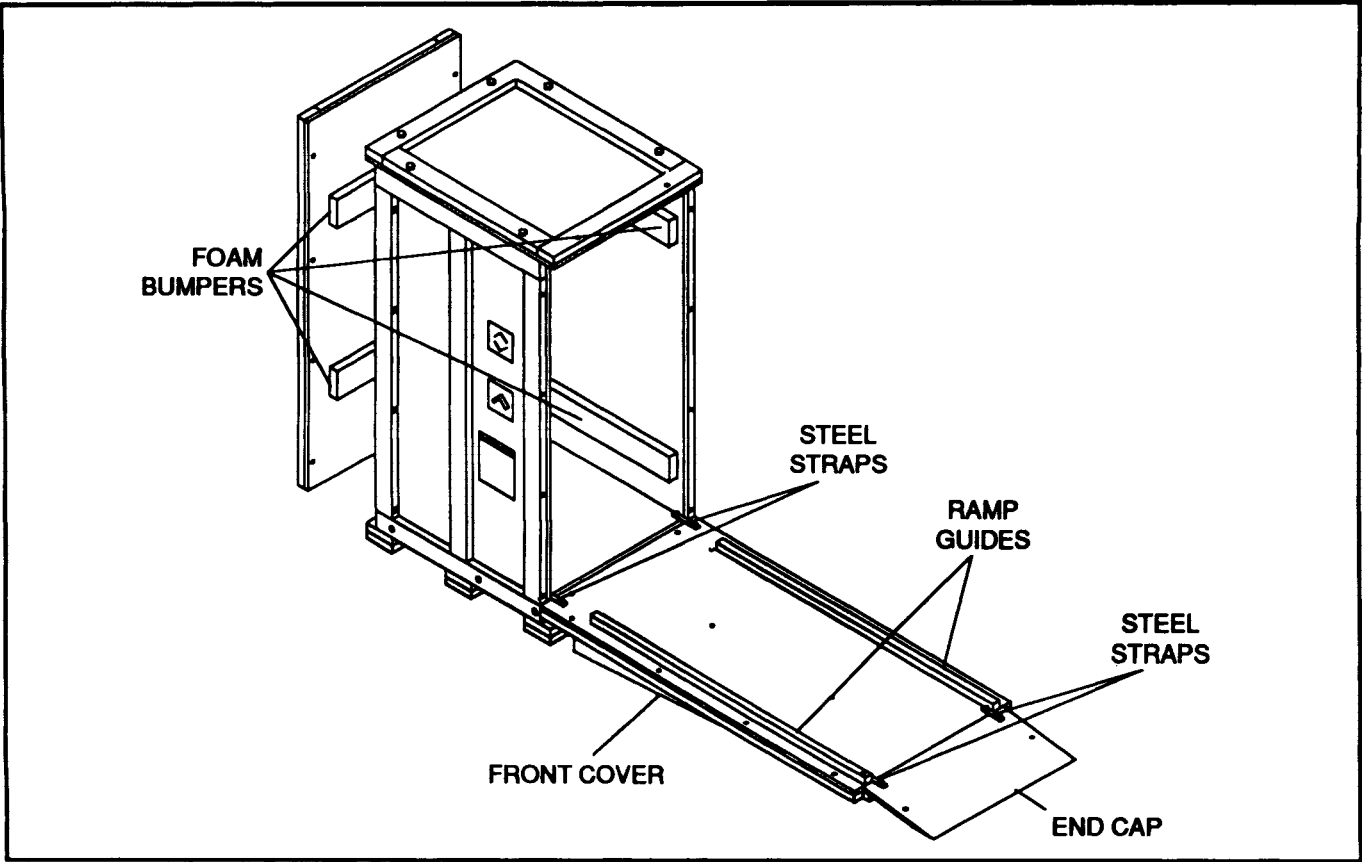

Figure 7-2. Shipping Crate

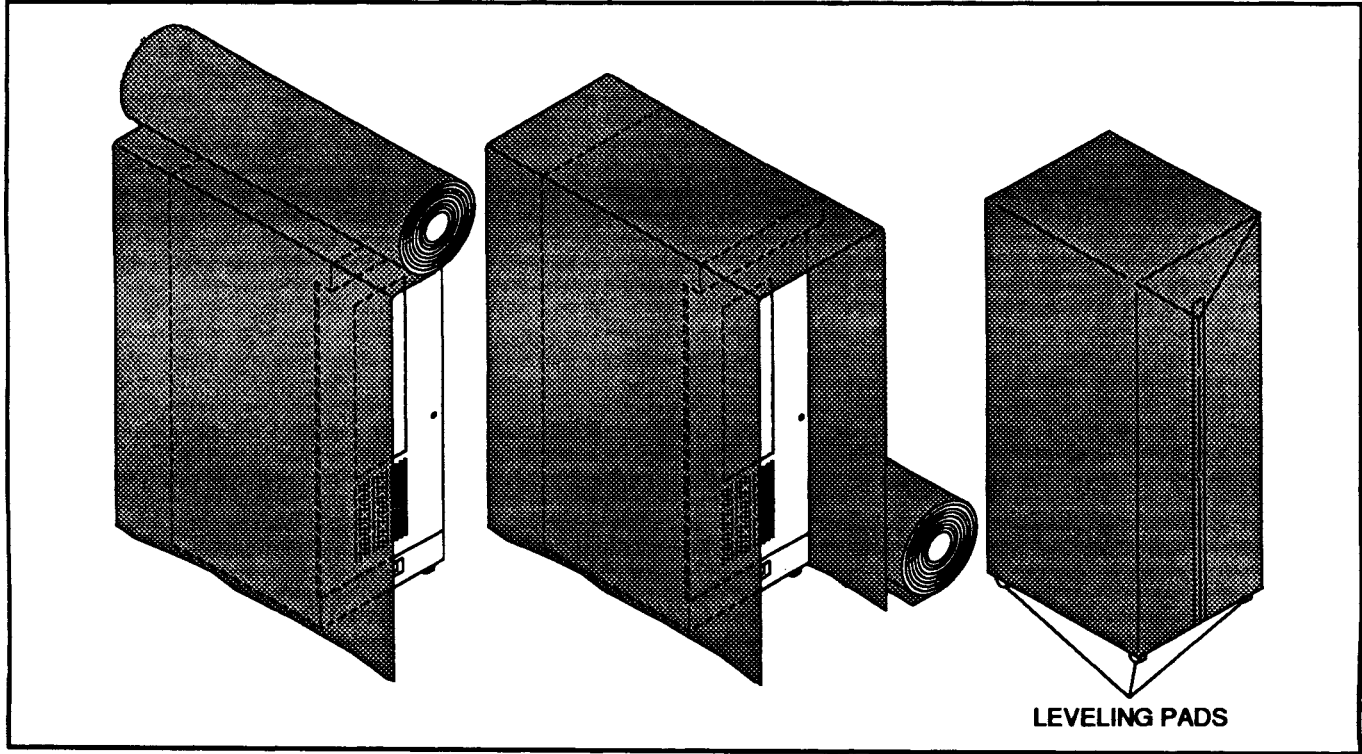

Figure 7-3. Wrapping the RSS-48b

1. Assemble the **ORIGINAL** shipping crate as shown with the front cover/ramp combination and end cap in front of the crate as shown in Figure 7-2.
- Secure top/bottom/side covers using 20  $\frac{3}{8}$  x  $6\frac{1}{4}$  bolts and washers.
- Secure cover/ramp combination and end cap using eight  $\frac{1}{4}$  x 2 screws and four steel straps provided.
- Leave the rear cover off.

**NOTE** If the **ORIGINAL** shipping crate is not available, contact your RSS-48b distributor for information on locating or fabricating a shipping container.

2. Apply 25G impact indicator to cabinet (if not already done), then wrap the RSS-48b using commercial grade 6' x  $\frac{1}{8}$ " cushioning material. Fold and tape using 2" mailing tape as shown in Figure 7-3.
3. Rotate all four leveling pads until fully retracted (up position).
4. Position the RSS-48b in front of the ramp with the rear of the RSS-48b towards the crate.

**WARNING**

A minimum of 2 persons are required to perform the next step. If the unit is allowed to roll back down the ramp uncontrolled, serious bodily injury and/or equipment damage may result.

**WARNUNG**

Mindestens 2 Personen sind zur Ausführung des nächsten Schrittes erforderlich. Wenn das Gerät unkontrolliert die Rampe hinunterrollt, kann das zu ernsthafter Körperverletzung bzw. Geräteschaden führen.

**AVERTISSEMENT**

Il faut au minimum 2 personnes pour déballer le RSS-48b. Si on laisse l'unité descendre la rampe sans la contrôler, on s'expose à des blessures et/ou à des dégâts matériels graves.

**CAUTION**

Always push the RSS-48b using the lower corners of the cabinet. NEVER push on the center of any panel or permanent damage may result. Because the RSS-48b is top heavy, do not move by pushing on the upper portion of the unit.

5. Push the RSS-48b up the ramp and inside the crate. When performing this step:
  - Remember to push on the corners of the cabinet, not on the center of any panel. Do not push on the front panel window or on the upper portion of the unit.
  - Slowly roll the unit up the ramp always keeping it between both ramp guides.
  - When placing in the crate, keep the front square with the crate opening so the sides of the unit do not bind with the foam bumpers inside of the crate.
  - The RSS-48b is completely inserted when 4" of space exists from the front of the unit to the end of the crate opening.
6. Once the unit is inside the crate, rotate the front and rear leveling pads until fully extended (down position).
7. Position the rear cover on the crate and secure using twelve  $\frac{3}{8}$  x  $6\frac{1}{4}$  bolts & washers.
8. Remove the eight  $\frac{1}{4}$  x 2 screws and four steel straps retaining the front cover/ramp combination and the end cap.
9. Place the end cap on the cover/ramp and secure using two  $\frac{1}{4}$  x 2 screws & washers.
10. Position the cover/ramp/end cap combination on the crate and secure using twelve  $\frac{3}{8}$  x  $6\frac{1}{4}$  bolts & washers.
11. Verify that the 50G impact and vertical tip indicators have not been triggered. See Section 6 for information on ordering new indicators if necessary.





# 8. DIAGRAMS

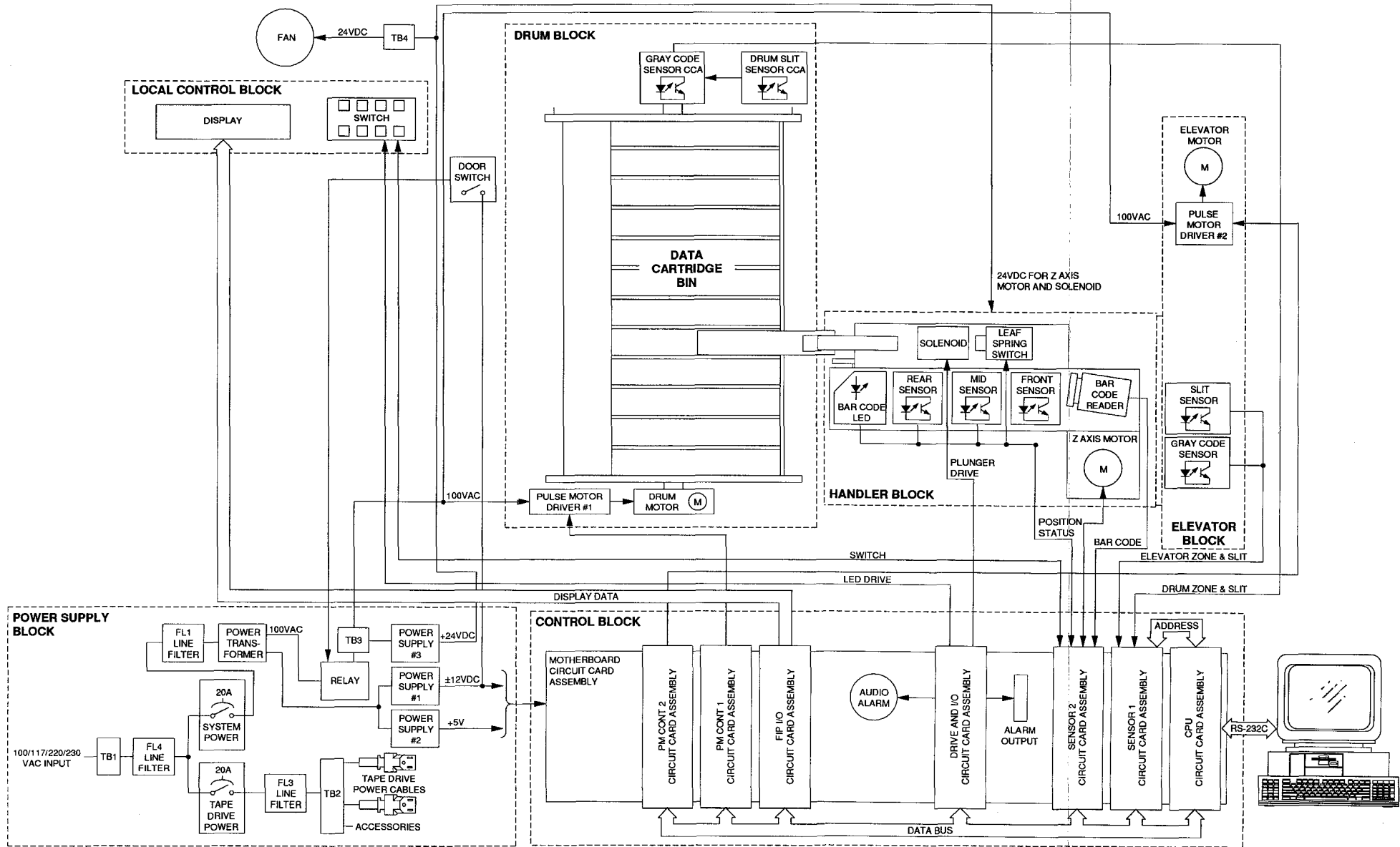

Figure 8-1. RSS-48b Functional Block Diagram

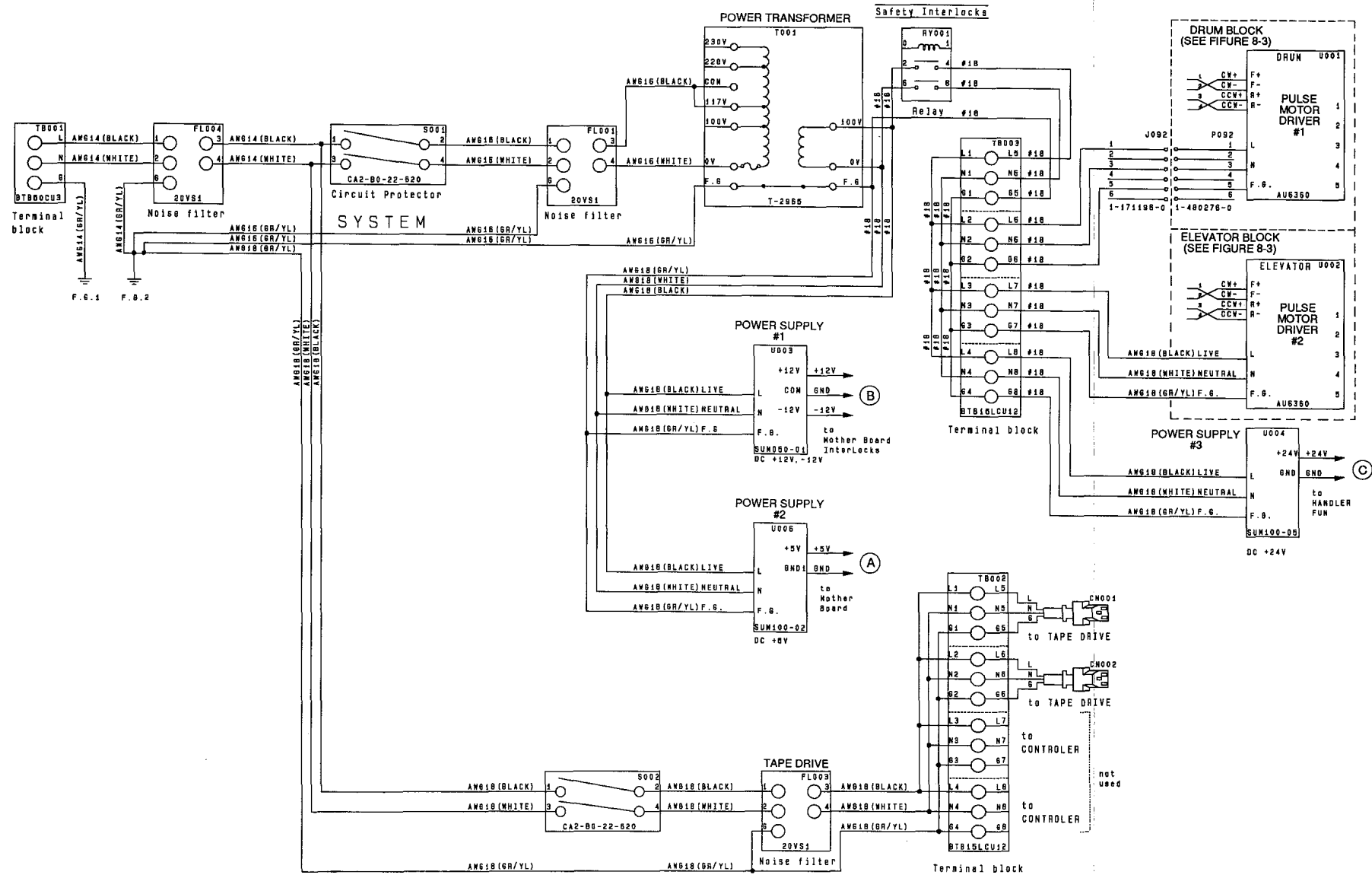

Figure 8-2. Power Interconnect Diagram (Sheet 1 of 2)

FIP  
DISPLAY  
(SEE FIGURE 8-3)

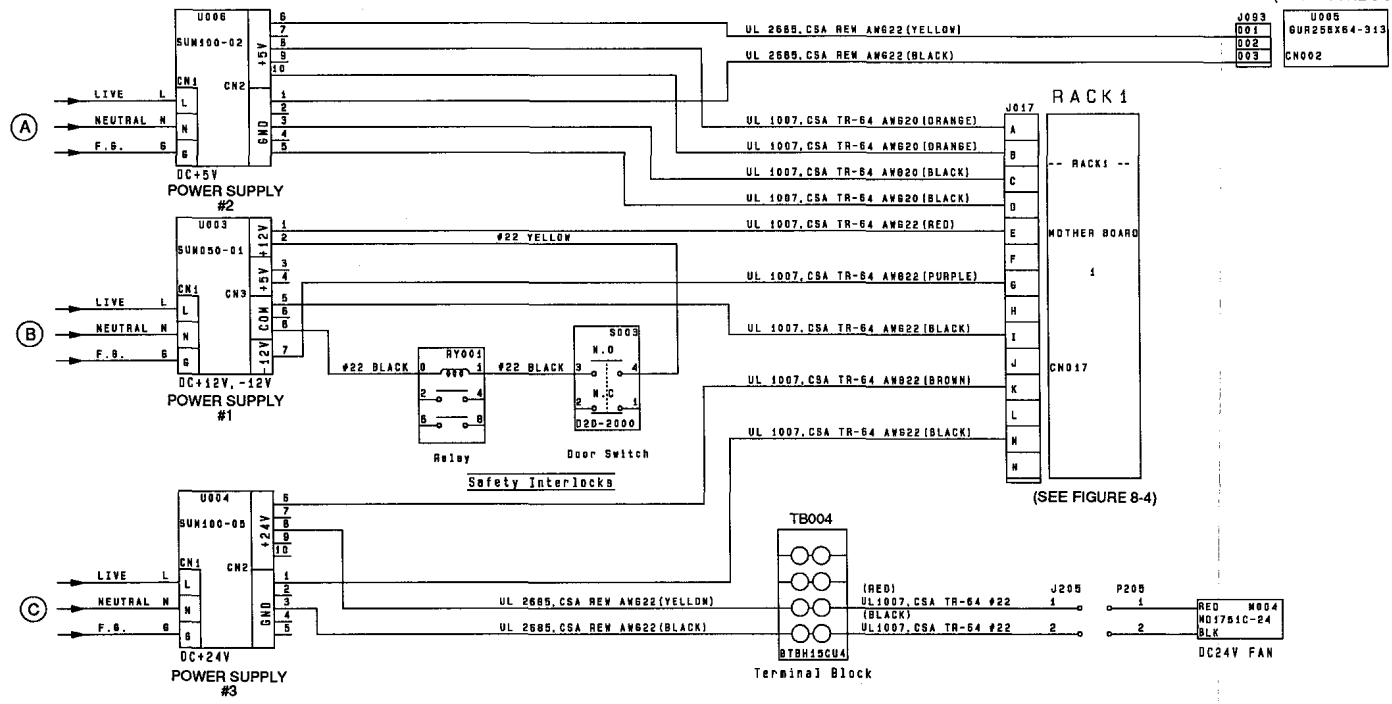

Figure 8-2. Power Interconnect Diagram (Sheet 2 of 2)

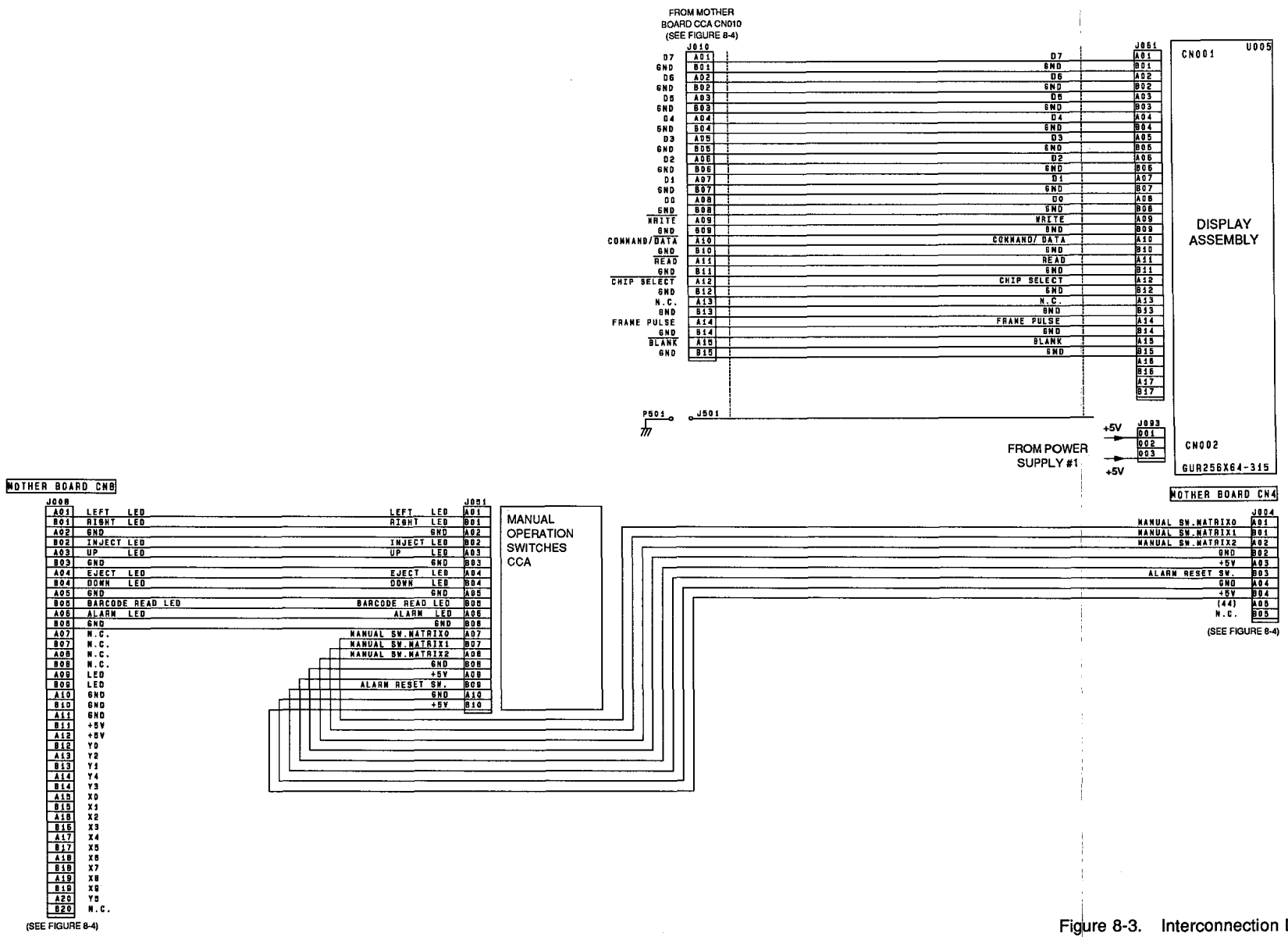
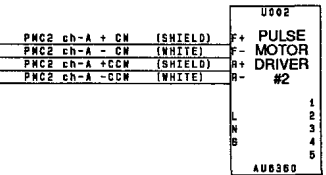
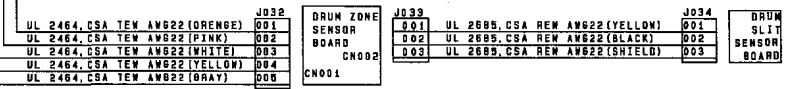
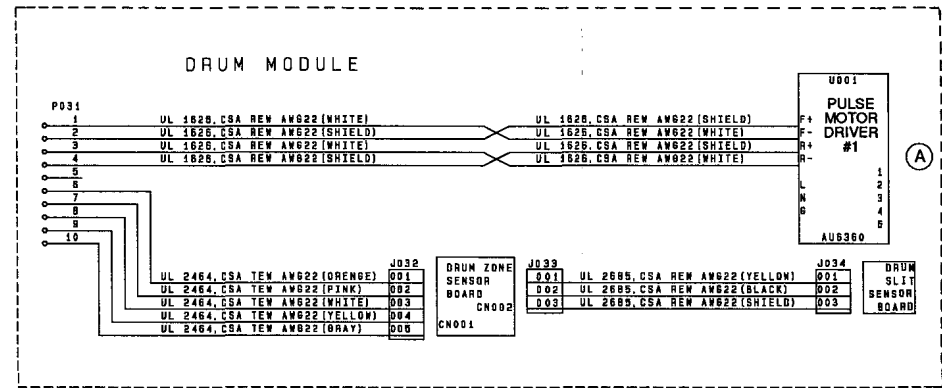
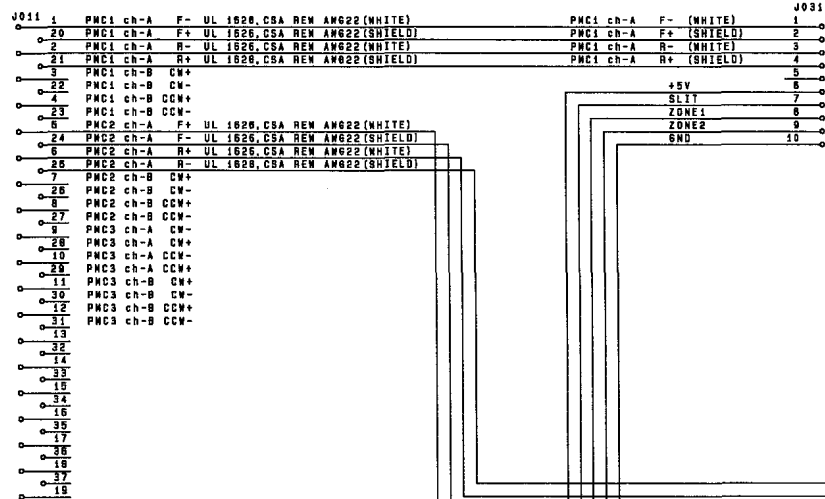

Figure 8-3. Interconnection Diagram (Sheet 1 of 4)

--- CONTROLLER ---

MOTHER BOARD CN11



MOTHER BOARD CN3

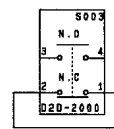
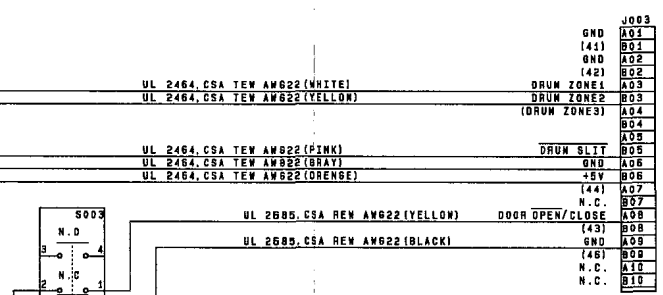

(SEE FIGURE 8-4)

Figure 8-3. Interconnection Diagram (Sheet 2 of 4)

DRUM MODULE

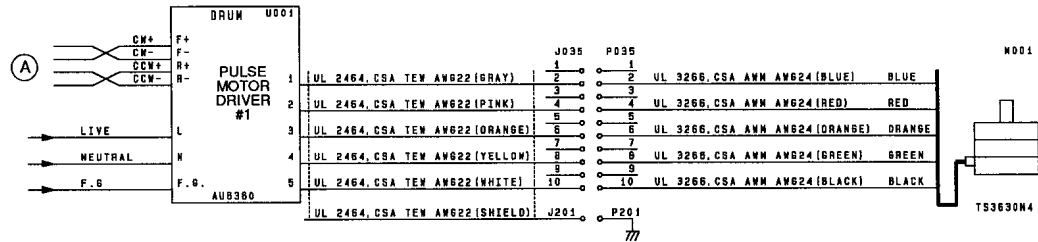

ELEVATOR MODULE

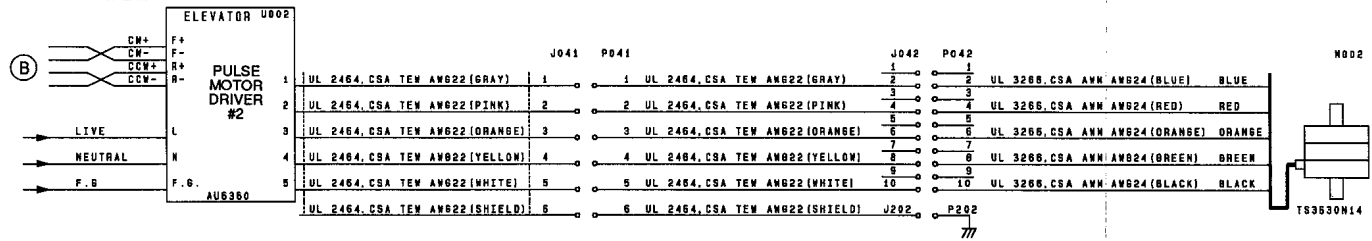

Figure 8-3. Interconnection Diagram (Sheet 3 of 4)

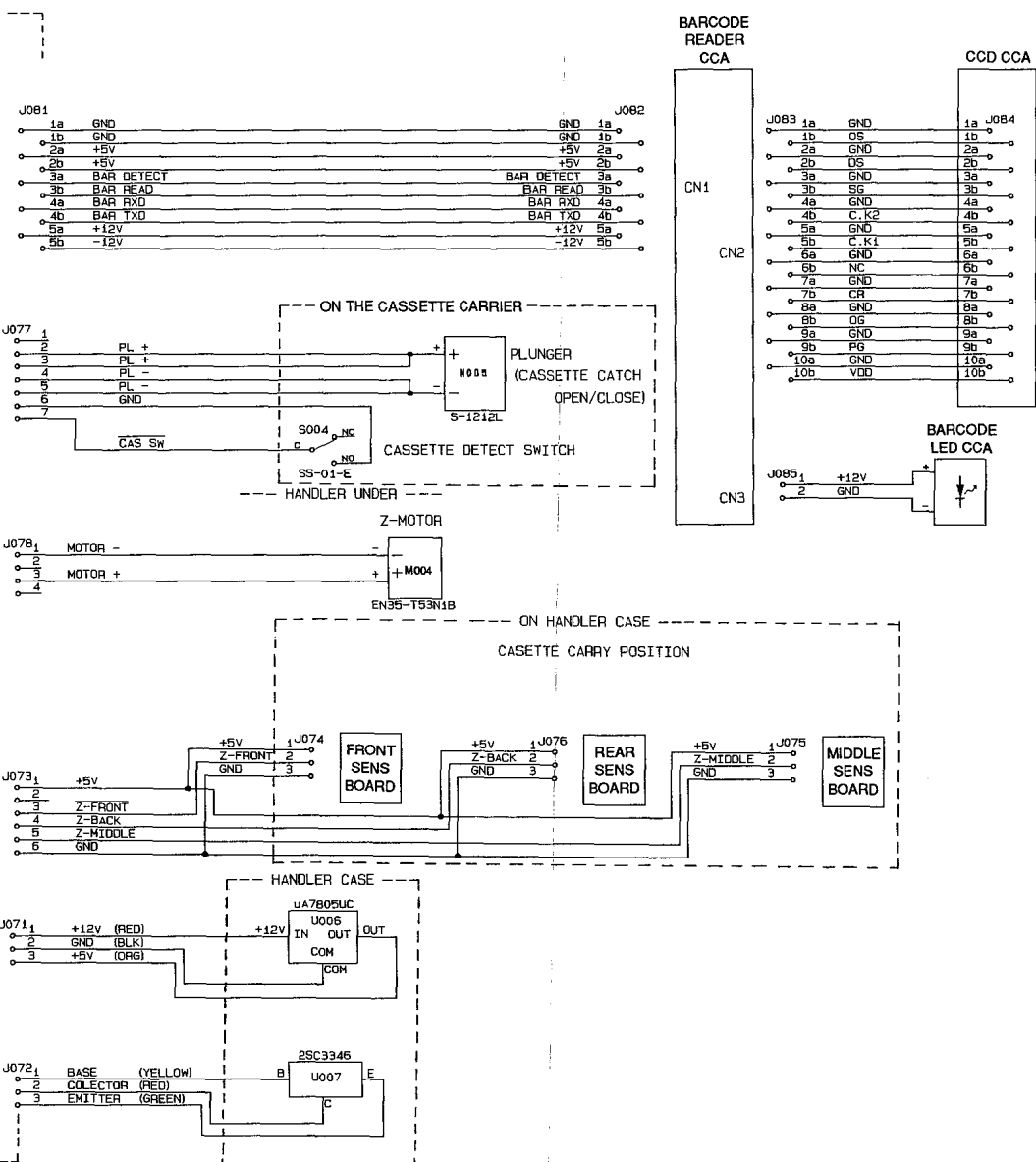
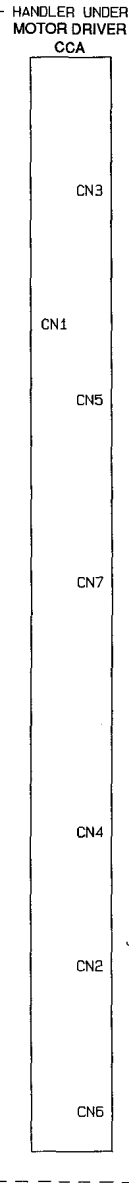
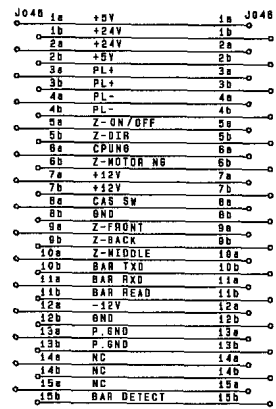
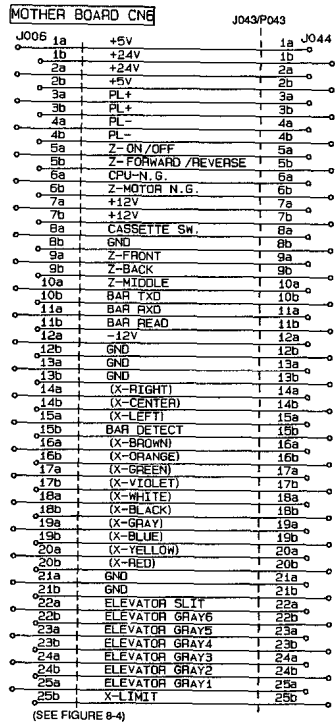

Figure 8-3. Interconnection Diagram (Sheet 4 of 4)



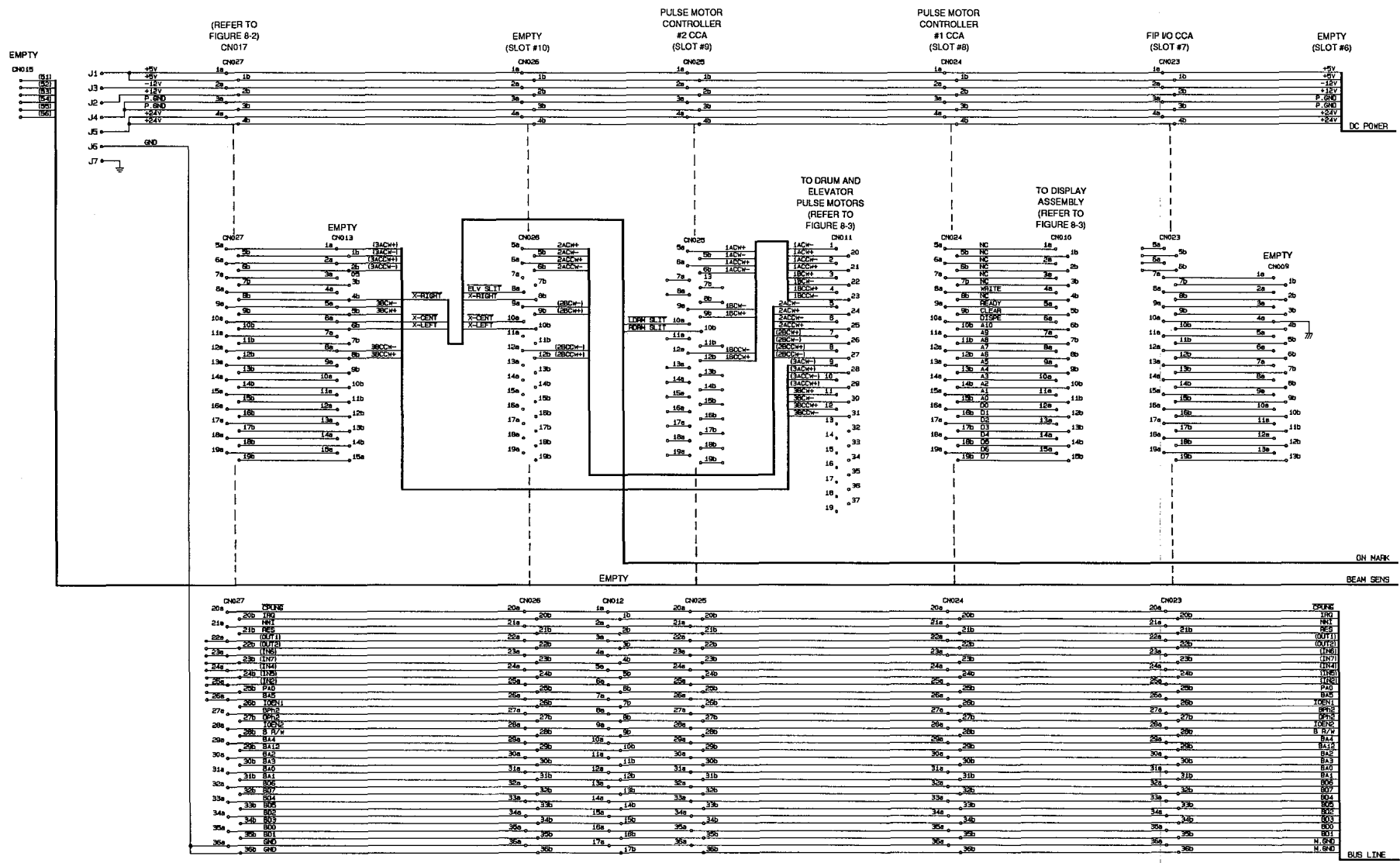

Figure 8-4. Motherboard CCA Interconnect Diagram (Sheet 2 of 2)



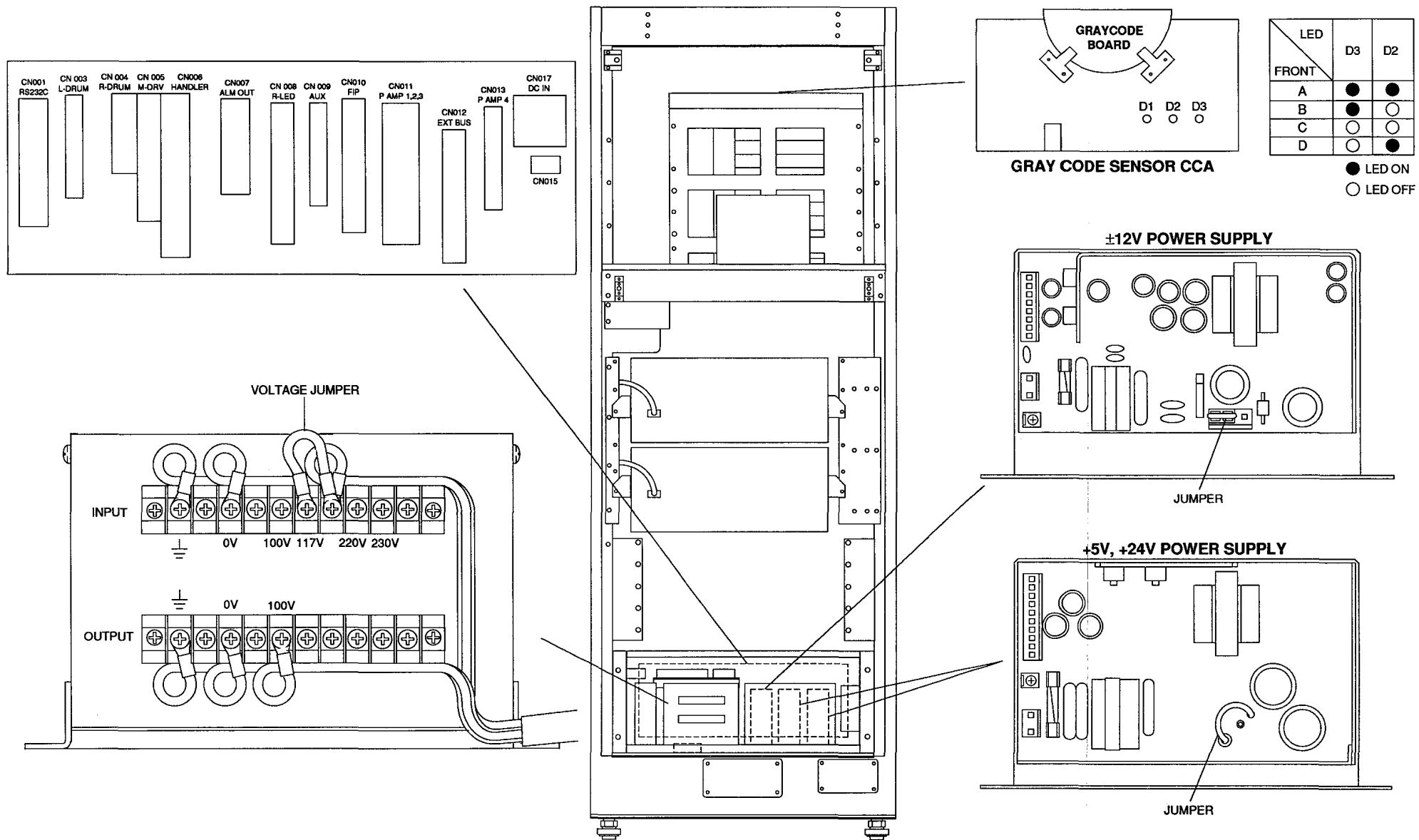

Figure 8-5. RSS-48b Led, Switch, and Jumpers Diagram (Sheet 2 of 2)

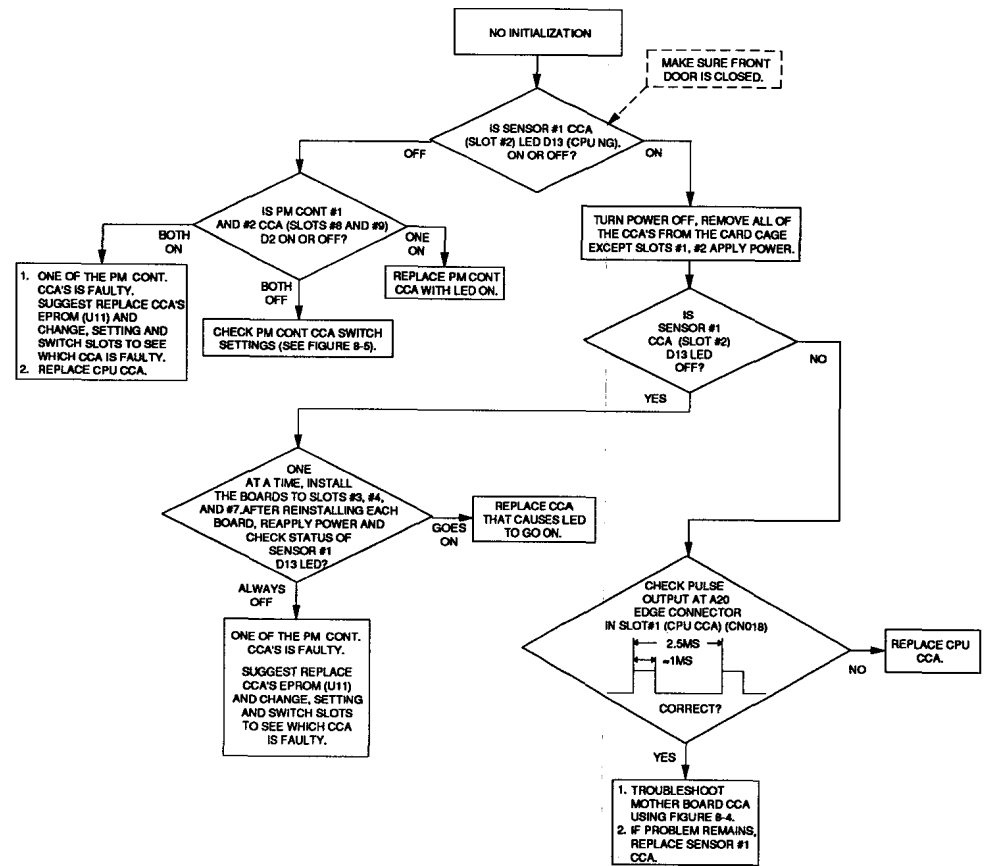
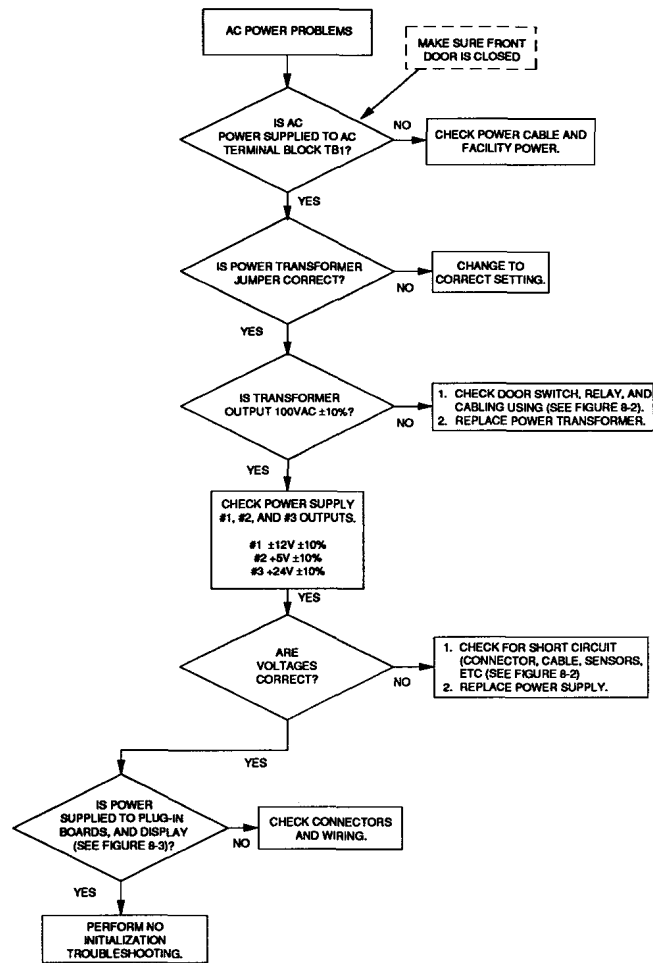
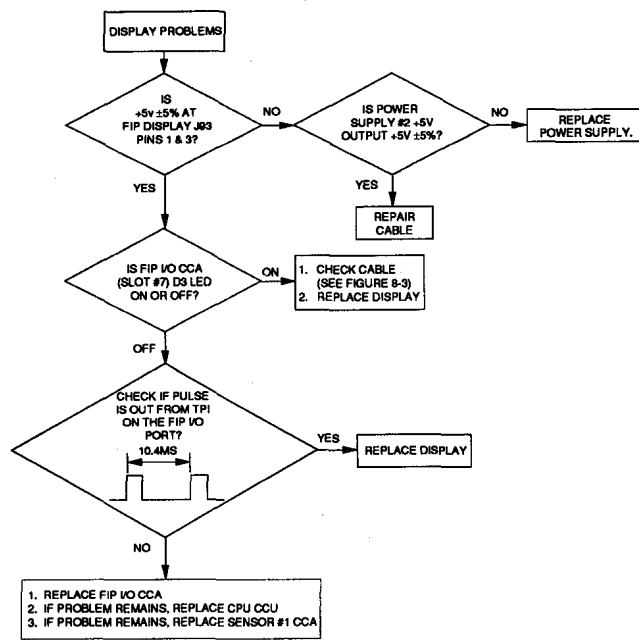

Figure 8-6. AC Power Problems and No Initialization Troubleshooting Tree



MANUAL PANEL SWITCH	SENSOR #2 CCA			
	D29	D30	D31	D32
NONE	×	○	○	○
LEFT	×	○	○	×
RIGHT	×	○	×	○
UP	×	○	×	×
DOWN	×	×	○	○
INJECT	×	×	○	×
EJECT	×	×	×	○
BAR CODE READ	×	×	×	×
ALARM RESET	○	○	○	○

× LED ON  
 ○ LED OFF

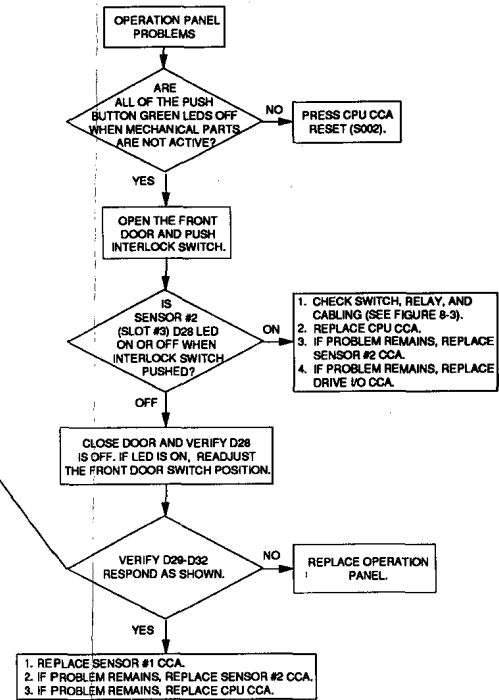

Figure 8-7. Display and Operational Panel Problems Troubleshooting Tree

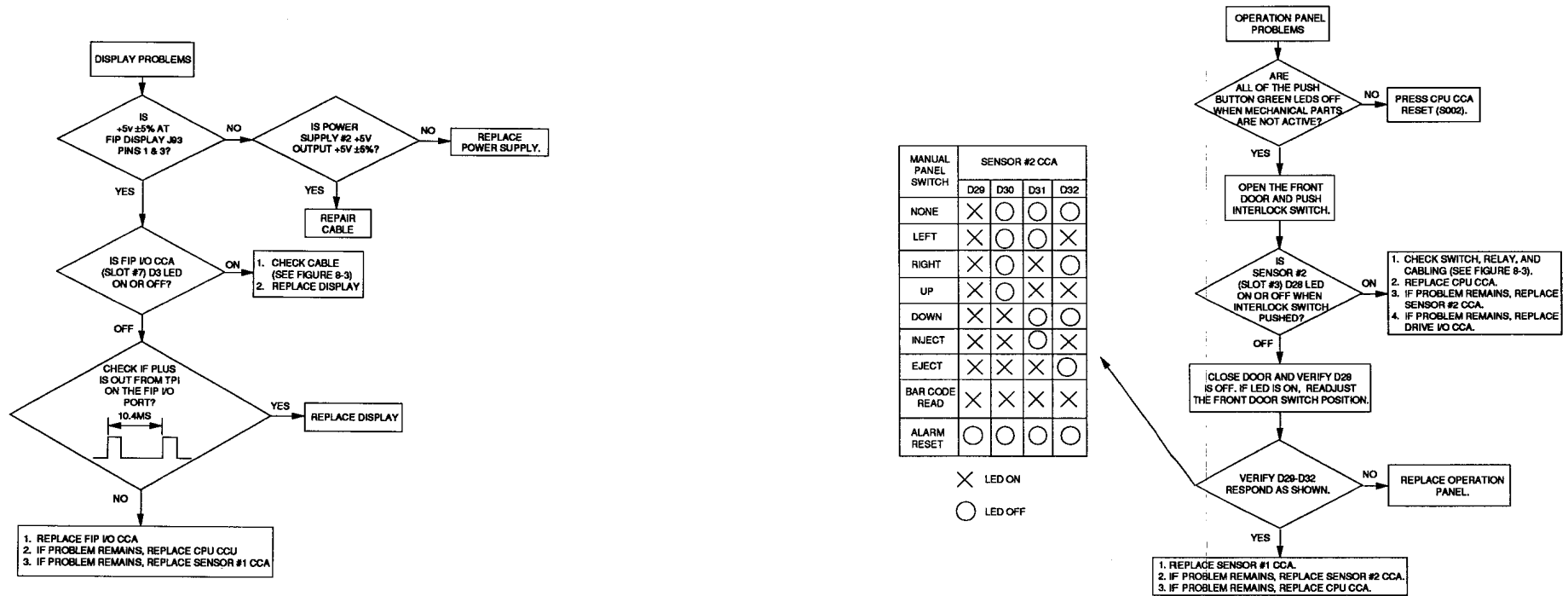

Figure 8-7. Display and Operational Panel Problems Troubleshooting Tree

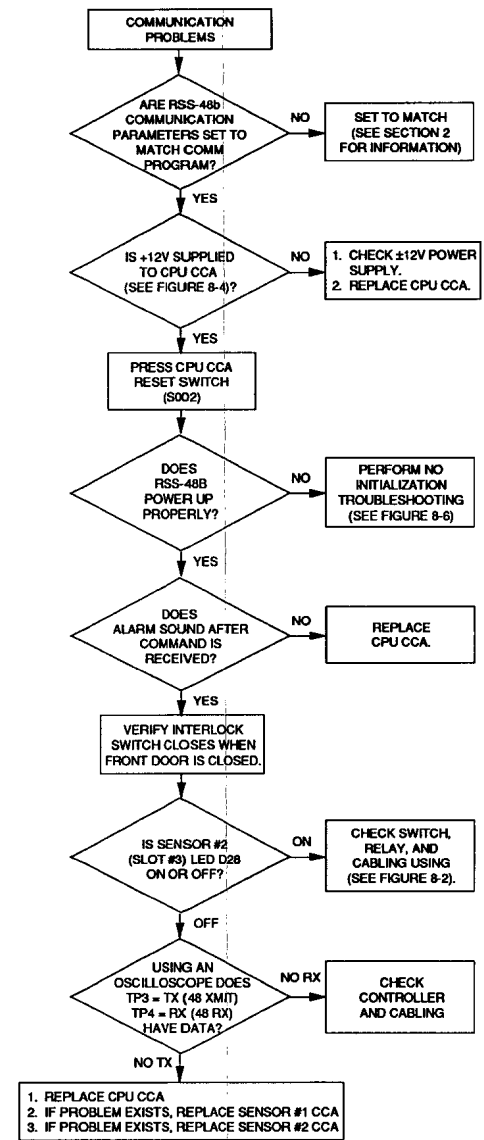

Figure 8-8. Communication Problems Troubleshooting Tree

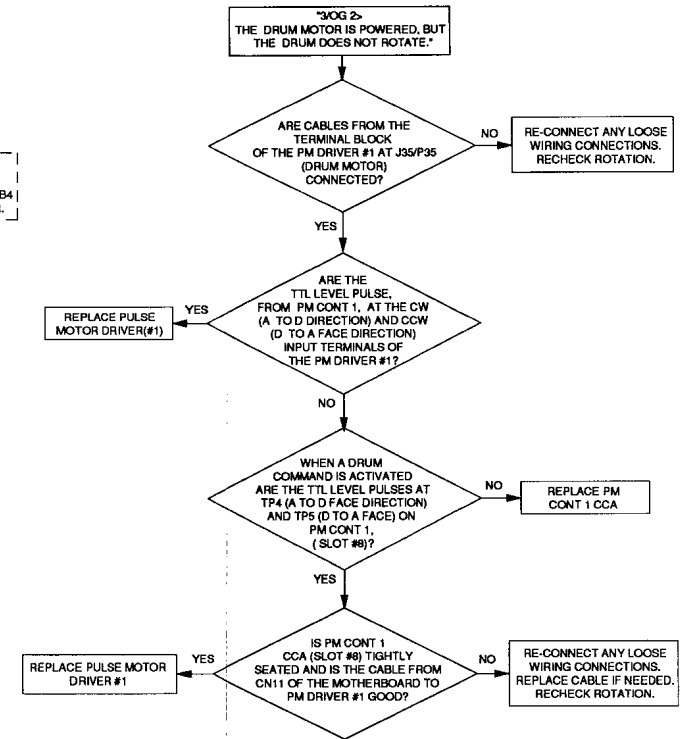
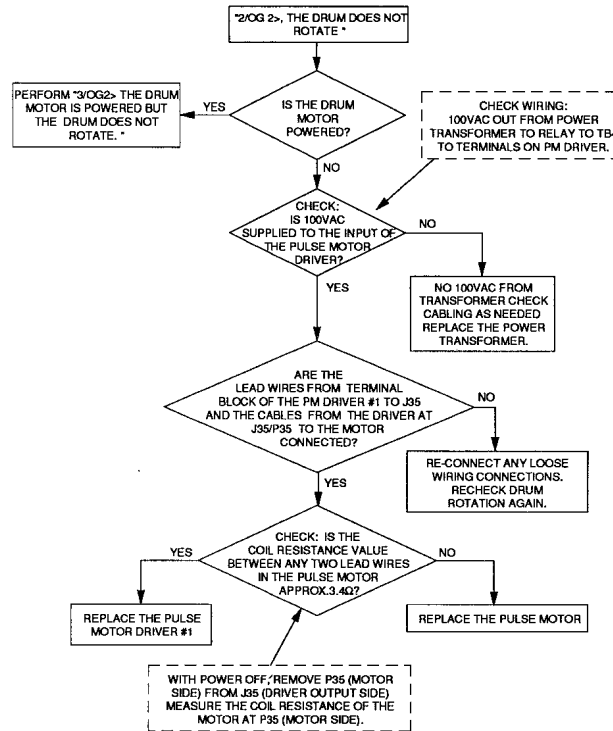
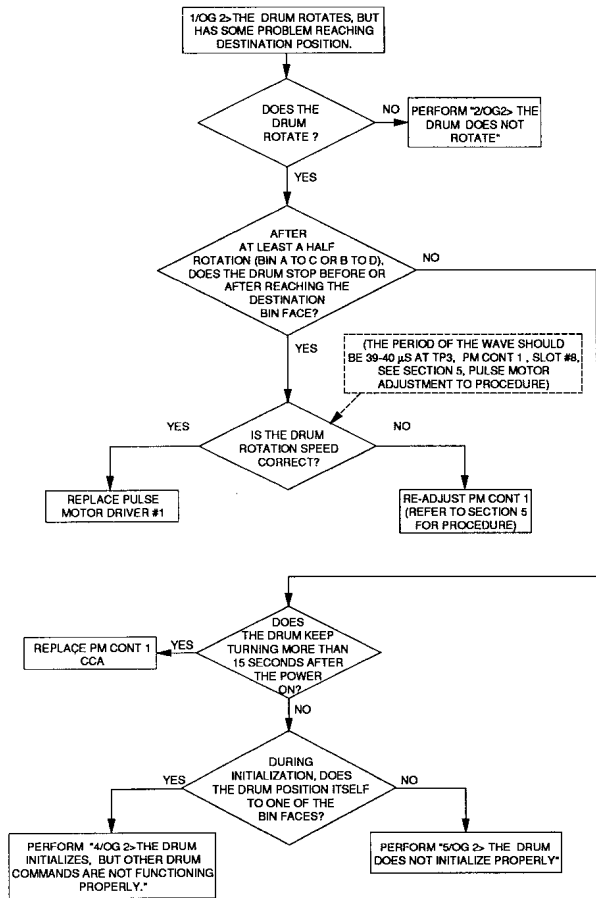

Figure 8-9. Error OG2> Troubleshooting Tree (Sheet 1 of 2)

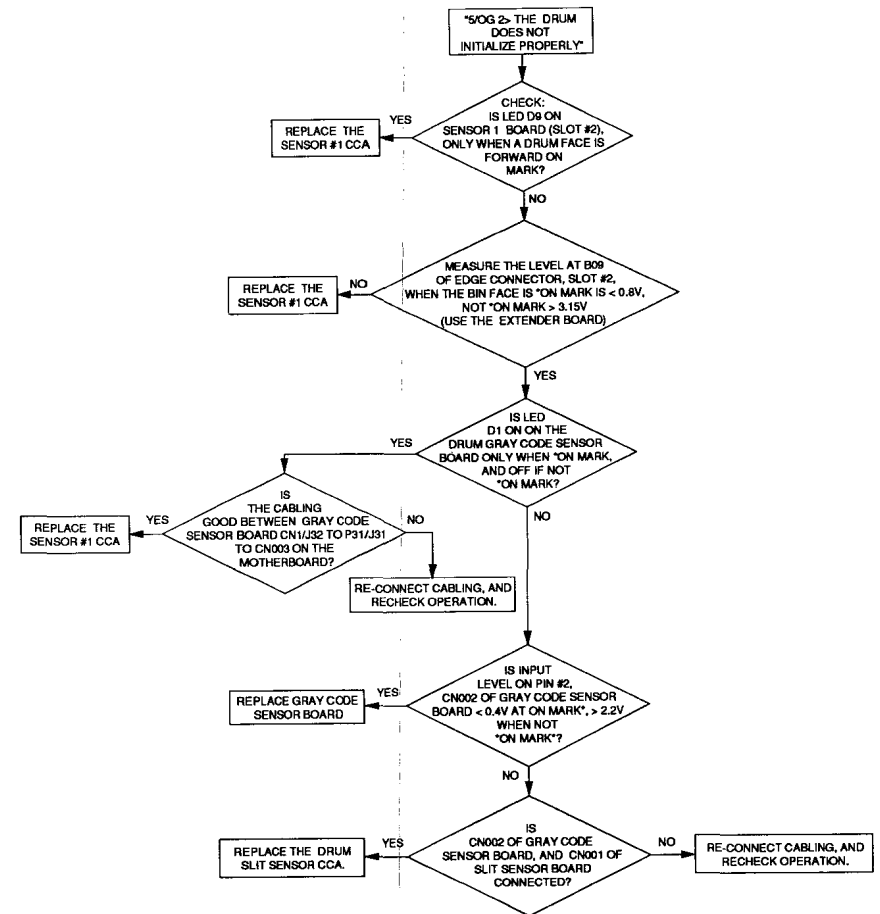
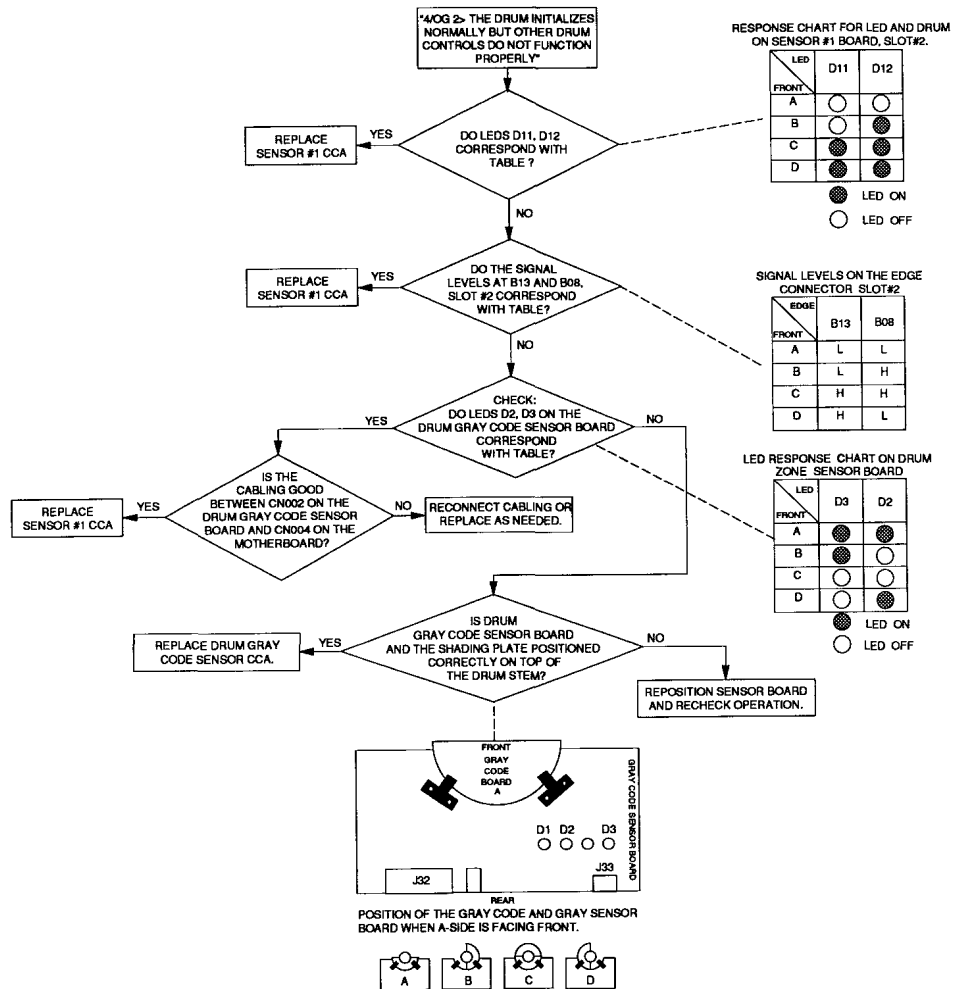

Figure 8-9. Error OG2> Troubleshooting Tree (Sheet 2 of 2)

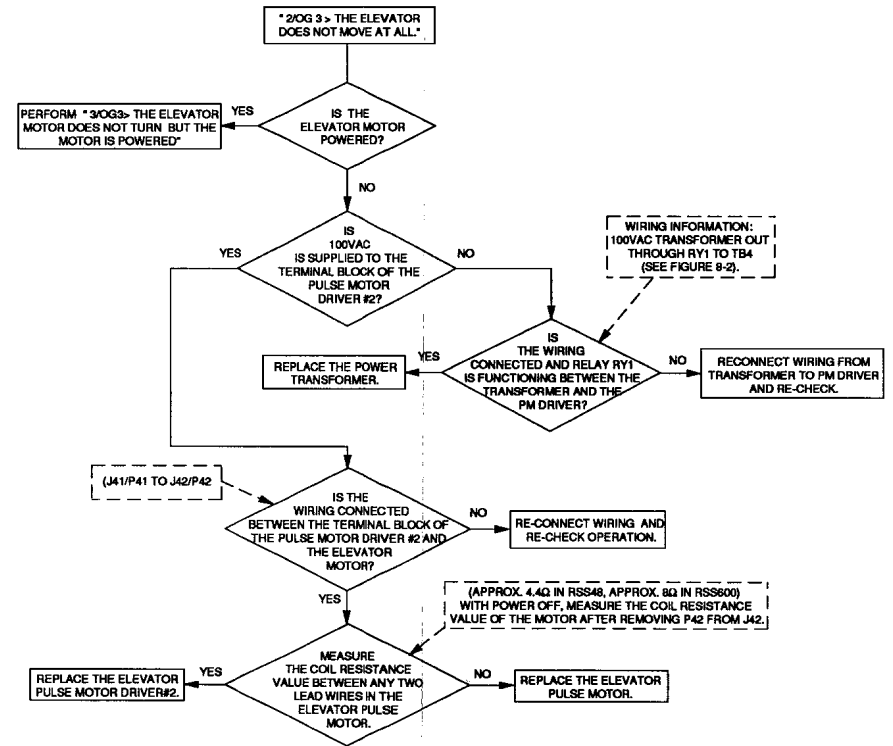
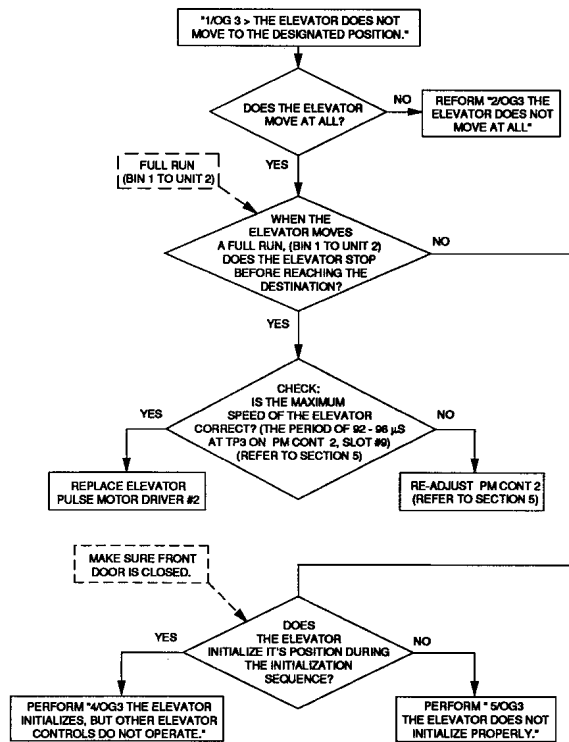
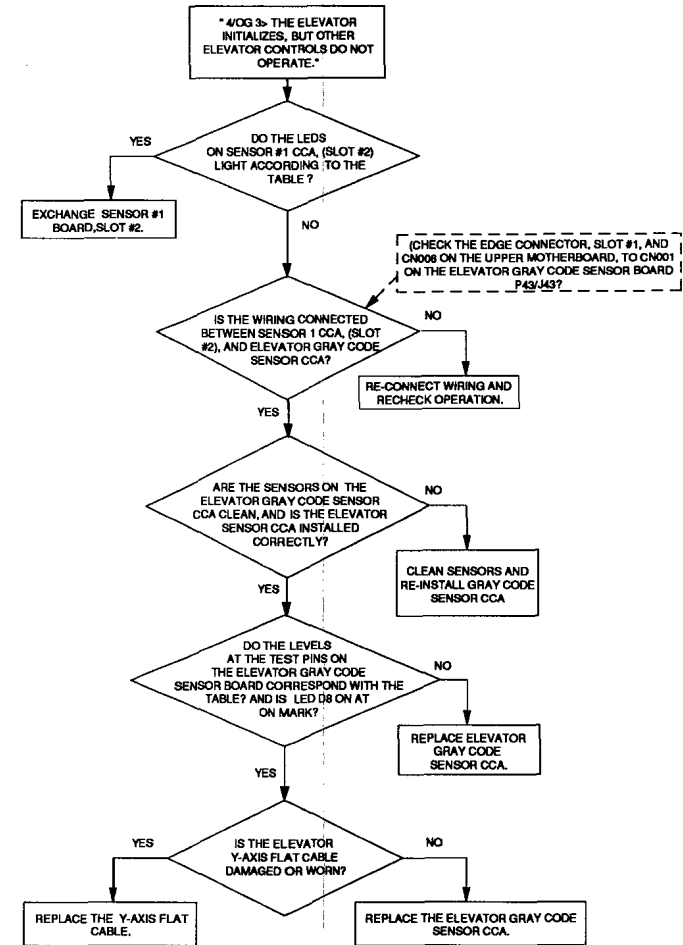
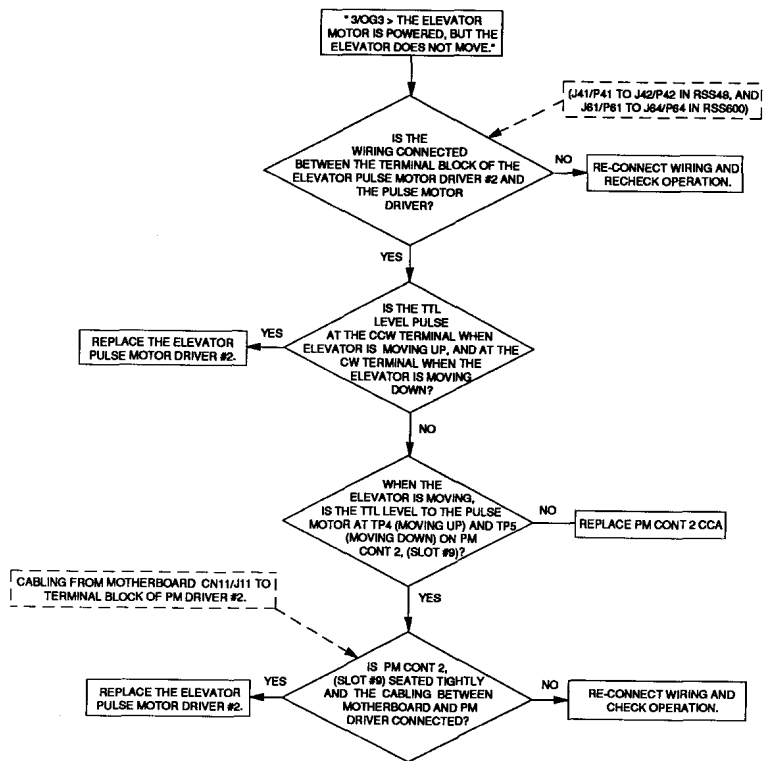

Figure 8-10. Error OG3> Troubleshooting Tree (Sheet 1 of 3)



\*ON MARK IS WHEN SENSOR IS ALIGNED WITH SLOT ON VERTICAL GUIDE.

Figure 8-10. Error OG3> Troubleshooting Tree (Sheet 2 of 3)

SENSOR 1 BOARD, SLOT #2  
LED D3 - D7 STATUS  
ELEVATOR GRAY CODE SENSOR BOARD  
TEST POINT LEVELS

ELEVATOR GRAY LED LEVEL	SENSOR #1 CCA SLOT #2				
	D7 TP2	D6 TP3	D5 TP4	D4 TP5	D3 TP6
1	○	○	○	○	●
2	○	○	○	●	●
3	○	○	○	○	○
4	○	○	●	●	○
5	○	○	●	●	●
6	○	○	○	○	●
7	○	○	●	○	○
8	○	●	●	○	○
9	○	●	●	○	○
10	○	●	●	○	●
11	○	●	●	●	●
12	○	●	●	●	○
TAPE DRIVE 1 (20)	●	●	○	●	○
TAPE DRIVE 2 (26)	●	○	●	○	●

SENSOR #1 CCA SLOT #2      ELEVATOR GRAY CODE SENSOR CCA  
 ○ :LED Goes out      ○ :HIGH VOLTAGE LEVEL  
 ● :LED Lights      ● :LOW VOLTAGE LEVEL

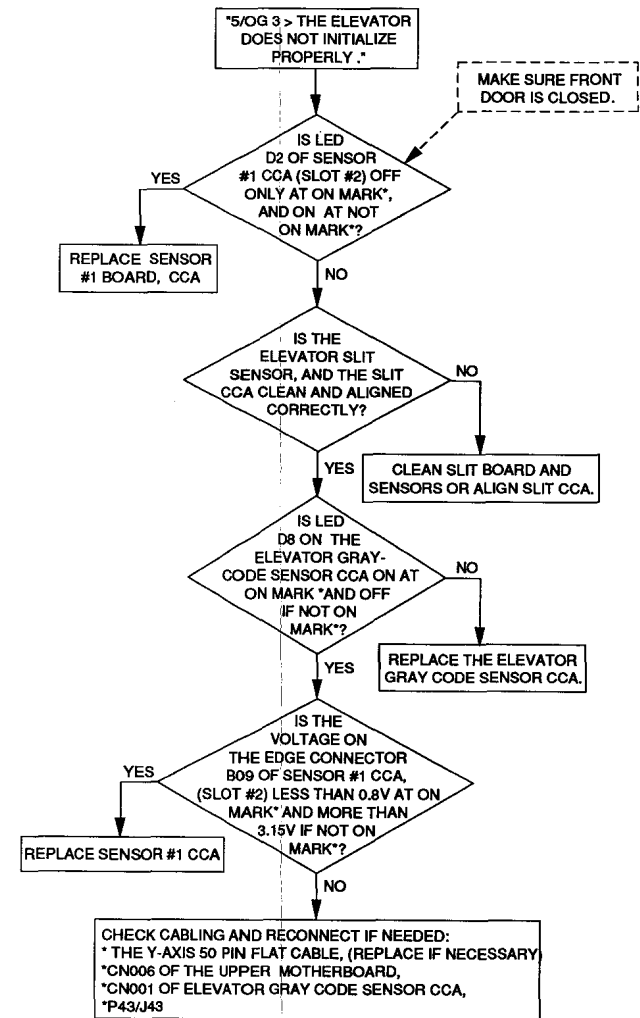

\*ON MARK IS WHEN SENSOR IS ALIGNED WITH SLOT ON VERTICAL GUIDE.

Figure 8-10. Error OG3> Troubleshooting Tree (Sheet 3 of 3)

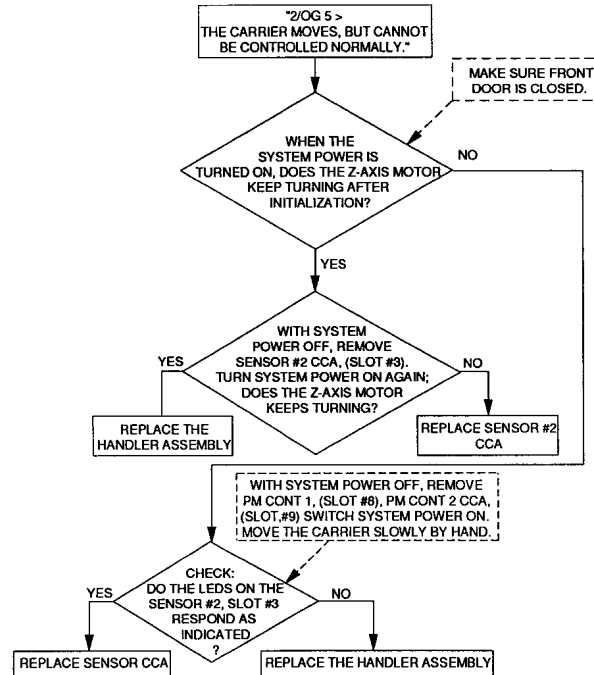
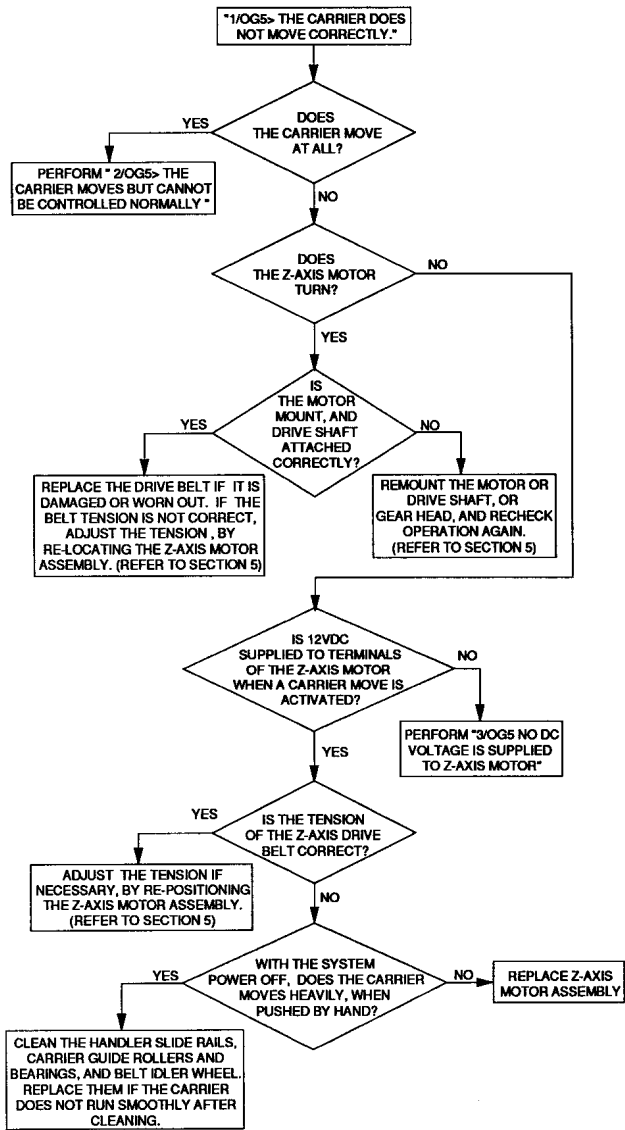

LED RESPONSE CHART  
SLOT#3 SENSOR 2 BOARD

POSITION	Z-	Z-	Z-		
LED					
D22	●	○	○	○	○
D23	○	●	○	○	○
D24	○	○	●	○	○

● LED ON  
○ LED OFF

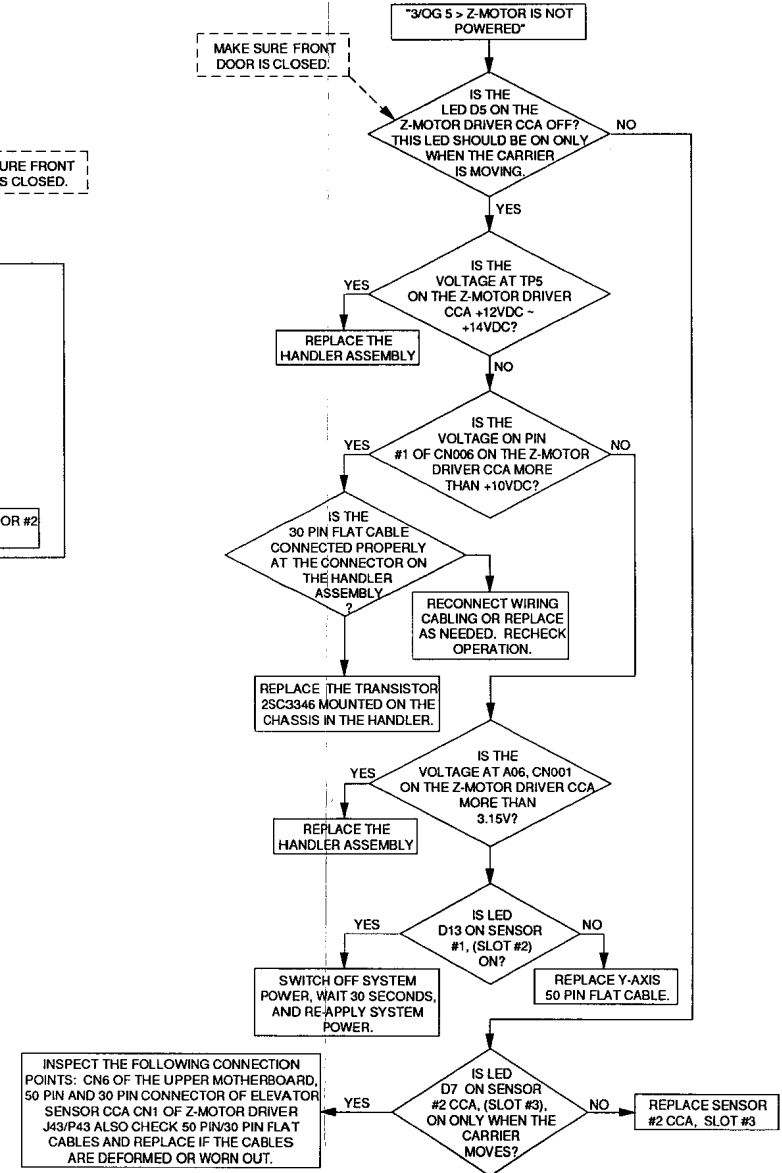

Figure 8-11. Error OG5> Troubleshooting Tree

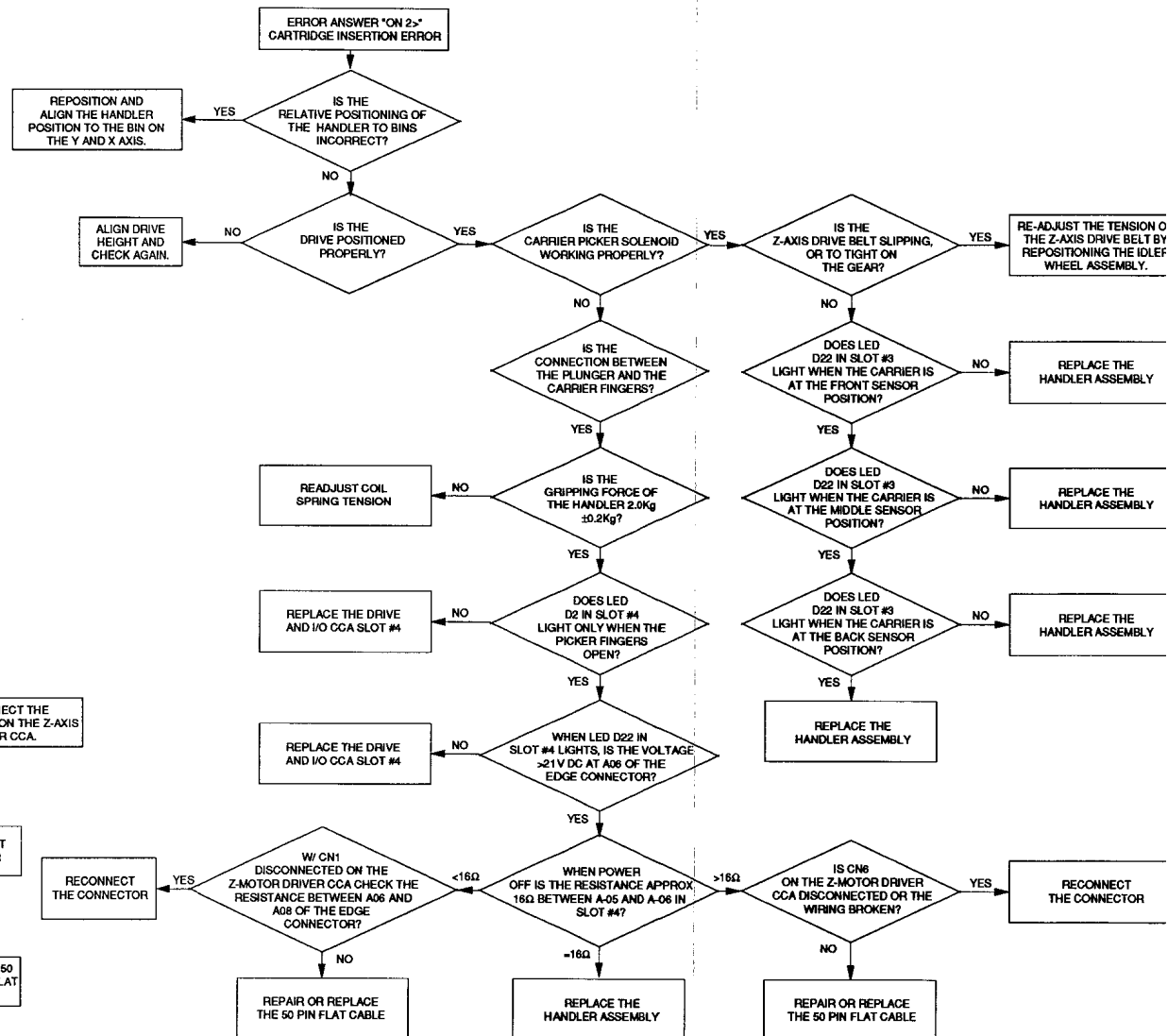
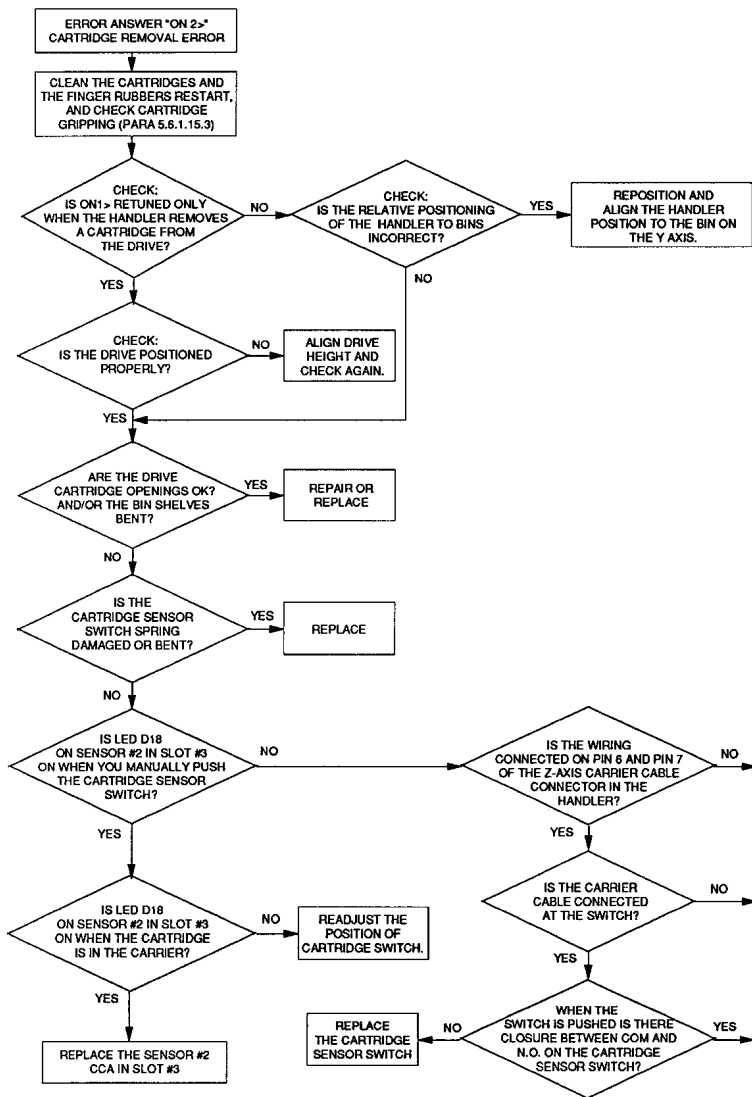

Figure 8-12. Error ON1> and ON2> Troubleshooting Tree

# M E T R U M

INFORMATION STORAGE

## TECHNICAL PUBLICATIONS

---

**YOUR COMMENTS ARE REQUESTED . . .**

**as a part of our continuing effort to provide you with better services, we would like to receive any comments you may have on this technical manual.**

---

**Errors Noted (List Page, Paragraph, or Figure Number):**

DETACH HERE

**Other Suggestions for Improvement:**

**FROM:**

**DATE:**

**NAME** \_\_\_\_\_

**COMPANY** \_\_\_\_\_

**TITLE** \_\_\_\_\_

**ADDRESS** \_\_\_\_\_

**TECHNICAL MANUAL**

**RSS-48b**

**AUTOMATED TAPE LIBRARY**

**16828600-001B - AUGUST 1993**



**NO POSTAGE  
NECESSARY  
IF MAILED  
IN THE  
UNITED STATES**

**BUSINESS REPLY MAIL**  
FIRST CLASS      PERMIT NO. 2259      Denver, Colorado

**POSTAGE WILL BE PAID BY**

**M E T R U M**  
INFORMATION STORAGE  
**P.O. BOX 5227**  
**DENVER, COLORADO 80217**

**ATTENTION: SUPERVISOR TECHNICAL PUBLICATIONS, MS 2000**

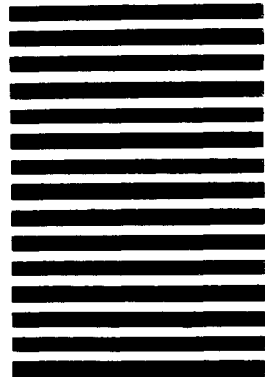

**DETACH HERE**

**M E T R U M**  
INFORMATION STORAGE